

Amity

TECHNOLOGY

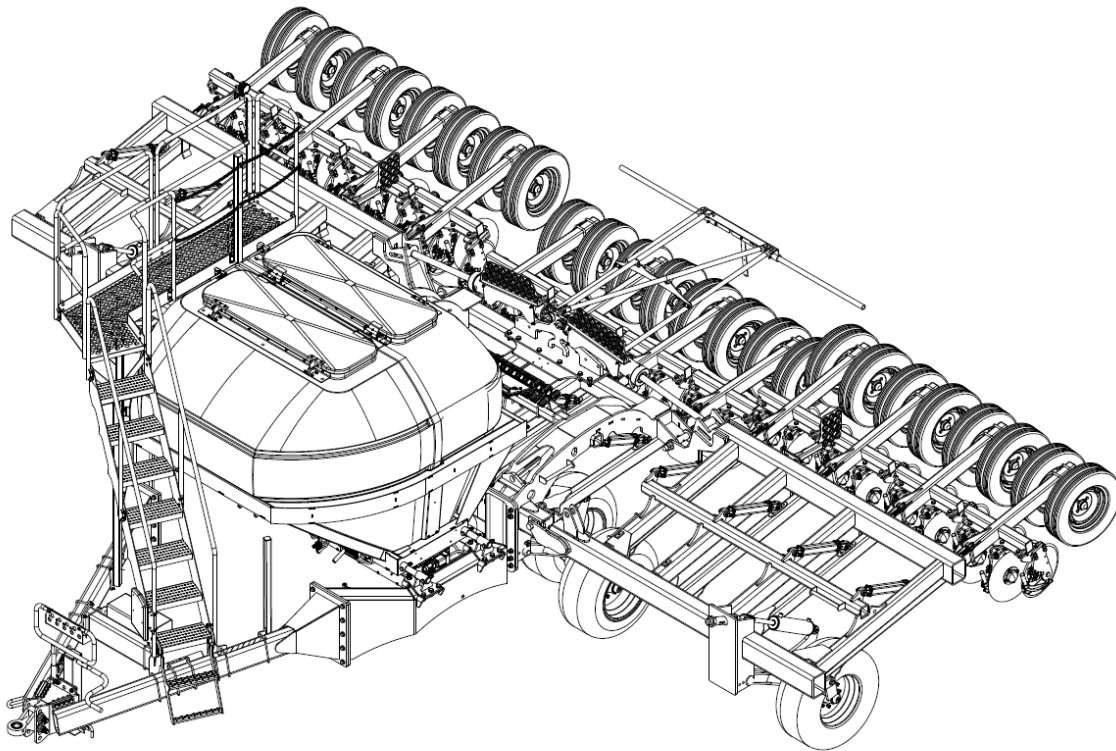

OPERATING MANUAL



Narrow Transport

Single Disc Drill

Amity Technology, LLC
2800 7th Avenue North
Fargo, ND 58102
(701) 232-4199
www.amitytech.com

P/N 322042B

AMITY TECHNOLOGY, LLC LIMITED WARRANTY FOR NEW PRODUCTS

- 1. General Provisions.** This Warranty shall apply to the original purchaser of (1) any new and unused machine manufactured by Amity Technology, LLC (“Amity”), and (2) any new and unused part which is manufactured by Amity for use in an Amity machine, jointly referred to as “Products,” whether such Product is purchased through a dealer or directly from Amity. Under this Warranty, Amity will repair or replace, as it chooses in its sole discretion, any covered Product, or any component thereof, which Amity determines to be defective. This Warranty shall be in effect for a period of twelve (12) months (“the Warranty Period”), beginning on the date of delivery of the covered machine or part by the dealer or Amity to the purchaser (“the Warranty Start Date”). The purchaser must pay the cost of transportation of a Product to be repaired or replaced to and from an authorized Amity dealer. This Warranty may not be transferred from the original purchaser of a Product to any other person. This Warranty does not give a purchaser the right to any relief other than repair or replacement of the Product, and it specifically does not allow for consequential or incidental damages, exemplary or punitive damages, or costs and fees.
- 2. Scope and Limitations of Warranty.** With respect to machines, this Warranty is void if any part not supplied by Amity is used in assembly or repair of the machine, or if the machine has been altered, abused or neglected, as determined by Amity. With respect to parts, this Warranty is void if the part is used in any manner other than that for which it is intended. This Warranty does not extend in any way to tires and any other component of a Product warranted by another manufacturer, a copy of which warranty is provided herewith (“Third-Party Warranties”). In the event Amity determines that a Product is not defective, or that any other provision of this Paragraph 2 operates to limit the Warranty, this Warranty shall not apply and the purchaser shall be responsible for transporting the Product from the authorized Amity dealer’s location within 10 days of notice by Amity.
- 3. Procedures for Obtaining Service.** To secure Warranty service, a purchaser must (1) report the defect to an authorized dealer and request repair within 45 days of the failure and within the Warranty Period; (2) present evidence that this Warranty applies to the Product; (3) present evidence of the Warranty Start Date; and (4) bring the Product to an authorized Amity dealer within a reasonable period of time after reporting the defect.
- 4. LIMITATION OF IMPLIED WARRANTIES AND OTHER REMEDIES.** To the extent allowed by law, neither Amity, its dealers, nor any company affiliated with Amity makes any warranties, representations, or promises as to the quality, performance, or freedom from defect of any Product covered by this Warranty.

AMITY HEREBY WAIVES, TO THE EXTENT APPLICABLE, ANY AND ALL IMPLIED WARRANTIES OF MERCHANTABILITY AND FITNESS FOR A PARTICULAR PURPOSE. A PURCHASER’S ONLY REMEDIES IN CONNECTION WITH THIS WARRANTY ARE THOSE SET FORTH ON THIS PAGE. IN NO EVENT WILL AMITY, ITS DEALERS, OR ANY COMPANY AFFILIATED WITH AMITY BE LIABLE FOR INCIDENTAL, CONSEQUENTIAL OR PUNITIVE DAMAGES.

Some states do not allow waivers of certain warranties, so the above waivers may not apply to you. You may also have other rights which vary from state to state.

- 5. No Dealer Warranty.** This is the exclusive warranty applicable to Amity Products. No dealer has any authority to make any other warranty, modify, limit, or expand the terms of this Warranty in any fashion, or make any representation or promise on behalf of Amity.
- 6. Dispute Resolution.** Any controversy or claim arising out of or relating to this Warranty must be settled by arbitration in Fargo, North Dakota, at a time and location designated by the arbitrator, but not exceeding 30 days after a demand for arbitration has been made, and may be conducted by electronic, video, or other technical means. Arbitration will be conducted by the American Arbitration Association in accordance with its Rules of Commercial Arbitration, and judgment upon the award rendered by the arbitrator may be entered in any court having jurisdiction thereof. The arbitrator will have the authority to order Amity to undertake a repair or replace any Product, at its election, if the arbitrator finds that this Warranty requires Amity to do so. The arbitrator will not have the authority to impose any other remedy against Amity, including without limitation consequential or incidental damages, exemplary or punitive damages, or costs and fees.

Narrow-Transport Single Disc Drill

1 Safety	7
1.1 Introduction	9
1.1.1 Safety alert symbol	9
1.1.2 Safety messages	9
1.1.3 Informational messages	9
1.1.4 Safety signs	9
1.1.5 A word to the operator	10
1.1.6 This manual	11
1.2 Operation	12
1.2.1 Prepare for operation	12
1.2.2 General information	12
1.2.3 Personal protective equipment	13
1.2.4 Seat instructions	13
1.2.5 Shield and guards	14
1.2.6 Exhaust warning	14
1.2.7 Flying debris	15
1.2.8 Agricultural chemicals	15
1.3 Travel on public roads	16
1.4 Maintenance	18
1.4.1 General maintenance information	18
1.4.2 Fire prevention and first aid	19
1.4.3 High pressure leaks	20
1.4.4 Tire safety	21
1.4.5 Replacement parts	21
1.5 Wing lock pins	22
1.5.1 Installing the wing lock pins	22
1.5.2 Removing the wing lock pins	23
1.6 Toolbar locks	24
1.6.1 Locking the toolbar locks	24
1.6.2 Unlocking the toolbar locks	25
1.7 Hydraulic lock-out valves	27
1.8 Marker lamps	28
1.9 Safety and informational signs	29
1.9.1 Safety sign overview	29
1.9.2 Maximum speed sign	30
1.9.3 General safety alert hazard	30
1.9.4 General safety alert hazard	30
1.9.5 Negative tongue weight hazard	30
1.9.6 Hydraulic fluid injection hazard	31
1.9.7 Loss of machine control hazard	31
1.9.8 Chemical ingestion hazard	31
1.9.9 General safety alert hazard	31
1.9.10 Crushing hazard	32
1.9.11 Crushing hazard	32
1.9.12 Electrical shock hazard	32
1.9.13 Transporting hazard	32
1.9.14 Fall off hazard	33
1.9.15 Restrictor fitting	33
1.9.16 Pinch hazard	33
1.9.17 Flying objects hazard	33
1.9.18 Crushing hazard	34

1.9.19 Do not step hazard	34
1.9.20 Explosion hazard	34
1.9.21 Seed depth collar chart	34
1.9.22 Hopper capacity	35
1.9.23 Hopper capacity	35
1.9.24 Hydraulic lock-out valve	35
1.9.25 Plenum hydraulic valve	35
1.9.26 Reflector yellow	36
1.9.27 Reflector red	36
1.9.28 Reflector orange	36
1.9.29 SMV emblem	36
1.9.30 U.S. patents - A35911	37
1.9.31 Patent pending - A35495	37
2 Introduction	39
2.1 Introduction	41
2.1.1 Units of measurement	41
2.1.2 Replacement parts	41
2.1.3 Intended use	41
2.1.3.1 Proper disposal of waste	41
2.1.4 Proper disposal of waste	42
2.2 Machine identification	43
2.2.1 Serial number plate	43
2.2.2 Serial number description	43
2.3 Narrow-transport single disc drill	45
2.4 Major components	46
2.5 Operator manual storage	48
3 Operation	49
3.1 Ladder and platform	51
3.2 Product hopper lids	52
3.3 Jack handle extension	53
3.4 ISOBUS Harness Connector	54
3.5 Connecting the machine to the tractor	55
3.6 Disconnecting the machine from the tractor	57
3.7 Hydraulic systems	60
3.7.1 Drill to tractor hydraulic couplers	60
3.7.2 Bleeding air from the hydraulic lift system	60
3.7.3 Bleeding air from the hydraulic fold system	61
3.8 Frame height cylinder phasing	63
3.8.1 Putting the frame height cylinders in phase	63
3.9 Blower	64
3.9.1 Blower speed	64
3.10 Meters	65
3.10.1 Changing the metering wheels	65
3.10.2 Meter latches	65
3.10.3 Cleanout tray latches	66
3.10.4 Meter shaft adjustment	66
3.11 Plenum operation	67
3.11.1 Lowering the plenum for service and calibration	67
3.11.2 Cleaning out the plenum	67
3.12 Wireless blockage monitor	68
3.13 Preparing the machine for transport	69
3.14 Preparing the machine for seeding	70

3.15	Leveling the wings to the center frame	72
3.16	Adjusting the cast boot	73
3.17	Opening disc offset	74
3.17.1	Setting opening disc offset	75
3.18	Packing tires	76
3.19	Seed depth	77
3.19.1	Checking the seed depth	77
3.19.2	Seed depth collar sequences	78
3.19.3	Initial seed depth collar sequences	79
3.19.4	Adjusting seed depth	79
3.20	Toolbar down pressure	80
3.21	Turning at the edge of a field	81
3.22	Software information	82
3.22.1	Software icon descriptions	82
3.22.2	Main work screen	83
3.23	System information	86
3.23.1	Terminal information	86
3.23.2	Implement software identification	86
3.23.3	Master switch	86
3.23.3.1	External master switch	87
3.23.3.2	Terminal master switch	87
3.23.4	Virtual switch box	87
3.24	Implement setup	89
3.24.1	Changing the implement settings	89
3.24.2	Calibrate a drill section	89
3.24.3	Setting the down pressure	90
3.24.4	Setting the product rate	91
3.24.5	Loading the bins	92
3.25	Totals	93
3.26	Maintenance	94
4	Maintenance	95
4.1	Lubrication points	97
4.1.1	Lubrication and maintenance chart	97
4.1.2	Lubrication fitting locations	98
4.2	Servicing the wheel bearings	101
4.3	Storage	102
4.3.1	Preparing the machine for storage	102
4.3.2	Preventing corrosion of extended hydraulic cylinders	103
4.3.3	Removing the machine from storage	103
5	Troubleshooting	105
5.1	Troubleshooting	107
6	Specifications	113
6.1	Specifications	115
6.2	Transport dimensions	116
6.3	Minimum tow vehicle weight	117
6.4	Maximum transport speed	118
6.5	Lubrication specifications	119
6.6	Frame and rear hitch tire air pressure	120
6.7	SAE fastener torque specifications	121
6.8	Torque specifications for hydraulic tubes and fittings	122

6.9 Torque specifications for O-ring boss plugs, adjustable fitting lock nuts and JIC-37 seats	123
7 Accessories	125
7.1 Fertilizer bander attachment	127
7.1.1 Adjusting fertilizer bander depth	127
8 Assembly	129
8.1 Preparing for assembly	131
8.1.1 Service parts	131
8.2 Assembling the cast boot	132
8.3 Checklists	133
8.3.1 Pre-delivery checklist	133
8.3.2 Delivery checklist	133
9 Index	135

1. Safety

1.1 Introduction	9
1.1.1 Safety alert symbol	9
1.1.2 Safety messages	9
1.1.3 Informational messages	9
1.1.4 Safety signs	9
1.1.5 A word to the operator	10
1.1.6 This manual	11
1.2 Operation	12
1.2.1 Prepare for operation	12
1.2.2 General information	12
1.2.3 Personal protective equipment	13
1.2.4 Seat instructions	13
1.2.5 Shield and guards	14
1.2.6 Exhaust warning	14
1.2.7 Flying debris	15
1.2.8 Agricultural chemicals	15
1.3 Travel on public roads	16
1.4 Maintenance	18
1.4.1 General maintenance information	18
1.4.2 Fire prevention and first aid	19
1.4.3 High pressure leaks	20
1.4.4 Tire safety	21
1.4.5 Replacement parts	21
1.5 Wing lock pins	22
1.5.1 Installing the wing lock pins	22
1.5.2 Removing the wing lock pins	23
1.6 Toolbar locks	24
1.6.1 Locking the toolbar locks	24
1.6.2 Unlocking the toolbar locks	25
1.7 Hydraulic lock-out valves	27
1.8 Marker lamps	28
1.9 Safety and informational signs	29
1.9.1 Safety sign overview	29
1.9.2 Maximum speed sign	30
1.9.3 General safety alert hazard	30
1.9.4 General safety alert hazard	30
1.9.5 Negative tongue weight hazard	30
1.9.6 Hydraulic fluid injection hazard	31
1.9.7 Loss of machine control hazard	31
1.9.8 Chemical ingestion hazard	31
1.9.9 General safety alert hazard	31
1.9.10 Crushing hazard	32
1.9.11 Crushing hazard	32
1.9.12 Electrical shock hazard	32
1.9.13 Transporting hazard	32
1.9.14 Fall off hazard	33
1.9.15 Restrictor fitting	33
1.9.16 Pinch hazard	33
1.9.17 Flying objects hazard	33

1.9.18	Crushing hazard	34
1.9.19	Do not step hazard	34
1.9.20	Explosion hazard	34
1.9.21	Seed depth collar chart	34
1.9.22	Hopper capacity	35
1.9.23	Hopper capacity	35
1.9.24	Hydraulic lock-out valve	35
1.9.25	Plenum hydraulic valve	35
1.9.26	Reflector yellow	36
1.9.27	Reflector red	36
1.9.28	Reflector orange	36
1.9.29	SMV emblem	36
1.9.30	U.S. patents - A35911	37
1.9.31	Patent pending - A35495	37

1.1 Introduction

1.1.1 Safety alert symbol

The safety alert symbol means Attention! Become Alert! Your Safety Is Involved!

Look for the safety alert symbol both in this manual and on safety signs on this machine. The safety alert symbol will direct your attention to information that involves your safety and the safety of others.



Fig. 1

1.1.2 Safety messages

The words DANGER, WARNING or CAUTION are used with the safety alert symbol. Learn to recognize these safety alerts and follow the recommended precautions and safety practices.



DANGER:
Indicates an imminently hazardous situation that, if not avoided, will result in **DEATH OR VERY SERIOUS INJURY.**



WARNING:
Indicates a potentially hazardous situation that, if not avoided, could result in **DEATH OR SERIOUS INJURY.**



CAUTION:
Indicates a potentially hazardous situation that, if not avoided, may result in **MINOR INJURY.**



Fig. 2

1.1.3 Informational messages

The words important and note are not related to personal safety, but are used to give additional information and tips for operating or servicing this equipment.

IMPORTANT: *Identifies special instructions or procedures which, if not strictly observed, could result in damage to or destruction of the machine, process, or its surroundings*

NOTE: *Identifies points of particular interest for more efficient and convenient repair or operation.*

1.1.4 Safety signs



WARNING:
Do not remove or obscure safety signs. Replace any safety signs that are not readable or are missing. Replacement signs are available from your dealer in the event of loss or damage. The actual location of the safety signs is illustrated at the end of this section.

Keep signs clean by wiping off regularly. Use a mild soap and water solution if necessary.

If parts have been replaced or a used machine has been purchased, make sure all safety signs are present and in the correct location and can be read. Illustrations of safety sign locations are located at the rear of this section.

Replace any safety signs that can not be read, are damaged, or are missing. Clean the machine surface thoroughly with a mild soap and water solution before replacing signs. Replacement safety signs are available from your dealer.

1.1.5 A word to the operator

It is your responsibility to read and understand the safety section in this manual and the manual for all attachments before operating this machine. Remember you are the key to safety. Good safety practices not only protect you, but also the people around you.

Study the content in this manual and make the content a working part of your safety program. Keep in mind that this safety section is written only for this type of machine. Practice all other usual and customary safe working precautions, and above all remember - safety is your responsibility. You can prevent serious injury or death.

This safety section is intended to point out some of the basic safety situations that may be encountered during the normal operation and maintenance of your machine. This section also suggests possible ways of dealing with these situations. This section is not a replacement for other safety practices featured in other sections of this manual.

Personal injury or death may result if these precautions are not followed.

Learn how to operate the machine and how to use the controls properly.

Do not let anyone operate the machine without instruction and training.

For your personal safety and the personal safety of others, follow all safety precautions and instructions found in the manuals and on safety signs affixed to the machine and all attachments.

Use only approved attachments and equipment.

Make sure your machine has the correct equipment needed by the local regulations.

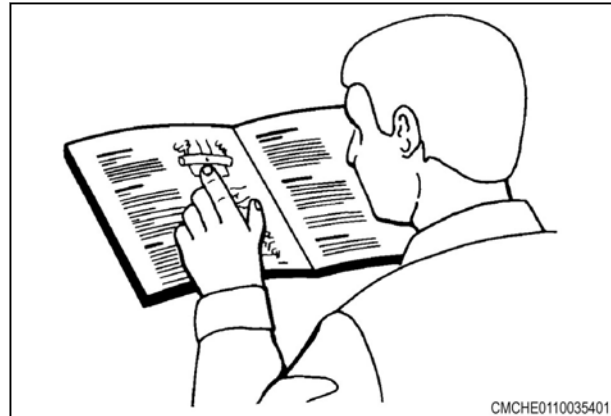

Fig. 3



WARNING:

An operator should not use alcohol or drugs which can affect their alertness or coordination. An operator on prescription or 'over the counter' drugs needs medical advice on whether or not they can properly operate machines.



CAUTION:
If any attachments used on this equipment have a separate Operator Manual, see that manual for other important safety information.

1.1.6 This manual

This manual covers general safety practices for this machine. The operator manual must always be kept with the machine.

Right-hand and left-hand, as used in this manual, are determined by facing the direction the machine will travel when in use.

The photos, illustrations, and data used in this manual were current at the time of printing, but due to possible in-line production changes, your machine can vary slightly in detail. The manufacturer reserves the right to redesign and change the machine as necessary without notification.



WARNING:
In some of the illustrations and photos used in this manual, shields or guards may have been removed for clarity. Never operate the machine with any shields or guards removed. If the removal of shields or guards is necessary to make a repair, they must be replaced before operation.

The Operator Manual is stored in the holder on the machine. After using the Operator Manual, return the manual to the storage location.

1.2 Operation

1.2.1 Prepare for operation

Read and understand all operating instructions and precautions in this manual before operating or servicing the machine.

Make sure you know and understand the positions and operations of all controls. Make certain all controls are in neutral and the park brake is applied before starting the machine.

Make certain all people are well away from your area of work before starting and operating the machine. Check and learn all controls in an area clear of people and obstacles before starting your work. Be aware of the machine size and have enough space available to allow for operation. Never operate the machine at high speeds in crowded places.

Emphasize the importance of using correct procedures when working around and operating the machine. Do not let children or unqualified persons operate the machine. Keep others, especially children, away from your area of work. Do not permit others to ride on the machine.

Make sure the machine is in the proper operating condition as stated in the Operator Manual. Make sure the machine has the correct equipment required by local regulations.

All equipment has a limit. Make sure you understand the speed, brakes, steering, stability and load characteristics of this machine and the tractor before you start.

1.2.2 General information

When parking, park the machine and the tractor on a solid level surface. put all controls in neutral and apply the tractor park brake. Stop the tractor engine and take the key with you.

Make sure the tractor and implement are in the proper operating condition according to the operator manuals. Make sure the tractor brakes and the machine brakes are adjusted correctly.

The tractor must have enough weight and braking capacity, especially when operating on roads and terrain that is not even. Use a tractor of recommended size and weight to tow the machine. See the machine specifications for the minimum tractor size and weight.

Tractor must be equipped with rollover protective structure (ROPS) and a seat belt. use seat belt during operation.

Do not dismount from moving machinery.

Always operate the machine with the terminal turned on.

Never start the tractor with the PTO engaged or terminal turned on.

Stay off slopes too steep for operation.

Where possible avoid operating the machine near ditches, embankments, and holes. Reduce ground speed when operating on rough, slippery, or muddy surfaces and when turning or crossing slopes.

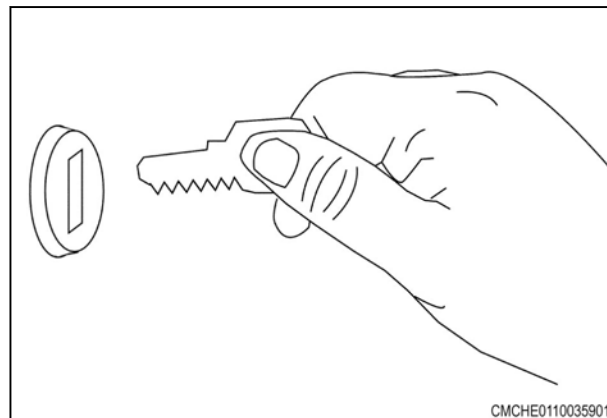

Fig. 4

Be aware of the size of the machine and have enough space available to allow for operation.

Always lower the machine when not in use and relieve the pressure in the hoses and cylinders.

Do not stand between the tractor and the implement to install the hitch pin when the tractor engine is running.

Avoid contact with electrical power lines. Contact with electrical power lines can cause electrical shock, resulting in very serious injury or death.

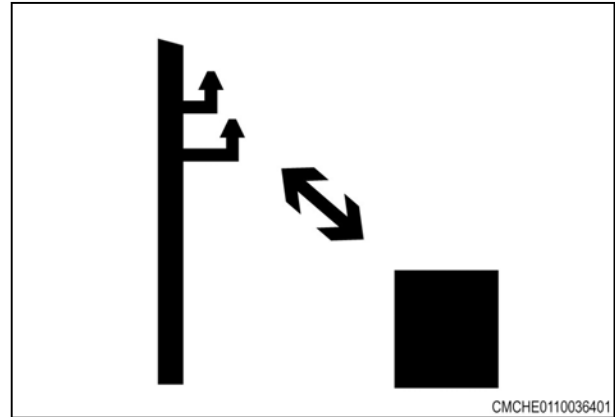

Fig. 5

1.2.3 Personal protective equipment

Wear all personal protective equipment (PPE) and protective clothing issued to you or called for by job conditions and country/local regulations. PPE includes, but is not limited to, equipment to protect eyes, lungs, ears, head, hands and feet when operating, servicing, or repairing equipment.

Always keep hands, feet, hair, and clothing away from moving parts. Do not wear loose clothing, jewelry, watches, or other items that could entangle in moving parts. Tie up long hair that can also entangle in moving parts.

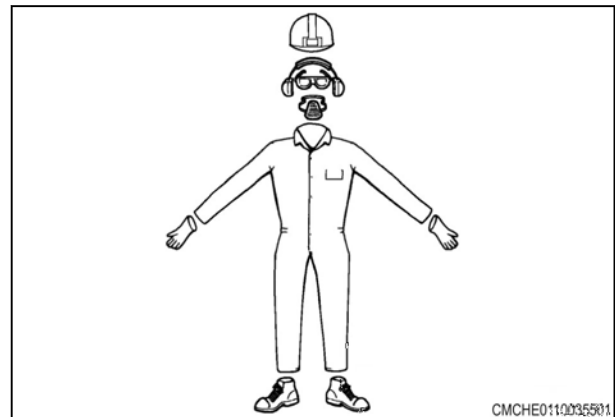

Fig. 6

1.2.4 Seat instructions

Securely fasten the seat belt before operating the machine. Always remain seated and have the seat belt fastened while operating the machine. Replace the seat belts when they become worn or broken.

Never wear a seat belt loosely or with slack in the belt system. Never wear the seat belt in a twisted condition or pinched between the seat structural members.

When using the instructional seat, if equipped, securely fasten the seat belt. The instructional seat is to be used only to train new operators or diagnose a problem. The instructional seat is only intended for short periods of use. Extra riders,

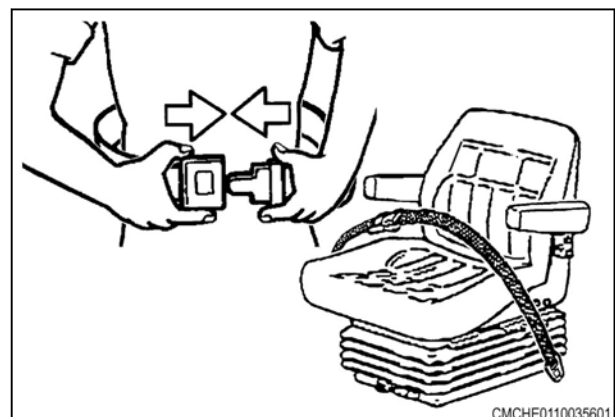

Fig. 7

especially children, are not permitted on the machine.

When the instructional seat is used the machine must be driven at a slower speed and on level ground. Avoid quick starts, stops, and sharp turns. Avoid driving on highways or public roads.

1.2.5 Shield and guards

All shields and guards must be in the correct operating position and in good condition.

Do not open, remove, or reach around shields while the engine is operating. Entanglement in rotating belts and components can cause serious injury or death. Stay clear of rotating components.

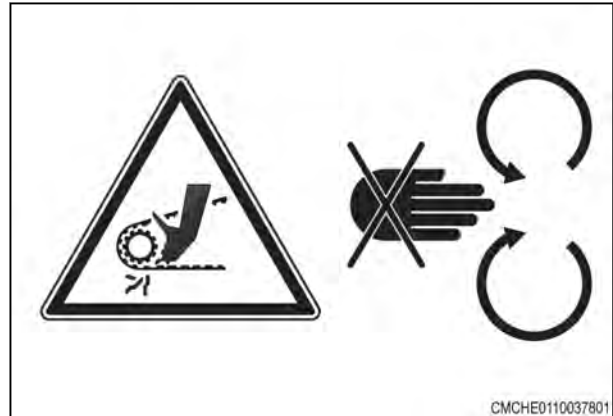

Fig. 8

Do not operate the machine with the drive shaft shields open or removed. Entanglement in rotating drive shafts can cause serious injury or death. Stay clear of rotating components.

Make sure rotating guards turn freely.



Fig. 9

1.2.6 Exhaust warning

Never operate the engine in a closed building unless the exhaust is vented outside.

Do not tamper with or modify the exhaust system with unapproved extensions.

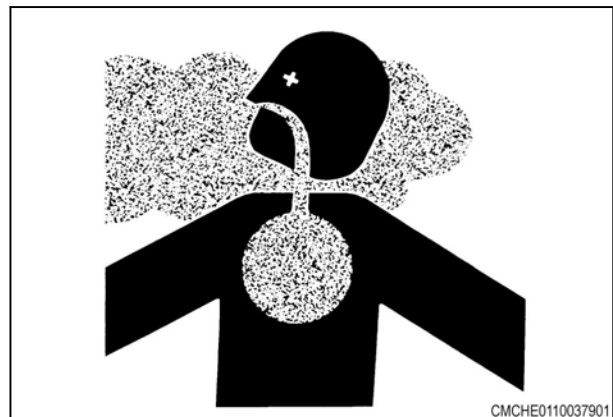

Fig. 10

1.2.7 Flying debris



WARNING:
Be careful when operating along the side of a road or building. Rocks or other debris can be thrown from the machine during operation possibly resulting in injury.

Never stand near the machine during operation. Debris can be thrown from the machine during operation possibly resulting in injury.



Fig. 11

1.2.8 Agricultural chemicals

Agricultural chemicals can be very hazardous. Improper use of fertilizer, fungicides, herbicides, insecticides and pesticides can injure people, plants, animals, soil and other people's property.

Always read and follow all manufacturers' instructions before opening any chemical container.

Even if you think you know the instructions, read and follow instructions each time you use a chemical.

Use the same precautions when adjusting, servicing, cleaning or storing the machine as used when installing chemicals into the hoppers or tanks.

Inform anyone who comes in contact with chemicals of the potential hazards involved and the safety precautions required.

Stand upwind and away from smoke from a chemical fire.

Store or dispose of all unused chemicals only in a manner as specified by the chemical manufacturer.

1.3 Travel on public roads

Make sure you understand the speed, brakes, steering, stability, and load characteristics of this machine before you travel on public roads.

Use good judgment when traveling on public roads. Maintain complete control of the machine at all times. Never coast down hills.

The maximum speed of farm equipment is governed by local regulations. Adjust travel speed to maintain control at all times.

Familiarize yourself with and obey all road regulations that apply to your machine. Consult your local law enforcement agency for local regulations regarding movement of farm equipment on public roads. Use head lamps, flashing warning lamps, tail lamps and turn signals, day and night, unless prohibited by local law.

Make sure all the flashers are operating prior to driving on the road. Make sure reflectors are correctly installed, in good condition, and wiped clean. Make sure the Slow Moving Vehicle (SMV) emblem is clean, visible, and correctly mounted on the rear of the machine.

Lock brake pedals together (if equipped with dual brake pedals) so both wheel brakes will be applied at the same time.

Raise implements to transport position and lock in place. Place all implements into narrowest transport configuration.

Disengage the power take-off and differential lock.

With towed implements, use a proper hitch pin with a clip retainer and safety transport chain.

Use a safety transport chain with a strength rating equal to or more than the gross weight of the towed machine.

Connect the safety transport chain to the tractor drawbar and use a retainer on the hitch pin.

Supply only enough slack in the safety transport chain to permit turning.

Do not use the safety transport chain as a tow chain for towing.

Be aware of other traffic on the road. Keep well over to your own side of the road and pull over, whenever possible, to let faster traffic pass.

Be aware of the overall width, length, height, and weight of the machine. Be careful when transporting the machine on narrow roads and across narrow bridges.

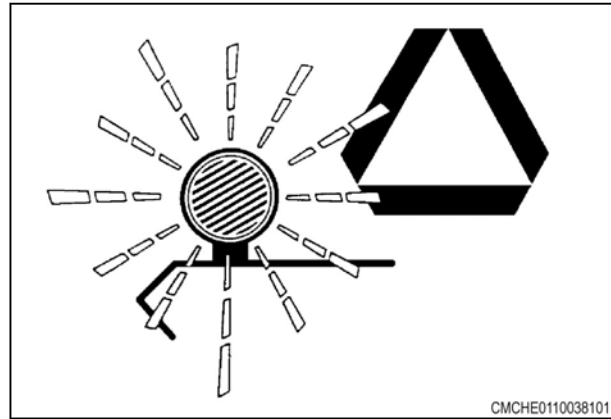

Fig. 12

Watch for overhead wires and other obstructions. Avoid contact with electrical power lines. Contact with electrical power lines can cause electrical shock, resulting in very serious injury or death.

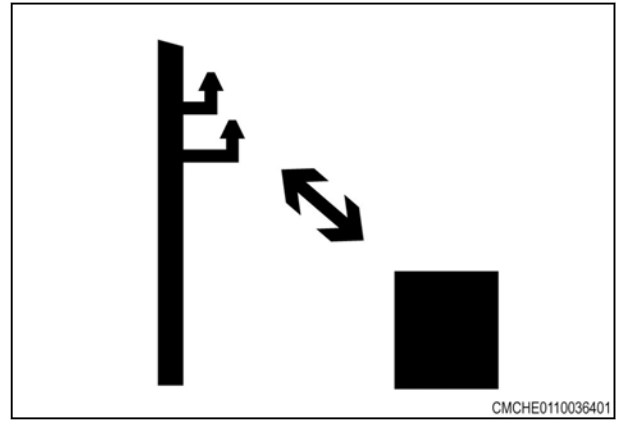

Fig. 13

1.4 Maintenance

1.4.1 General maintenance information

Before doing any unplugging, lubricating, servicing, cleaning, or adjusting:

- Park the machine on a solid level surface.
- Make sure all controls are in the neutral position and apply the park brake.
- Make sure the machine and attachments have been lowered to the ground.
- Stop the engine and take the key with you.
- Look and Listen! Make sure all moving parts have stopped.
- Put blocks in front of and behind the wheels of the machine before working on or under the machine.

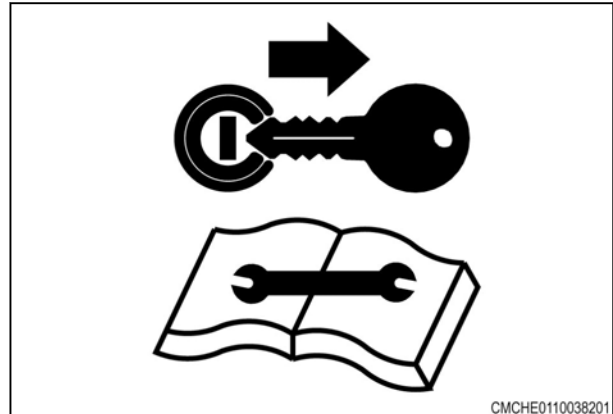

Fig. 14

Do not leave the tractor or the machine unattended with the engine running.

Do not pull crop or any other object from the machine while the machine engine is running. Moving parts can pull you in faster than you can move away.

Check all nuts and bolts periodically for tightness, especially wheel mounting hardware.

Do not attempt to service or adjust the machine until all moving parts have stopped.

Check all nuts and bolts periodically for tightness, especially wheel mounting hardware.

Be aware of the size of parts when doing service work. Never stand under or near a part being moved with lifting equipment.

After unplugging, lubricating, servicing, cleaning, or adjusting the machine make sure all tools and equipment have been removed.

Make sure electrical connectors are clean and free of dirt or grease before connecting.

Check for loose, broken, missing, or damaged parts. Make sure the machine is in good repair. Make sure all guards and shields are in position.

Always raise the machine, shut off tractor engine, apply the parking brake, shift to park position (or neutral) remove the key and install the cylinder stops channels before working around the machine.

Avoid working under the machine. However, if it becomes unavoidable to do so, make sure the machine is securely blocked and the cylinder lockup channels are in position.

Never service, check or adjust drive chains or belts while the engine is running.



Fig. 15

Do not operate the machine with the drive shaft shields open or removed. Entanglement in rotating drive shafts can cause serious injury or death.

Stay clear of rotating components.

Make sure rotating guards turn freely.

A loose yoke can slip off a shaft and result in injury to persons or damage to the machine.

When installing a quick disconnect yoke, the spring activated locking pins must slide freely and be seated in the groove on the shaft. Pull on the driveline to make sure the quick disconnect yoke can not be pulled off the shaft.

Remove spilled oil, antifreeze or fuel immediately from the steps, platform, and other access areas.

Keep all access areas clean and free of obstructions.



Fig. 16



Fig. 17

1.4.2 Fire prevention and first aid

Be prepared for emergencies.

Keep a first aid kit handy for treatment of minor cuts and scratches.

Always carry one or more fire extinguishers of the correct type. Check fire extinguishers regularly as instructed by the manufacturer. Make sure fire extinguishers are properly charged and in operating condition.

Due to the nature of the crops this machine will operate in, the risk of fire is of concern. Use a water type fire extinguisher or other water source for a fire in crop.

For fires involving anything other than crop, such as oil or electrical components, use a dry chemical fire extinguisher with an ABC rating.

Mount fire extinguishers within easy reach of where fires can occur.

Frequently remove accumulated crop material from the machine and check for overheated components. Check the machine daily for any noises that are not normal. Such noises could indicate a failed component that can cause excess heat.



Fig. 18

If any flame cutting, welding, arc welding, or grinding is to be done on the machine or attachments, make sure to clear any crop material or debris from around the area. Make sure the area below the work area is clear of any flammable material as falling molten metal or sparks can ignite the material.

If fire occurs stand upwind and away from smoke from the fire.

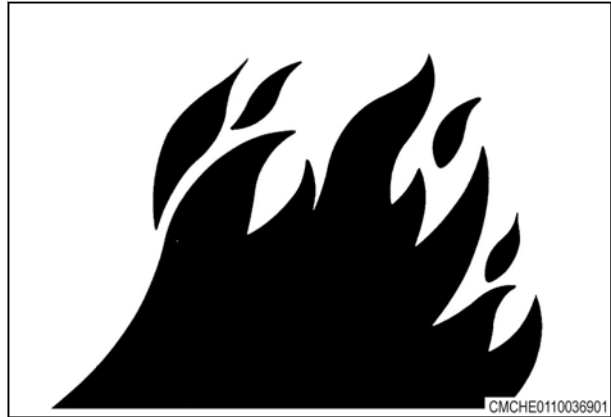

Fig. 19

1.4.3 High pressure leaks

Fluid leaking from the hydraulic system or the fuel injection system under high pressure can be very hard to see. The fluid can go into the skin causing serious injury.

Fluid injected into the skin must be surgically removed within a few hours. If not removed immediately, serious infection or reaction can develop. Go immediately to a doctor who knows about this type of injury.



Fig. 20

Use a piece of cardboard or wood to search for possible leaks. Do not use your bare hand. Wear leather gloves for hand protection and safety goggles for eye protection.

Relieve all pressure before loosening any hydraulic lines. Relieve the pressure by lowering raised equipment, shutting off accumulator valve, if equipped, and shutting off the engine. Tighten all connections securely before applying pressure.

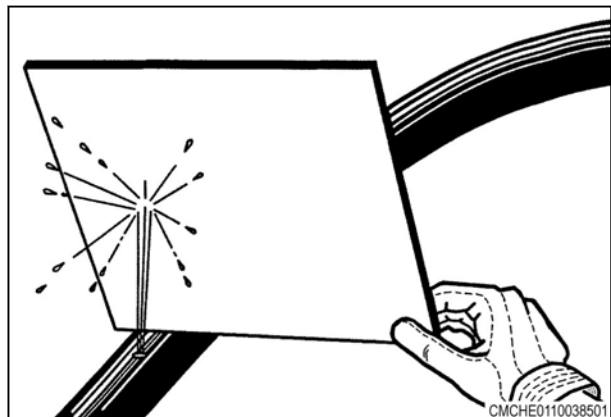

Fig. 21

1.4.4 Tire safety

Check tires for cuts, bulges, and correct pressure. Replace worn or damaged tires. When tire service is needed, have a qualified tire mechanic service the tire. Tire changing can be very hazardous and must be done by qualified tire mechanic using proper tools and equipment. See the Specifications Section for the correct tire size.

Tire explosion and/or serious injury can result from over inflation. Do not exceed the tire inflation pressures. See the Specifications Section for the correct tire pressure.

Do not inflate a tire that is seriously under inflated or has been run flat. Have the tire checked by qualified tire mechanic.

Do not weld on the rim when a tire is installed. Welding will make an air/gas mixture that can cause an explosion and burn with high temperatures. This hazard applies to all tires, inflated or deflated. Removing air or breaking the bead is not enough. The tire must be completely removed from the rim prior to welding.

When preparing a calcium chloride solution for fluid ballast the tractor tires, never pour water onto the calcium chloride. A chlorine gas can be generated which is poisonous and explosive. This can be avoided by slowly adding calcium chloride flakes to water and stirring until they are dissolved.

When seating tire beads onto rims, never exceed 2.4 bar (35 psi) or the maximum inflation pressure specified on the tire. Inflation beyond this maximum pressure may break the bead, or even the rim, with explosive force.



Fig. 22

CMCHE0110039401

1.4.5 Replacement parts

Where replacement parts are necessary for periodic maintenance and servicing, genuine replacement parts must be used to restore your equipment to original specifications.

The manufacturer will not accept responsibility for installation of unapproved parts and/or accessories and damages as a result of their usage.

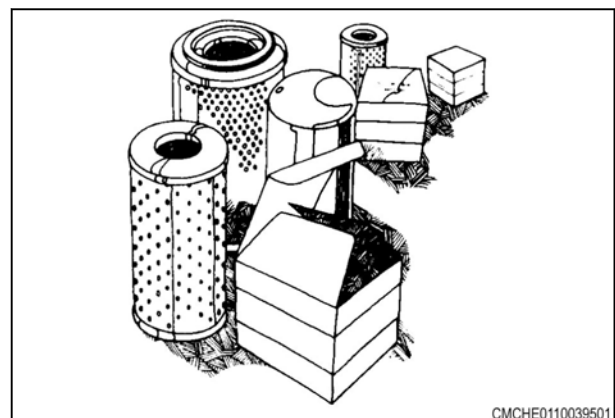

Fig. 23

CMCHE0110039501

1.5 Wing lock pins

The machine is equipped with two wing lock pins. The wing lock pins are used to lock the wings in the raised or folded position. Install the wing lock pins when transporting or servicing the drill.

When unlocking the wings, keep the wing lock pins (1) and wire lock pins in the brackets (2) located on the main frame (3). The wing lock brackets are located at the hinge points of each wing.

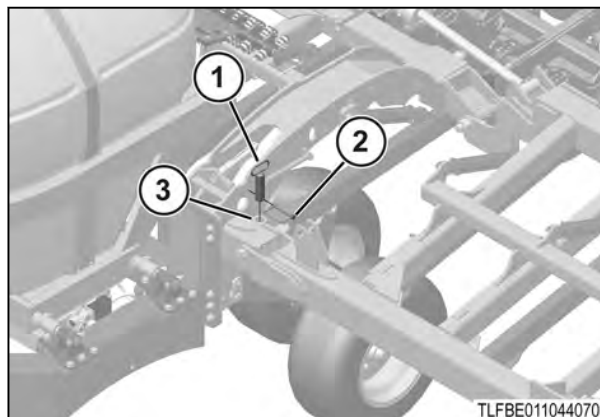

Fig. 24

1.5.1 Installing the wing lock pins

Install the wing lock pins when the machine is to be transported or serviced with the wing in the raised or folded position.

Procedure

1. Use the tractor hydraulics to fully lift the wings of the machine.
2. Stop the engine, set the tractor park brake, and take the ignition key with you.
3. Remove the wire lock pin (2) from the end of the wing lock pin (1).
4. Remove the wing lock pin (1) from the storage bracket (3).

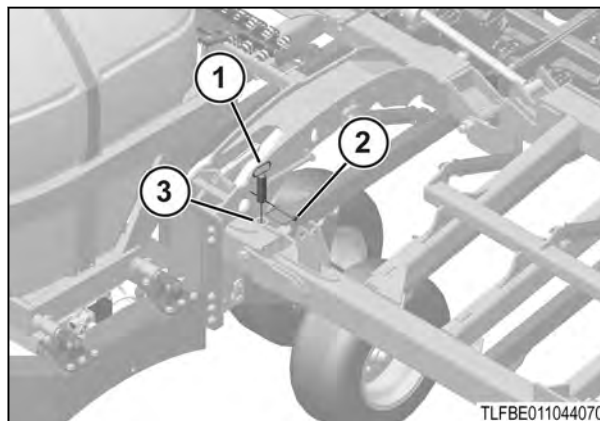

Fig. 25

5. Install the wing lock pin (1) through the holes in the wing lock brackets (3).
6. Install the wire lock pin (2) in the end of the wing lock pin.

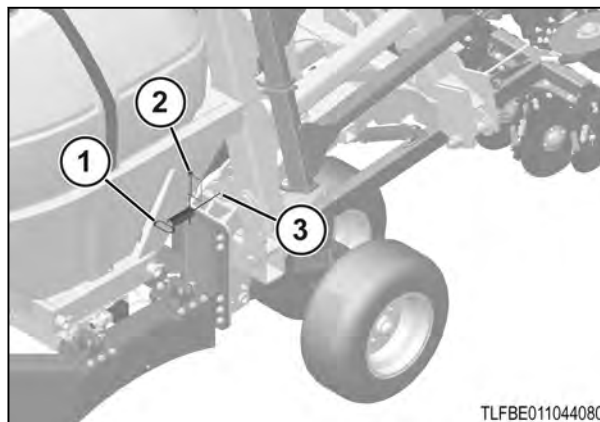

Fig. 26

7. Use the same procedure to install the remaining wing lock pins in the wing lock brackets on the remaining hinge points.

1.5.2 Removing the wing lock pins

Remove the wing lock pins before lowering the wings of the machine.

Procedure

1. Use the tractor hydraulics to remove any load from the wing lock pins by completely raising the wings.
2. Stop the engine, set the tractor park brake, and take the ignition key with you.
3. Remove the wire lock pin (2) from the end of the wing lock pin (1).
4. Remove the wing lock pin (1) from the wing lock brackets (3).

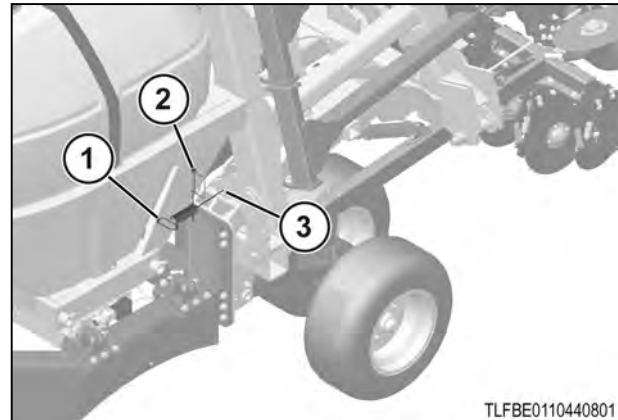

Fig. 27

5. Install the wing lock pin (1) in the storage bracket (3) on the main frame of the machine.
6. Install the wire lock pin (2) in the end of the wing lock pin (1).

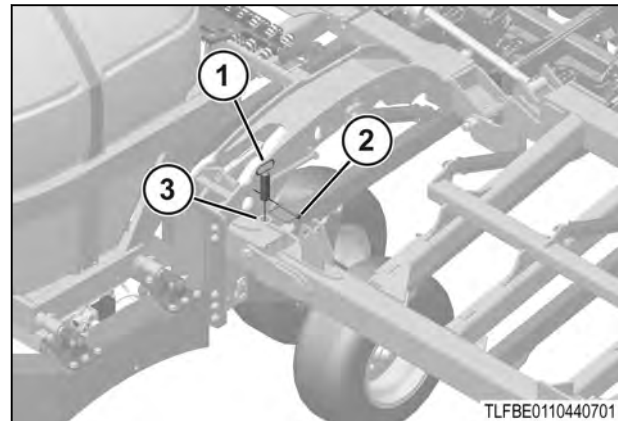

Fig. 28

7. Remove the remaining wing lock pins from the wing lock brackets of the remaining hinge points.
8. Use the tractor hydraulics to lower the wings to the ground.

1.6 Toolbar locks

Each toolbar has a toolbar lock (1). A toolbar lock tool is used to turn the lock in the slot (2) and lock the toolbar. The toolbar locks are used to lock the toolbars in the lifted position. Engage the toolbar locks when transporting the drill or servicing the toolbars.

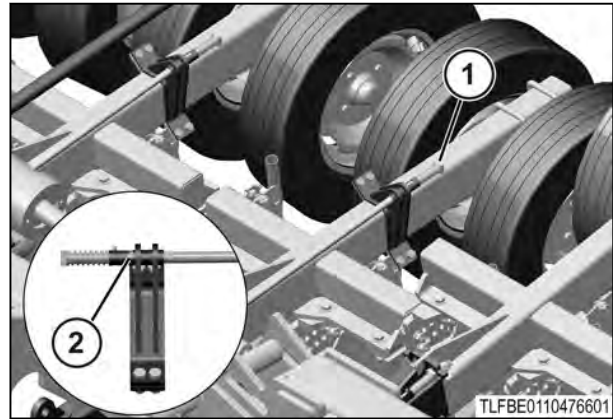

Fig. 29

1.6.1 Locking the toolbar locks

Lock the toolbars before transporting the drill or servicing the toolbars.

Procedure

1. Use the tractor hydraulics to fully lift the toolbars.
2. Stop the engine, set the tractor park brake, and take the ignition key with you.
3. Remove the toolbar lock tool (1) from the storage position (2). Remove the wire lock pin (3) that attaches the toolbar lock to the light bar assembly.

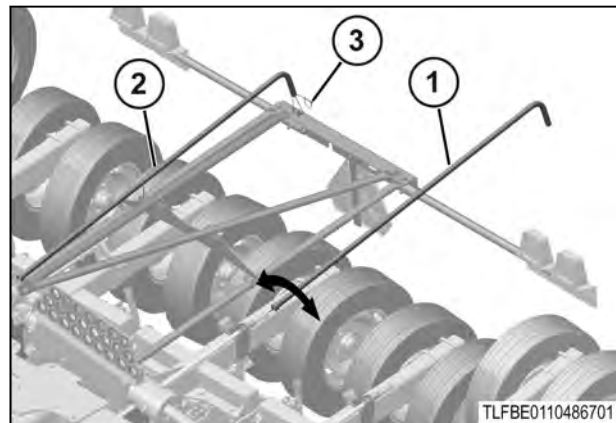

Fig. 30

4. Use the toolbar lock tool to push in and turn the lock (1) clockwise to the locked position (2).
The toolbar is locked when the lock is pushed in and fully turned into the slot.
5. Use the same procedure to lock the remaining toolbars on the machine.

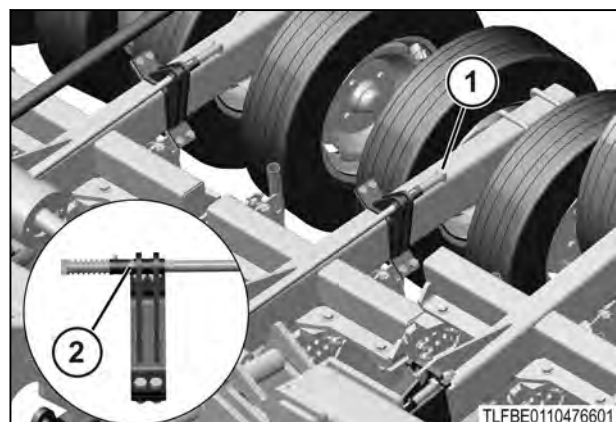

Fig. 31

6. Put the toolbar lock tool (1) in the storage position (2) when complete.
7. Attach the toolbar lock tool to the light bar assembly with the wire lock pin (3).

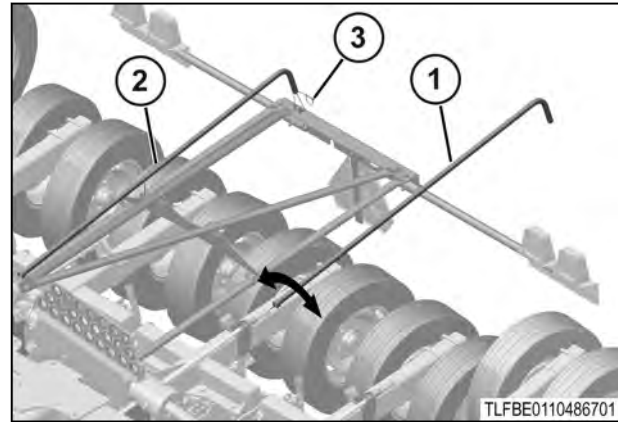

Fig. 32

1.6.2 Unlocking the toolbar locks

Unlock the toolbars before operation in the field.

Procedure

1. Use the tractor hydraulics to fully lift the toolbars to remove the load.
2. Stop the engine, set the tractor park brake, and take the ignition key with you.
3. Remove the toolbar lock tool (1) from the storage position (2). Remove the wire lock pin (3) that attaches the toolbar lock to the light bar assembly.

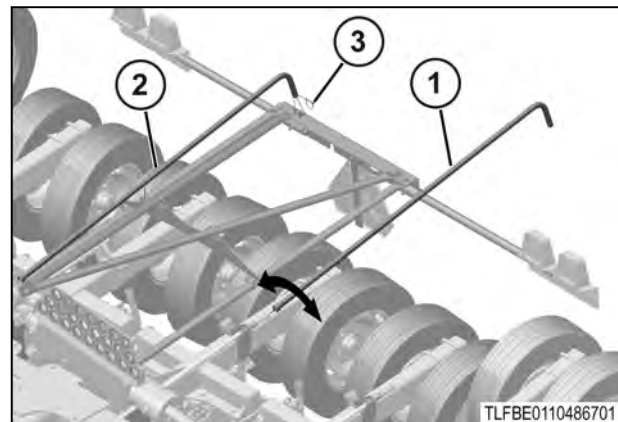

Fig. 33

4. Use the toolbar lock tool to push and turn the lock (1) counter-clockwise to the unlocked position (2). The toolbar is unlocked when released from the slot and extended back.
5. Use the same procedure to unlock the remaining toolbars on the drill.

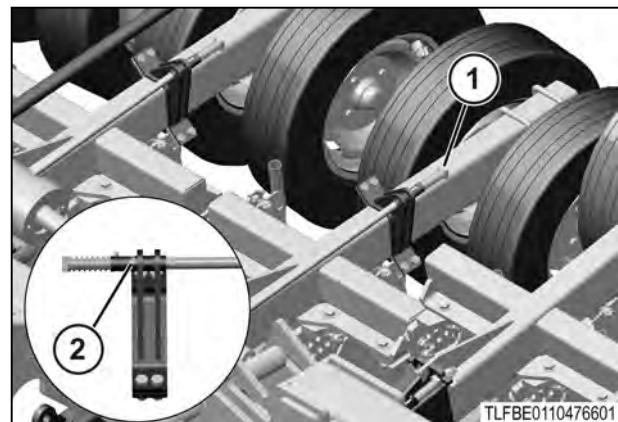

Fig. 34

6. Put the toolbar lock tool (1) in the storage position (2) when complete.
7. Attach the toolbar lock tool to the light bar assembly with the wire lock pin (3).

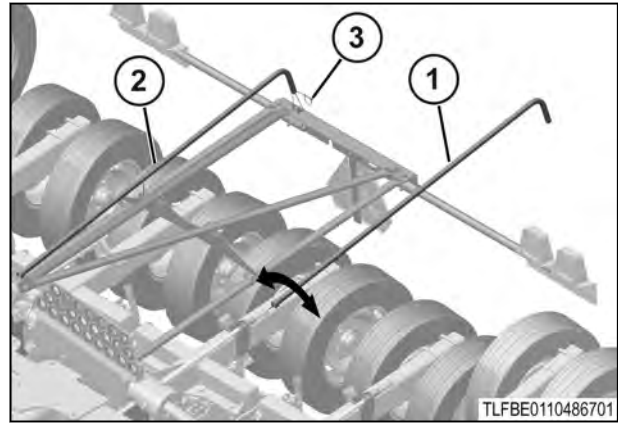

Fig. 35

1.7 Hydraulic lock-out valves

The hydraulic lock-out valve is on the front of the frame, on the left-hand side of the front hitch.

The toolbar lock-out valve (1) is installed on all drills. The toolbar lock-out valve is used to hydraulically lock the toolbars in the transport or raised position.



WARNING:
The toolbars can drop to the ground when the toolbar lock-out valve is opened. Make sure the area below the toolbars is clear of people and obstructions before opening the toolbar lock-out valve.

Move the valve handle so the handle is parallel to the frame to put the lock-out valve in the open position (1). In the open position hydraulic pressure can flow through the valve.

Move the valve handle up to put the lock-out valve in the closed position (2). In the closed position the hydraulic pressure will not flow through the valve.

IMPORTANT: *Open the valve when seeding and close the valve when transporting the drill.*

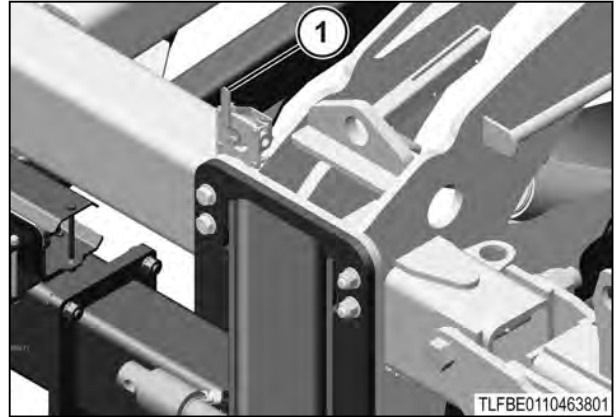

Fig. 36

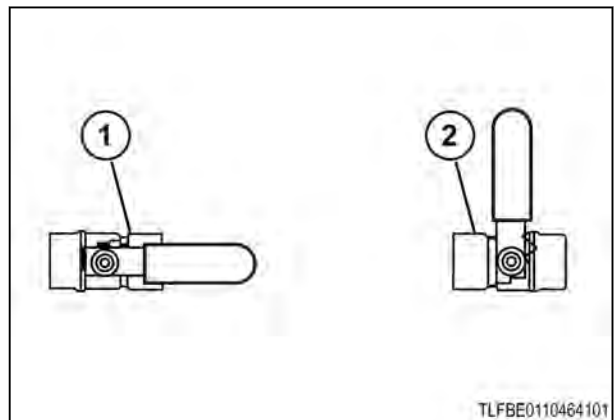

Fig. 37

1.8 Marker lamps

The machine has marker lamps that must be used when moving the machine on roads.

The machine is equipped with two amber lamps (1) located at the outside edges of the machine.

The machine is equipped with two red lamps (2) located toward the center of the machine.

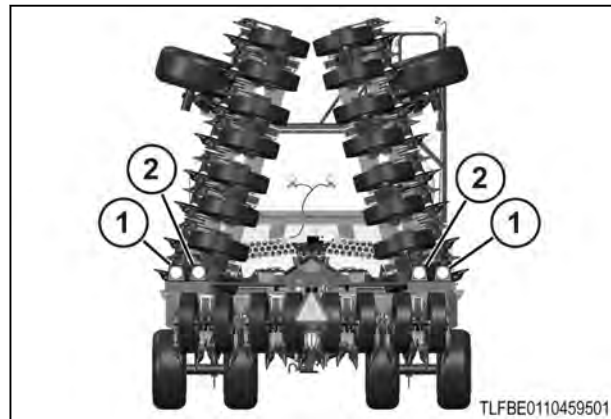

Fig. 38

1.9 Safety and informational signs

1.9.1 Safety sign overview

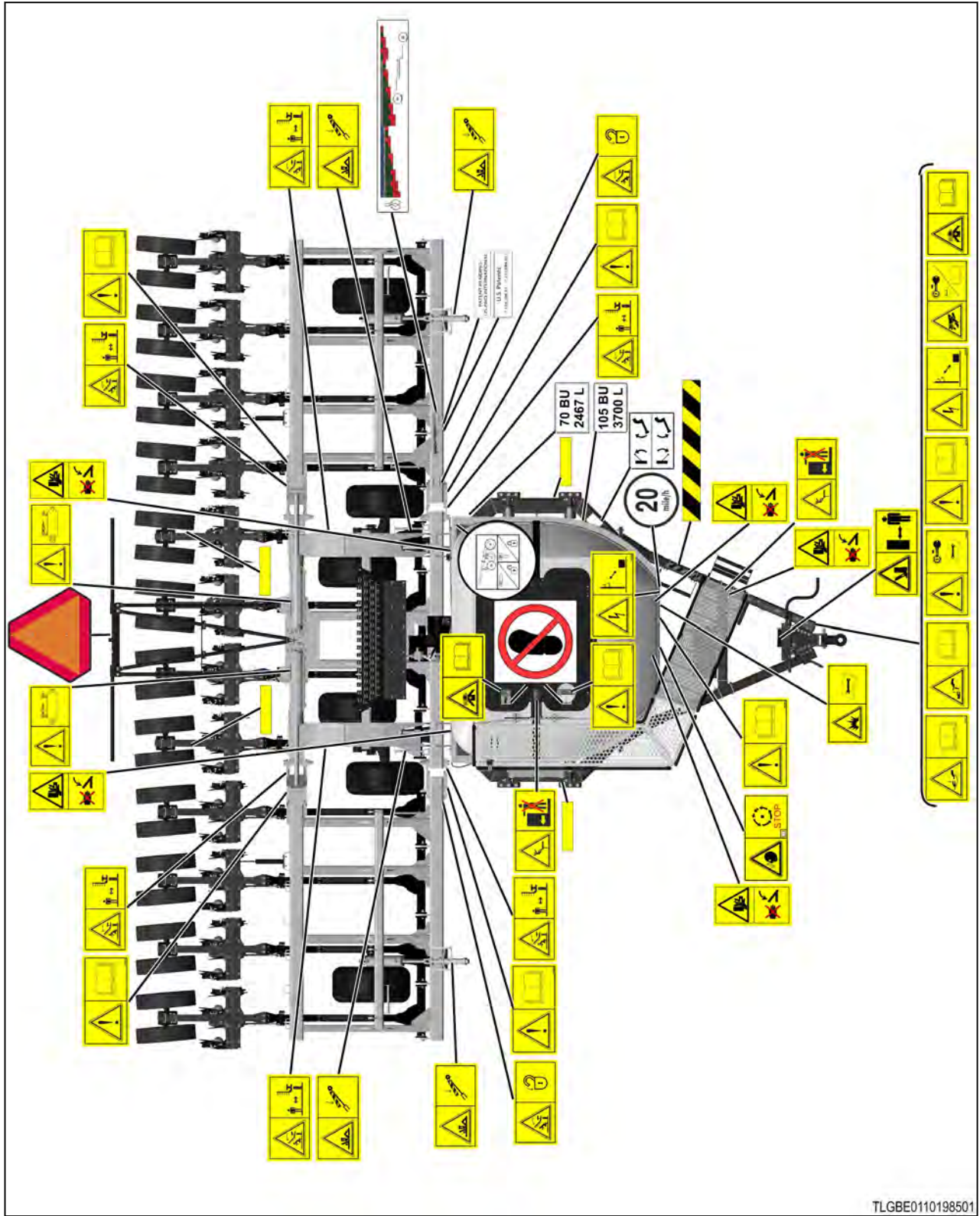



Fig. 39 The top view of the machine.

1.9.2 Maximum speed sign

Maximum speed sign	
 <p>TLFBE0110454901</p>	<p>Maximum speed sign</p> <p>The maximum speed instructional sign displays the maximum speed the machine can be transported.</p>

1.9.3 General safety alert hazard

General safety alert hazard	
 <p>TLFBE0110389701</p>	<p>General safety alert</p> <p>Read and understand the operator manual before operating the machine.</p>

1.9.4 General safety alert hazard

General safety alert hazard	
 <p>TLFBE0110389601</p>	<p>General safety alert</p> <p>Shut off the engine and remove the key before performing maintenance or repair work.</p>

1.9.5 Negative tongue weight hazard

Negative tongue weight hazard	
 <p>TLFBE0110389501</p>	<p>Negative tongue weight will cause immediate elevation of the tongue</p> <p>Stay clear of the tongue when disconnecting the implement from the tractor. Read the operator manual for safety information and operating instructions before operating the machine.</p>

1.9.6 Hydraulic fluid injection hazard

Hydraulic fluid injection hazard	
 <p>TLFBE0110389901</p>	<p>Injection hazard into skin - escaping fluid is under high pressure</p> <p>Shut off engine, remove the key, and relieve pressure before performing maintenance or repair work. Refer to the operator manual for proper service procedures.</p>

1.9.7 Loss of machine control hazard

Loss of machine control hazard	
 <p>TLFBE0110389401</p>	<p>Loss of machine control</p> <p>Install the safety chains when attaching the machine to the tractor. Read the operator manual for safety information and operating instructions before operating the machine.</p>

1.9.8 Chemical ingestion hazard

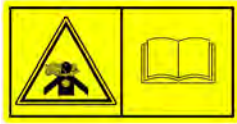
Chemical ingestion hazard	
 <p>TLFBE0110454501</p>	<p>Dust/fumes inhalation hazard - risk of asphyxiation</p> <p>Refer to the Operator's Manual for safety information and operating instructions and chemical manufacturers instructions before operating the machine.</p>

1.9.9 General safety alert hazard

General safety alert hazard	
 <p>TLFBE0110454401</p>	<p>General safety alert</p> <p>Watch your step</p>

1.9.10 Crushing hazard

Crushing hazard	
 TLFBE0110454601	<p>Crushing hazard from lowering or falling wing</p> <p>Stay clear of this area while engine and machine are operating. For service work, install the wing lock pins before getting under wing.</p>

1.9.11 Crushing hazard

Crushing hazard	
 TLFBE0110390101	<p>Crushing hazard</p> <p>Stay clear of this area while engine and machine are operating. For service work, install the lock pins before getting under the machine.</p>

1.9.12 Electrical shock hazard

Electrical shock hazard	
 TLFBE0110389801	<p>Electrical shock hazard - risk of personal injury and component damage</p> <p>Keep sufficient distance away from electrical power lines.</p>

1.9.13 Transporting hazard

Transporting hazard	
 TLFBE0110454701	<p>Transporting hazard</p> <p>Install wing fold lock pins before transporting. To prevent machine damage, remove the pins before unfolding the machine.</p>

1.9.14 Fall off hazard

Fall off hazard	
 <p>TLFB E0110455001</p>	<p>Fall off hazard Do not ride on this machine.</p>

1.9.15 Restrictor fitting

Restrictor fitting	
 <p>TLFB E0110454301</p>	<p>Risk of injury and component damage Be sure to install restrictor when servicing or assembling.</p>

1.9.16 Pinch hazard

Pinch hazard	
 <p>TLFB E0110454801</p>	<p>Pinch hazard - risk of personal injury Keep hands clear.</p>

1.9.17 Flying objects hazard

Flying objects hazard	
 <p>TLFB E0110455101</p>	<p>Flying objects hazard - risk of personal injury Stop fan before lowering plenum for calibration or service. Stay clear when machine is operating.</p>

1.9.18 Crushing hazard

Crushing hazard	
 <p>TLFBE0110455301</p>	<p>Keep foot clear - risk of personal injury</p> <p>Keep foot clear while operating jack.</p>

1.9.19 Do not step hazard

Do not step hazard	
 <p>TLFBE0110455701</p>	<p>Do not step on this surface.</p>

1.9.20 Explosion hazard

Explosion hazard	
 <p>TLFBE0110455201</p>	<p>Explosion hazard - rotor is turning at high speeds</p> <p>Shut off engine, remove key and relieve pressure before performing maintenance or repair work. See service manual for proper repair procedures.</p>

1.9.21 Seed depth collar chart

Seed depth collar chart	
 <p>TLFBE0110455401</p>	<p>Seed depth collar chart</p>

1.9.22 Hopper capacity

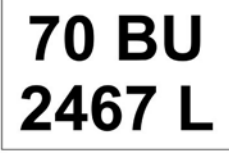
Hopper capacity	
 <p>70 BU 2467 L</p> <p>TLFBE0110455501</p>	<p>Hopper capacity 2467 L (70 bu)</p>

1.9.23 Hopper capacity

Hopper capacity	
 <p>105 BU 3700 L</p> <p>TLFBE0110455601</p>	<p>Hopper capacity 3700 L (105 bu)</p>

1.9.24 Hydraulic lock-out valve

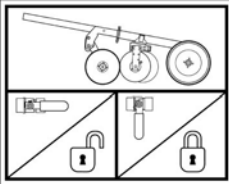
Hydraulic lock-out valve	
 <p>TLFBE0110516901</p>	<p>Hydraulic lock-out valve Locked/Unlocked</p>

1.9.25 Plenum hydraulic valve

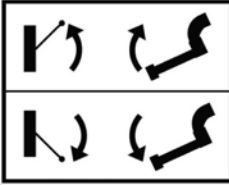
Plenum hydraulic valve	
 <p>TLFBE0110517001</p>	<p>Plenum hydraulic valve</p>

1.9.26 Reflector yellow

Reflector, yellow	
	Reflector, yellow

1.9.27 Reflector red

Reflector, red	
	Reflector, red

1.9.28 Reflector orange

Reflector, orange	
	Reflector, orange

1.9.29 SMV emblem

SMV emblem	
	SMV (slow moving vehicle) emblem

1.9.30 U.S. patents - A35911

Hopper capacity	
<div style="border: 1px solid black; padding: 5px; width: fit-content; margin: 0 auto;">U.S. Patents 7,104,206 B1 7,216,596 B2</div> <p style="text-align: center; margin-top: 20px;">TLGBE0110197801</p>	U.S. patents

1.9.31 Patent pending - A35495

Hopper capacity	
<div style="border: 1px solid black; padding: 5px; width: fit-content; margin: 0 auto;">PATENT PENDING US AND INTERNATIONAL</div> <p style="text-align: center; margin-top: 20px;">TLGBE0110197701</p>	Patent pending

2. Introduction

2.1 Introduction	41
2.1.1 Units of measurement	41
2.1.2 Replacement parts	41
2.1.3 Intended use	41
2.1.3.1 Proper disposal of waste	41
2.1.4 Proper disposal of waste	42
2.2 Machine identification	43
2.2.1 Serial number plate	43
2.2.2 Serial number description	43
2.3 Narrow-transport single disc drill	45
2.4 Major components	46
2.5 Operator manual storage	48

2.1 Introduction

**CAUTION:**

In some of the illustrations used in this Operator Manual, panels or guards may have been removed for clarity. Never operate the tractor with these panels and guards removed. If the removal of a shield is necessary to make a repair, it must be replaced before operation.

**CAUTION:**

Read this book in its entirety prior to operating machine. Use only genuine replacement parts for repairs and/or replacement.

This manual gives the operator the proper instructions needed for operation and maintenance. Read, understand, and follow these instructions for best machine performance and life. With proper maintenance and operation procedures, the machine will have better over all performance. Use normally available tools for maintenance on this machine.

All operators must read and understand this manual before operating this machine. Where possible, operators who have not operated the machine must receive instruction from an operator who has operated this machine. Your dealer can give instruction in machine operation. Keep this manual with the machine for future reference. If the original manual is damaged, order a replacement from your dealer.

See your dealer in for any service problems and adjustments. The dealer is equipped for all service work and to help with specific applications of the tractor in local conditions.

Left-hand and right-hand are determined by facing the direction the machine will travel when in use.

2.1.1 Units of measurement

Measurements are given in metric units followed by the equivalent in US units. Hardware sizes are given in millimeters for metric hardware and inches for US hardware.

2.1.2 Replacement parts

To receive prompt efficient service, remember to have the following information:

- Correct part description and part number
- Model number of the machine
- Serial number of the machine

2.1.3 Intended use

This machine is designed solely for use in customary agricultural operations.

Do not use this machine for any application or purpose other than those described in this manual. The manufacturer accepts no liability for damage or injury resulting from misuse of this machine.

Compliance with the conditions of operation, service and repair as specified by the manufacturer constitute essential elements for the intended use of this machine.

This machine should be operated, serviced and repaired only by qualified persons familiar with its characteristics and familiar with the relevant safety rules and procedures.

All generally recognized safety regulations and road traffic regulations must be obeyed at all times.

Any unauthorized modifications performed on this machine will relieve the manufacturer of all liability for any resulting damage or injury.

2.1.3.1 Proper disposal of waste

Improper disposal of waste can pollute the environment and ecology. A few examples of potentially harmful equipment waste can include, but not limited to, items such as oil, fuel, coolant, brake fluid, filters, battery chemicals, tires, etc.

Use leak proof containers when draining fluids. Do not use food or beverage containers to collect waste fluids, as food or beverage container(s) may mislead someone into drinking from them.

Do not pour or spill waste onto the ground, down a drain, or into any water source.

Air conditioning refrigerants escaping into the air can damage the Earth's atmosphere. Government regulations may require a certified air conditioning service center to recover and recycle used air conditioning refrigerants.

Inquire with local environmental or recycling center on the proper way to recycle or dispose waste.

2.1.4 Proper disposal of waste

Improper disposal of waste can pollute the environment and ecology. A few examples of potentially harmful equipment waste can include, but not limited to, items such as oil, fuel, coolant, brake fluid, filters, battery chemicals, tires, etc.

Use leak proof containers when draining fluids. Do not use food or beverage containers to collect waste fluids, as food or beverage container(s) may mislead someone into drinking from them.

Do not pour or spill waste onto the ground, down a drain, or into any water source.

Air conditioning refrigerants escaping into the air can damage the Earth's atmosphere. Government regulations may require a certified air conditioning service center to recover and recycle used air conditioning refrigerants.

Inquire with local environmental or recycling center on the proper way to recycle or dispose waste.

2.2 Machine identification

Each machine is identified by a model and a serial number.

Record these numbers in the spaces given.

Give the model number and serial number to your dealer when parts or service are required.

Machine model number: _____

Machine serial number: _____

Date of delivery: _____

Dealer name: _____

Dealer address: _____

Dealer telephone number: _____

Dealer e-mail address: _____

Dealer fax number: _____

2.2.1 Serial number plate

The serial number plate (1) is located on the front of the center frame.

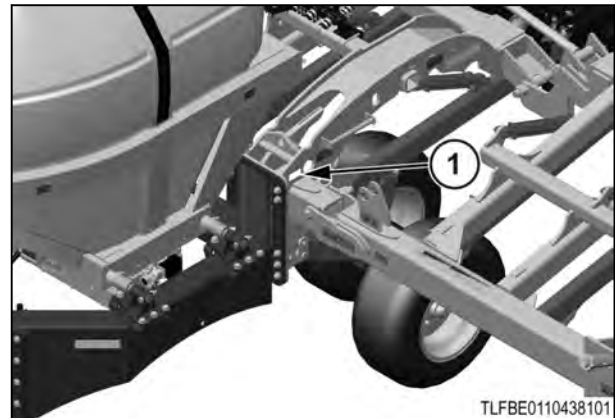

Fig. 1

2.2.2 Serial number description

Description of the serial number for model year 2010 and up.

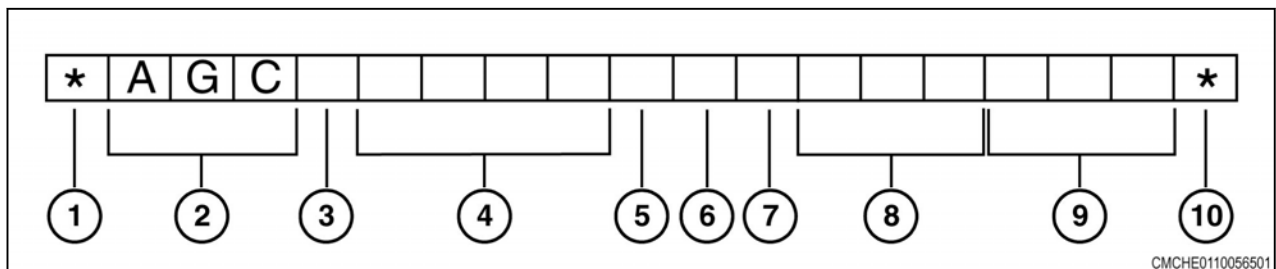

Fig. 2

- | | |
|-------------------------------------|---|
| (1) Beginning symbol | (5) Check letter (0 or used if model identifier is five digits) |
| (2) World manufacturer code | (6) Model year code (A=2010, B=2011, C=2012, and on) |
| (3) Brand code | |
| (4) Model identifier (model number) | |

(7) Plant code
(8) Family code

(9) Unit number for the year
(10) Ending symbol

2.3 Narrow-transport single disc drill

The narrow-transport single disc drill is designed to seed in a range of soil conditions from no till with heavy residue to conventional till. The single disc drill can seed in these conditions without adjusting the openers. An air distribution system is used to distribute the seed to each of the openers. The drill is monitored using a display in the cab of the tractor.

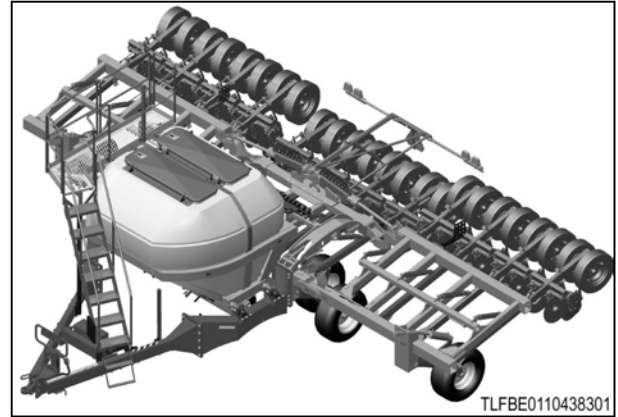
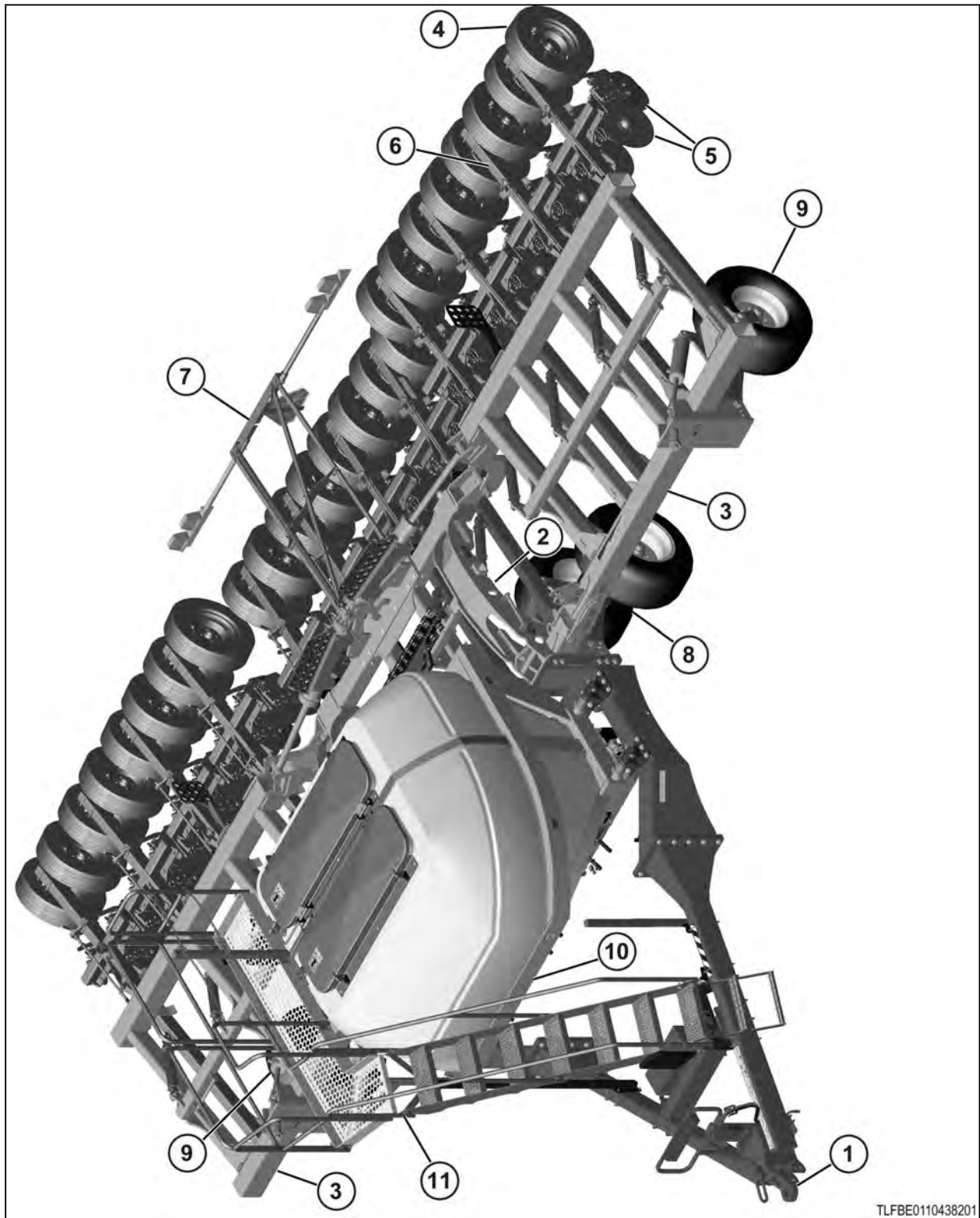

Fig. 3

2.4 Major components

The following are the major components of the machine.



TLFBE0110438201

Fig. 4

- | | |
|------------------|---------------------------------|
| (1) Tongue | (5) Opening discs |
| (2) Center frame | (6) Toolbars |
| (3) Wing frame | (7) Marker lamp bar |
| (4) Packer tires | (8) Center frame support wheels |

(9) Wing frame support wheels
(10) Hopper - two compartment

(11) Ladder

2.5 Operator manual storage

The Operator Manual is located in the container (1) on the machine.

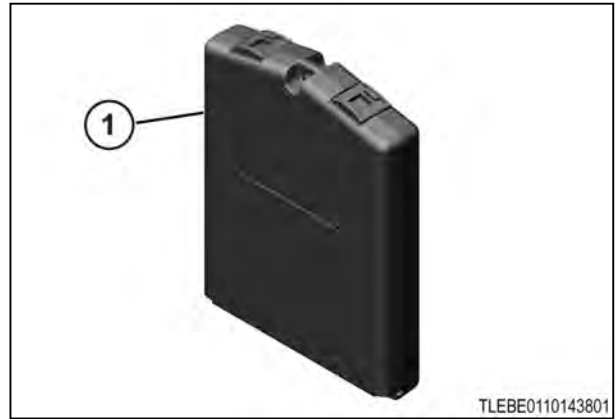

Fig. 5

3. Operation

3.1 Ladder and platform	51
3.2 Product hopper lids	52
3.3 Jack handle extension	53
3.4 ISOBUS Harness Connector	54
3.5 Connecting the machine to the tractor	55
3.6 Disconnecting the machine from the tractor	57
3.7 Hydraulic systems	60
3.7.1 Drill to tractor hydraulic couplers	60
3.7.2 Bleeding air from the hydraulic lift system	60
3.7.3 Bleeding air from the hydraulic fold system	61
3.8 Frame height cylinder phasing	63
3.8.1 Putting the frame height cylinders in phase	63
3.9 Blower	64
3.9.1 Blower speed	64
3.10 Meters	65
3.10.1 Changing the metering wheels	65
3.10.2 Meter latches	65
3.10.3 Cleanout tray latches	66
3.10.4 Meter shaft adjustment	66
3.11 Plenum operation	67
3.11.1 Lowering the plenum for service and calibration	67
3.11.2 Cleaning out the plenum	67
3.12 Wireless blockage monitor	68
3.13 Preparing the machine for transport	69
3.14 Preparing the machine for seeding	70
3.15 Leveling the wings to the center frame	72
3.16 Adjusting the cast boot	73
3.17 Opening disc offset	74
3.17.1 Setting opening disc offset	75
3.18 Packing tires	76
3.19 Seed depth	77
3.19.1 Checking the seed depth	77
3.19.2 Seed depth collar sequences	78
3.19.3 Initial seed depth collar sequences	79
3.19.4 Adjusting seed depth	79
3.20 Toolbar down pressure	80
3.21 Turning at the edge of a field	81
3.22 Software information	82
3.22.1 Software icon descriptions	82
3.22.2 Main work screen	83
3.23 System information	86
3.23.1 Terminal information	86
3.23.2 Implement software identification	86
3.23.3 Master switch	86
3.23.3.1 External master switch	87
3.23.3.2 Terminal master switch	87
3.23.4 Virtual switch box	87

3.24 Implement setup	89
3.24.1 Changing the implement settings	89
3.24.2 Calibrate a drill section	89
3.24.3 Setting the down pressure	90
3.24.4 Setting the product rate	91
3.24.5 Loading the bins	92
3.25 Totals	93
3.26 Maintenance	94

3.1 Ladder and platform

The machine has a ladder that folds up and down for easy access to the hopper lids.

The machine has a platform with handrails around to prevent falls.

NOTE: *Do not remove the handrails.*

Only fold the ladder when the machine is stopped and on a flat, solid surface.

Put the ladder (1) in the down position for access to the hopper lids.

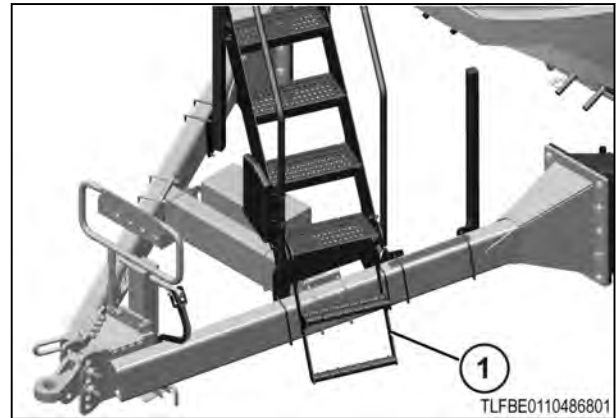

Fig. 1

Fold the ladder (1) to the storage position before transport or operation.

NOTE: *If the ladder is down in transport or operation, it can catch the tire and cause tire and ladder damage.*

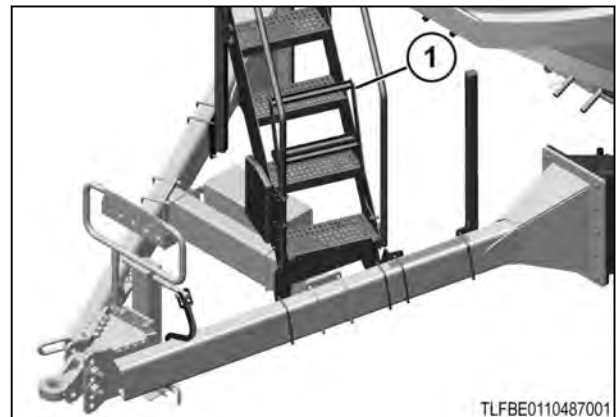

Fig. 2

3.2 Product hopper lids

The product hopper lids on the drill must be sealed to keep water out.

To open the latch, grab the end of the rod (1) and pull on the latch.

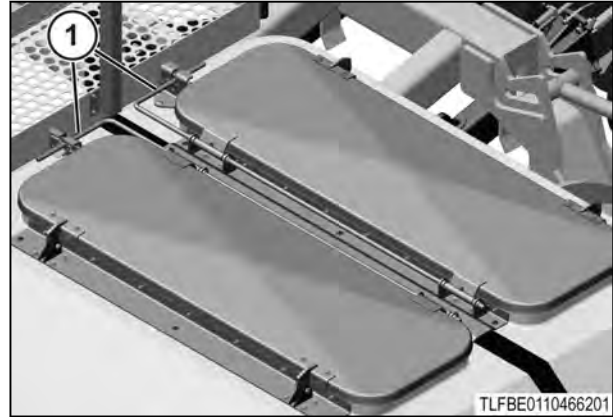

Fig. 3

Check the product hopper lids for correct adjustment and inspect the seal for damage.

To adjust the latch, loosen the four 1/4 inch bolts (1) that hold the latch, and move it up or down. The latch should be adjusted so there is slight pressure on the rod when it is secured. Tighten the four 1/4 inch bolts when finished.

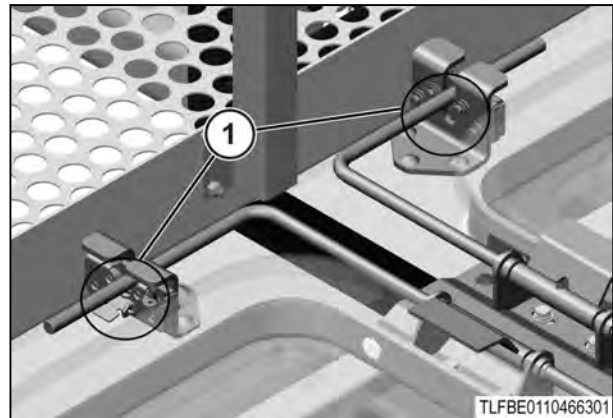

Fig. 4

3.3 Jack handle extension

The machine has an extension for the jack handle that is necessary to clear the drawbar.

Fold the jack handle extension (1) behind the drawbar when in transport or operation.

NOTE: *If the handle is not folded behind the drawbar, it can catch the tire and cause tire and jack damage.*

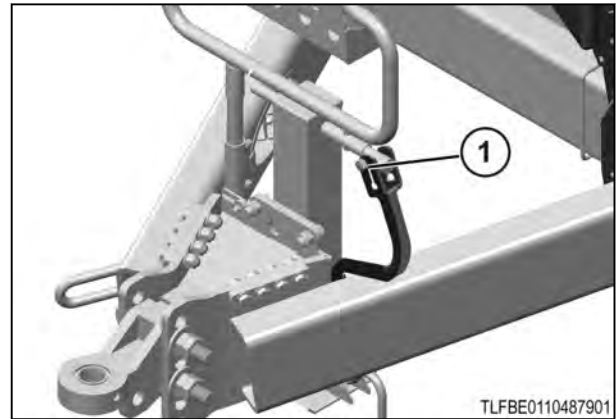

Fig. 5

3.4 ISOBUS Harness Connector

The machine has two connectors used to connect to the ISOBUS harness.

Front ISOBUS Connector

The front ISOBUS connector is located on the front hitch of the machine and is used to connect the machine ISOBUS to the tractor. The front ISOBUS connector is a standard nine pin connector.

Rear ISOBUS Connector

The rear ISOBUS connector (1) is located in the rear connection bulkhead and is used to connect the machine ISOBUS to a pull behind implement. The rear ISOBUS connector is a standard nine pin connector.

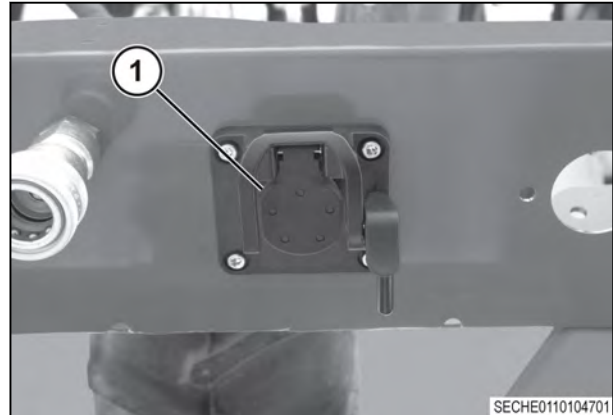

Fig. 6

3.5 Connecting the machine to the tractor

Procedure

1. Make sure there are no people, pets, or obstructions between the tractor and the machine.
2. Use the hitch jack (1) on the front hitch of the machine to adjust the height of the hitch. Adjust the height of the hitch on the machine until the hitch on the machine is at the same height as the hitch on the tractor.
3. Slowly move the tractor toward the hitch of the machine. Align the hitch on the tractor with the hitch on the machine when backing.
4. Stop the tractor when the hole of the tractor hitch aligns with the hole in the machine hitch.
5. Stop the engine, set the park brake, and take the ignition key with you.
6. Install the hitch pin (1) through the holes in the tractor draw bar (2) and machine hitch (3). Install the keeper pin (4) in the hitch pin.
7. Connect the safety chains from the front hitch of the machine to the tractor.

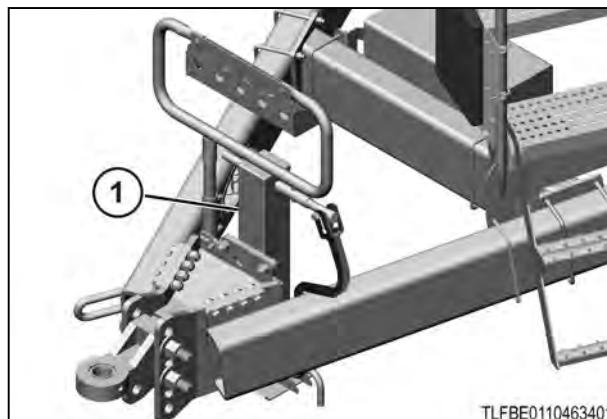

Fig. 7

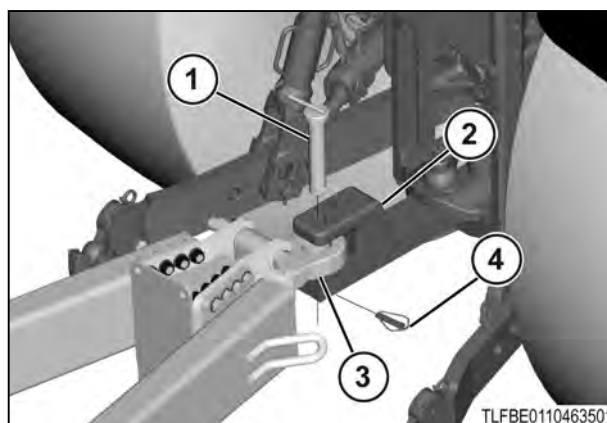

Fig. 8

8. Retract the hitch jack (1).
9. Clean the ends of the hydraulic connections on the machine and the tractor.
10. Make the following connections between the tractor and the machine.
 - Lift cylinder hydraulic hoses
 - Wing cylinder hydraulic hoses
 - Toolbar down pressure hydraulic hoses
 - Fan hydraulic hoses
 - ISO harness to the tractor
 - Safety light harness

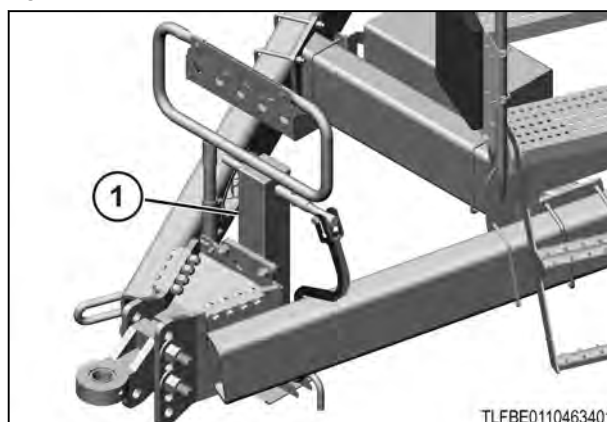

Fig. 9

IMPORTANT: Connect the toolbar down pressure hydraulic hoses and wing cylinder hydraulic hoses directly to the tractor hydraulics. Aftermarket or added hydraulic connections do not supply the needed hydraulic flow to operate the machine correctly.

11. Start the tractor and use the tractor hydraulics to lift the frame of the machine to the highest position.

12. If the wing frames were down during storage, make sure the wing cylinders are connected to the wing frames.
13. Use the tractor hydraulics to fully lift the wing frames of the machine.
14. Stop the engine, set the park brake, and take the ignition key with you.
15. Remove the wheel chocks (1) or blocks from in front of and behind the frame support tires (2).
16. Make sure all people, pets, and obstructions are clear before moving the tractor and machine.

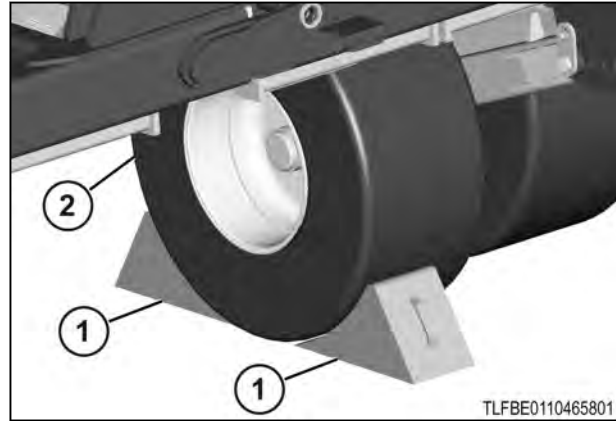

Fig. 10

3.6 Disconnecting the machine from the tractor

NOTE: Lower the wings for storage when possible.

Procedure

1. Park the tractor and machine on a solid level surface.
2. Stop the engine, set the park brake, and take the ignition key with you.
3. Use the tractor hydraulics to lower the wings to the ground if possible.
4. Use the tractor hydraulics to fully lift the toolbars.
5. Stop the engine, set the tractor park brake, and take the ignition key with you.
6. When disconnecting the machine with the wing frames lifted, install the wing lock pins (1) and wire lock pins (2) in the wing lock brackets (3).

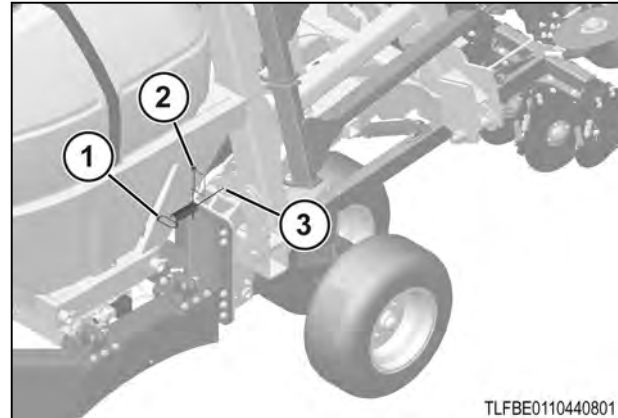

Fig. 11

7. Use the toolbar locks (1) to lock the toolbars in the locked position (2).

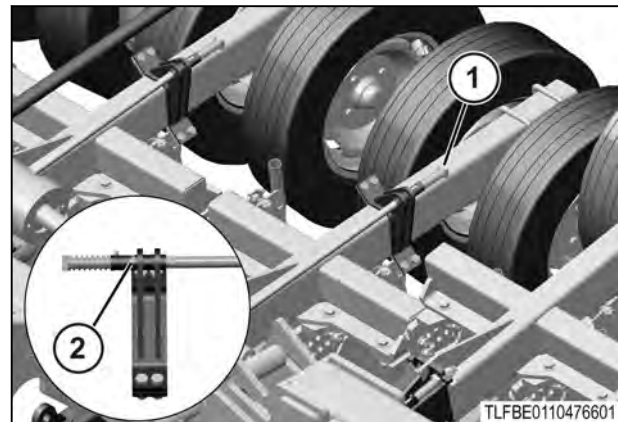

Fig. 12

8. Install wheel chocks (1) or blocks in front of and behind each of the frame support tires (2).

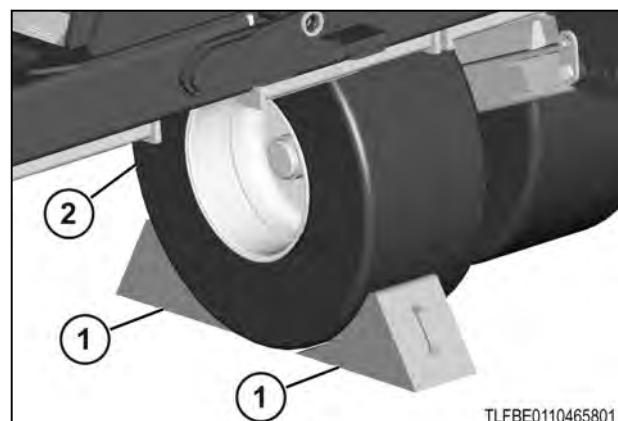

Fig. 13

9. Remove all the seed depth collars (1) from the frame height cylinders (2) and place them on the depth collar storage bracket.
10. Start the tractor. Lower the frame of the machine until the weight of the machine is off of the hitch of the tractor.

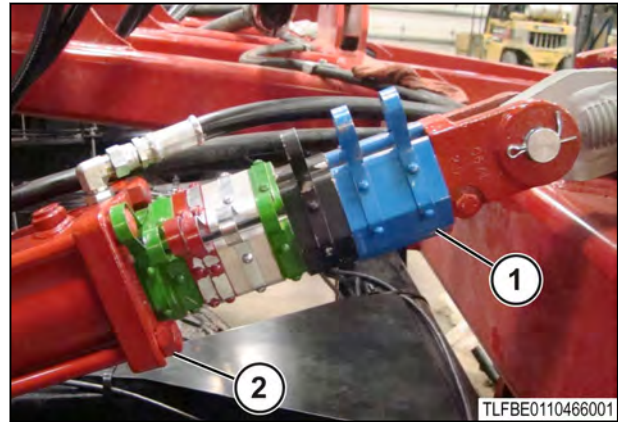

Fig. 14

11. Stop the engine, set the tractor park brake, and take the ignition key with you.
12. Install the correct seed depth collars on the frame height cylinders to take up the remaining stroke of each frame height cylinder.
13. Start the tractor. Continue to lower the frame of the machine until the seed depth collars support the weight of the frame.
14. Use the hitch jack (1) to support the front hitch of the machine.
15. Disconnect the following connections from the tractor.
 - Lift cylinder hydraulic hoses
 - Wing cylinder hydraulic hoses
 - Down pressure hydraulic hoses
 - Fan hydraulic hoses
 - ISO harness to the tractor
 - Light harness

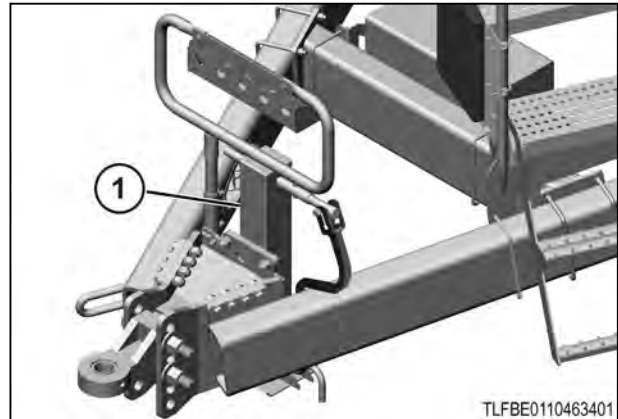

Fig. 15

16. Install each of the hydraulic hose connections (1) in the hose support bracket (2).
17. Clean the hydraulic connections between the machine and the tractor of any dirt or hydraulic fluid.
18. Remove the transport safety chains from the tractor.

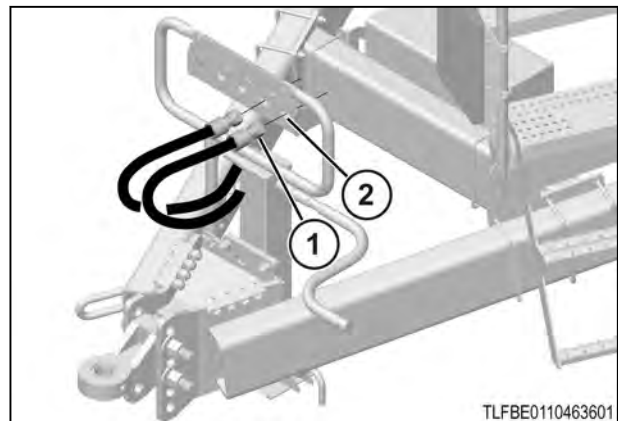

Fig. 16

19. Remove the keeper pin (1) from the hitch pin (2). Remove the hitch pin from the hitch (3) and draw bar (4).

IMPORTANT: *Make sure there are no connections between the tractor and the machine.*

20. Make sure all people and pets are clear of the tractor and machine.
21. Slowly move the tractor away from the machine.

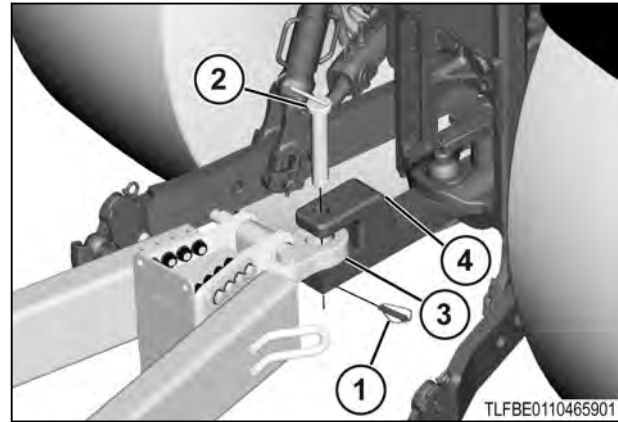

Fig. 17

3.7 Hydraulic systems

The hydraulic system on the machine includes:

- Blower control circuit
- Downpressure circuit
- Wing fold circuit
- Depth control circuit

This system was designed to function under a maximum hydraulic pressure of 19 995 kPa (2900 psi).

Fan only	10cc fan motor	
Fan speed	Flow	Pressure
3000 rpm	30.3 l/min (8 gal/min)	6895 to 10 342 kPa (1000 to 1500 psi)
4000 rpm	39.7 l/min (10.5 gal/min)	9653 to 13 100 kPa (1400 to 1900 psi)
5000 rpm	51 l/min (13.5 gal/min)	12 411 to 15 858 kPa (1800 to 2300 psi)
6000 rpm	60.6 l/min (16 gal/min)	15 168 to 18 616 kPa (2200 to 2700 psi)

3.7.1 Drill to tractor hydraulic couplers

The couplers connecting the blower pressure and the return lines from the drill to the tractor are (1/2 inch) #10 ISO 5675 (Pioneer) tip couplers.

A (3/8 inch) #8 ISO 16028 (flat-face) coupler tip on the drill connects the case drain line to the tractor. The case drain line must be connected or the blower motor will be damaged. If a case drain return port is not available on your tractor, contact your dealer.

A (3/4 inch) #12 ISO 7241-1 Series A low-pressure return tip is included with all implements. The low-pressure return tip is also available through Service Parts.

If your tractor has a low-pressure port available, the low-pressure return tip can be used on the 3/4 inch blower return line. Using the low-pressure return tip can remove the pressure drop caused by the 1/2 inch Pioneer tip and the hydraulic valve of the tractor on the return side. The low-pressure return tip can also be used on the case drain line, if the 3/8 inch flat face port is not available.

Do not install a tee fitting connecting the blower return line and the blower case drain lines together. The blower case line must always be connected to a direct return to the hydraulic reservoir or blower motor failure will result.

The hydraulic line with the label pressure must be used to operate the blower. A check valve is installed in the blower circuit to protect the motor from the too much pressure in the return line and prevents cavitation during shutdown.

The couplers connecting the downpressure, wing fold and depth control circuits from the drill to the tractor are (1/2 inch) #10 ISO 5675 (Pioneer) tip couplers.

3.7.2 Bleeding air from the hydraulic lift system

Before starting the procedure



WARNING:

Leaking fluid under pressure can enter the skin causing serious injury. Release pressure before disconnecting hydraulic or other lines. Tighten all connections before applying pressure. Keep hands and body away from pinholes and nozzles which eject fluids under high pressure. Wear correct hand and correct eye protection when looking for leaks. Use a piece of cardboard or paper instead of your hand. Any fluid injected into the skin can cause gangrene. The fluid must be removed by a doctor familiar with this type of injury.

WARNING:

Be careful of sweeps or blades when folded to prevent serious injury. Never keep the machine with the wings in the folded position.

To bleed the air from the hydraulic lift system, connect the machine to a tractor that is the correct size to operate the machine. See the information for minimum tow vehicle weight.

Completely bleed the hydraulic system of air when:

The lift system is filled with hydraulic oil for the first time.

Air has entered the hydraulic system through a leak or through repair of the hydraulic system.

Procedure

1. Park the machine on a flat, level surface that is large enough for the machine when unfolded.
2. Set the tractor hydraulic flow to less than 75.7 L/min (20 gal/min).
IMPORTANT: *If the hydraulic flow is set to more than 75.7 L/min (20 gal/min) the hydraulics will not operate correctly.*
3. Connect the lift system hoses to the tractor.
4. Make sure the tractor reservoir is full of the hydraulic oil required by the manufacturer.
IMPORTANT: *Do not loosen any hydraulic fittings to bleed air from the system.*
5. Raise the machine. Continue to hold the tractor lever to let oil bypass and fill each wing lift cylinder.
6. Engage the hydraulics to remove any hydraulic transport locks if equipped.
7. Stop the engine, apply the park brake and take the key with you.
8. Remove the transport locks when all lift cylinders are fully extended.
9. Lower the unit.
 Make sure the cylinders move at the same time through the cycle.
10. Hold the hydraulic lever with the cylinders fully extended.
11. If the cylinders are not operating together, cycle the cylinders to remove the remaining air.
IMPORTANT: *Do not loosen any hydraulic fittings to bleed air from the system.*
12. Stop the engine, apply the park brake, and take the key with you.
13. Check the tractor hydraulic oil reservoir to make sure the hydraulic oil is still within operating limits.
14. Make sure all lift cylinders are operating together before starting any field operation.
15. Fully raise the machine when making turns during field operation.
 This will make sure that the cylinders are operating together and keep the machine level during operation.

3.7.3 Bleeding air from the hydraulic fold system

Before starting the procedure

WARNING:

Leaking fluid under pressure can enter the skin causing serious injury. Release pressure before disconnecting hydraulic or other lines. Tighten all connections before applying pressure. Keep hands and body away from pinholes and nozzles which eject fluids under high pressure. Wear correct hand and correct eye protection when looking for leaks. Use a piece of cardboard or paper instead of your hand. Any fluid injected into the skin can cause gangrene. The fluid must be removed by a doctor familiar with this type of injury.

**WARNING:**

Be careful of sweeps or blades when folded to prevent serious injury. Never keep the machine with the wings in the folded position.

IMPORTANT: Do not fold or unfold the fold system before bleeding air from the fold system.

To bleed the air from the hydraulic fold system, connect the machine to a tractor that is the correct size to operate the machine. See the information for minimum tow vehicle weight.

Completely bleed the hydraulic system of air when:

The fold system is filled with hydraulic oil for the first time.

Air has entered the hydraulic system through a leak or through repair of the hydraulic system.

Procedure

1. Set the tractor hydraulic flow to less than 75.7 L/min (20 gal/min).

IMPORTANT: If the hydraulic flow is set to more than 75.7 L/min (20 gal/min), the hydraulics will not operate correctly.

NOTE: Restrictors are installed in the fold cylinders to prevent falling of the wings. Never remove the restrictors, or the machine will not fold correctly.

2. Stop the engine, apply the park brake, and take the key with you.
3. Connect the fold system hoses to the tractor.
4. Make sure the tractor reservoir is full of the hydraulic oil required by the manufacturer.
IMPORTANT: Do not loosen any hydraulic fittings to bleed air from the system.
5. Remove the pins from the rod ends of the fold cylinders.
6. Make sure the rod ends of the fold cylinders will not come into contact with any obstructions. If a blockage is present, lift the rod ends of the fold cylinders.
7. Use the remote lever in the tractor to fully extend and retract the fold cylinders. Extend and retract multiple times.
8. If the fold cylinders are not operating together, cycle the fold cylinders to remove the remaining air.
IMPORTANT: Do not loosen any hydraulic fittings to bleed air from the system.
9. Stop the engine, apply the park brake, and take the key with you.
10. Check the tractor hydraulic oil reservoir to make sure the hydraulic oil reservoir is still within operating limits.
11. Connect the rod ends of the fold cylinders to the machine.
12. Find an area large enough for the machine when unfolded.
13. Park the machine on a solid, level surface. Stop the engine, apply the park brake, and take the key with you.
14. With the tractor at a low idle, slowly engage the hydraulics to fold and unfold the machine.
15. Fully extend the fold cylinders to let the wings flex freely.

3.8 Frame height cylinder phasing

When the support cylinders extend to the same length at the same time the support cylinders are in phase. If the cylinders do not extend to the same length at the same time then the cylinders must be put in phase.

Frame height cylinders that are out of phase will cause the machine to not be level with the ground when lifting or lowering the machine. A frame that is not level to the ground will cause different seed depth between each toolbar.

3.8.1 Putting the frame height cylinders in phase

Before starting the procedure

To put the frame height cylinders in phase the machine must be connected to the correct size of tractor to operate the machine.

Putting the frame height cylinders in phase makes sure the cylinders are moving to the same length at the same time.

Procedure

1. Lift the frame of the machine to the highest position.
2. Hold the hydraulic lever in the raised position for five seconds.

After finishing the procedure

Make sure the frame height cylinders are phased by lowering the machine to the ground and raising the machine to half of the fully raised height. If the frame is level to the ground then the cylinders are in phase.

3.9 Blower

The blower system for the machine generates air pressure/flow to carry the seed or other input products through the system to the implement. A hydraulic motor drives the blower system. Two 3/4 inch hydraulic lines supply oil to the blower.

The only part on the blower that can be serviced is the shaft seal. The shaft seal can be replaced if the motor leaks at the shaft. Do not disassemble the motor to replace the shaft seal. The shaft seal is fastened by a snap ring and can be removed with a seal pick.

IMPORTANT:

Be sure that the case drain line on the blower motor is not connected to pressure. Damage to the shaft seal or motor will result.

IMPORTANT:

Do not under any circumstances disassemble the motor. The motor is very difficult to correctly assemble and motor destruction will result. If a motor failure occurs, get a replacement motor from the dealer.

3.9.1 Blower speed

Operate the blower at as slow a speed as possible to prevent damage to seed. If operated too slowly, line blockage will occur. Typical blower speeds are between 3000 and 6000 rpm. The drill width, product, rate, humidity, and other factors can change blower speed.

If a run blockage monitor is not used, make sure all runs are operating after changing blower speeds. To check the runs:

1. Turn the meter(s) with the blower running
2. Make sure there is product at each ground opener

The number of outlets on the implement will directly change the blower rpm. The more outlets in use, the higher the pressure required to keep blower rpm. See your dealer for hydraulic adjustments to your tractor, if necessary.

One method to determine blower RPM is to remove a final run from the seed boot or shoe. Hold the hose about 1.5 meter (5 ft) off of the ground pointing straight up. Turn product out of the meter with the blower running. The product coming from the hose must blow out of the hose approximately 203 mm (8 inches) into the air. Adjust blower RPM as required.

3.10 Meters

3.10.1 Changing the metering wheels

Procedure

1. Lower the plenum (1) and turn the tractor off.
2. Turn the welded hex nuts (2) to close the hopper gates (3) for the front and rear tanks.
3. Release the clean out tray latches (4).
4. Use the clean out tray handle (5) to open the clean out tray and remove any product.
5. Lower the meters by the two large over center latches (6) on each side of the meter.

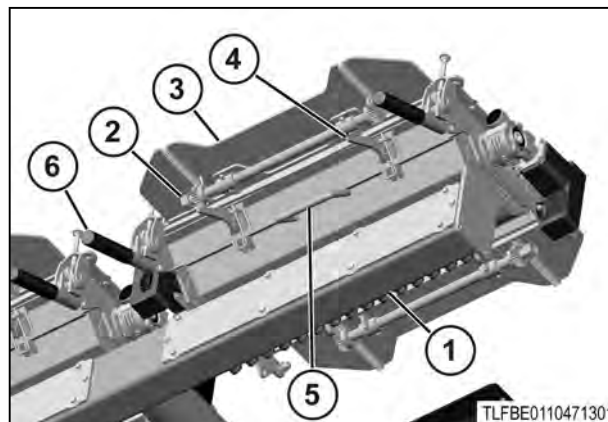

Fig. 18

6. Pull the hairpins (1) to remove the motors (2).

NOTE: The key may fall out when the motors are removed.

7. Remove the four 1/4 inch bolts (3) on the flange bearings (4).
8. Pull the shaft assembly straight out of the meter.
9. Remove the 5/8 inch lock collars (5) on one side.
10. Move the spacers (6) and metering wheels (7) off of the shaft.
11. Assemble the meter in the opposite order with the necessary metering wheels.

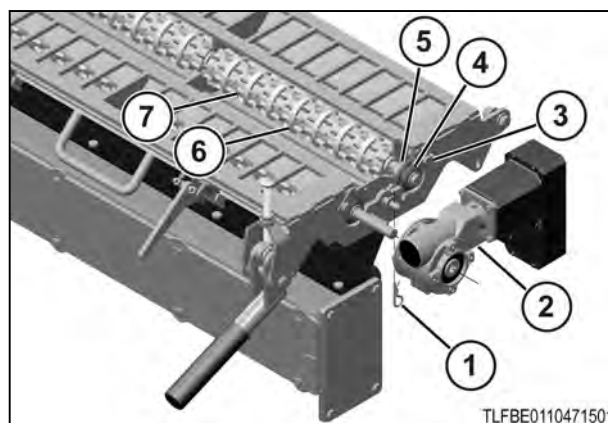

Fig. 19

3.10.2 Meter latches

The meter latches can be adjusted to let the meter close tight against the hopper shut off assembly where product does not leak out.

With the meter correctly adjusted, there should be no gap seen between the meter and the shut off assembly.

To adjust the meter to hopper shut off:

1. Loosen the jam nuts (1) and the two 3/8 inch carriage bolts (2) on the over center latches.
2. Extend or retract the carriage bolts until there is correct preload on the clamp. If the preload is too small the meter will not seal correctly. If too tight the clamp will not close.
3. If necessary, loosen the two 3/8 inch bolts (3) on the rear hinge of the meter. This will let the meter lift or lower at the hinge.

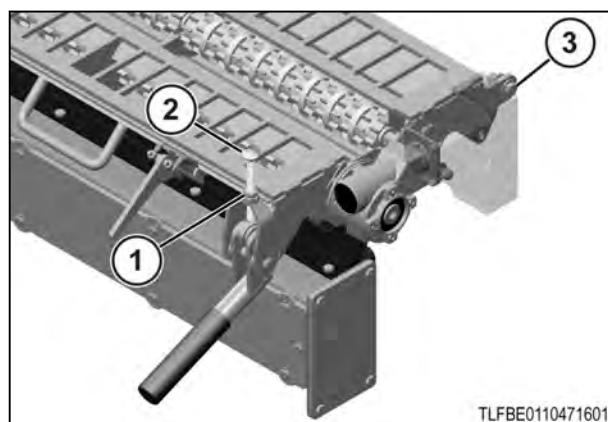

Fig. 20

3.10.3 Cleanout tray latches

The clean out tray latches (1) can be adjusted to increase or decrease the preload on the meter door. If the preload is too small, the tray will not seal correctly. If the tension is too tight, the latches will not easily close.

To adjust the clean out latches:

1. Unlock the clean out latch.
2. Turn the two stop-nuts (2) evenly in or out.
3. Lock the latch and make sure the preload is correct before operation.

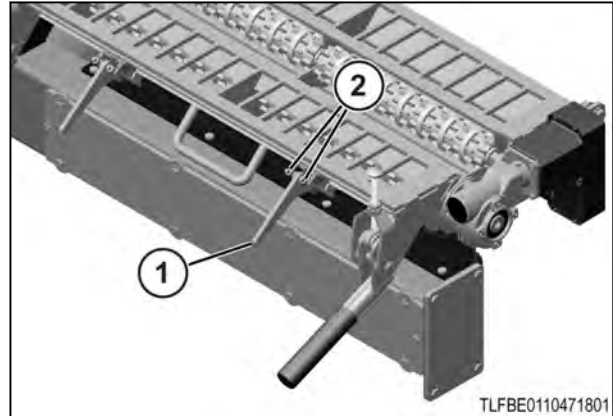

Fig. 21

3.10.4 Meter shaft adjustment

For larger products such as beans and peas, the meter shaft (1) must be lifted to let the products pass. The bearings (2) have slots for adjustment.

To lift the meter shaft:

1. Remove the hair pin (3) and remove the motor (4).

NOTE: The key may fall out when the motors are removed.

2. Loosen the four 1/4 inch bolts (5) that hold the bearings to the meter.
3. Move the assembly up or down as necessary.
4. Make sure each end of the shaft assembly is at approximately the same height for the most accurate metering.
5. Tighten the four 1/4 inch bolts that hold the bearings to the meter.

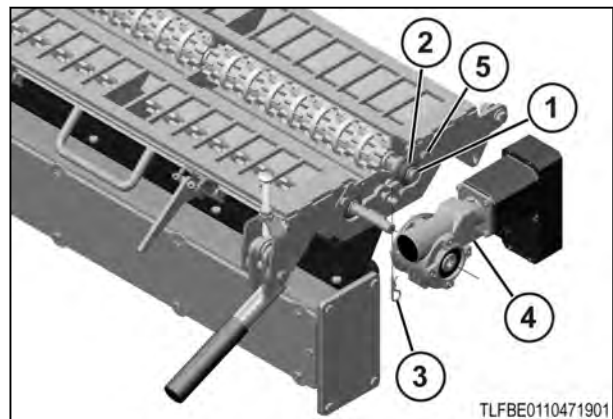

Fig. 22

3.11 Plenum operation

The plenum supplies the air from the blower to all the venturi cups. Make sure that the plenum is fully lifted and sealed against the seed hose bulkhead and fans before operation, transport and storage. The plenum is locked with a hydraulic valve.

3.11.1 Lowering the plenum for service and calibration

The plenum must be lowered for calibration and service. This is done with a hydraulic valve on the inside of the hopper frame. The valve is connected to the blower hydraulic circuit.

Procedure

1. Start the blower circuit hydraulic remote.
2. Make sure that the fan is turned off with the keypad or terminal.

NOTE: Do not remove the cylinder stop on the hydraulic cylinder or damage to the plenum can occur.

3. Push the valve lever (1) down to lower the plenum.
4. Push the valve lever up to lift the plenum.

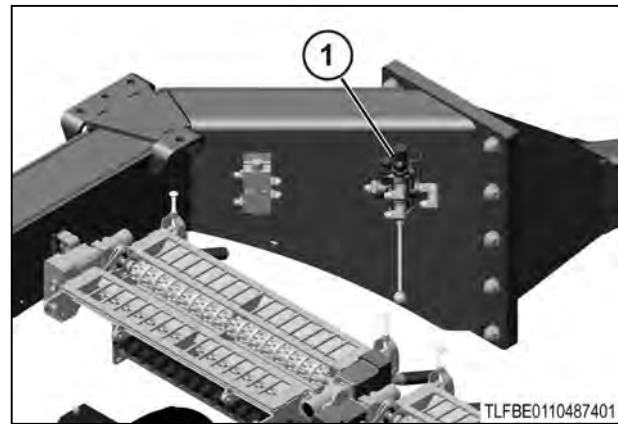

Fig. 23

3.11.2 Cleaning out the plenum

During operation, product can enter the plenum at the venturi. If this product collects in the plenum it can cause blockage and the plenum must be cleaned out.

Procedure

1. Remove the four hex bolts (1) that attach each of the two access panels (2).
2. Remove the two access panels .
3. Clean out the collected product.
4. Install the two access panels and attach each panel with four hex bolts.

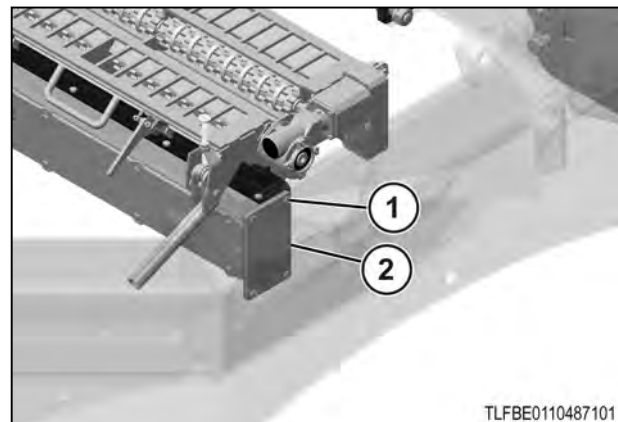

Fig. 24

3.12 Wireless blockage monitor

The wireless blockage monitor system uses inline sensors on each seed run to sense blockage or plugs. The ECU connects wirelessly with an iPad in the cab. A wifi terminal (included with the machine) is necessary in the cab for communication.

The app must be downloaded onto the iPad, which can be found on the iPad App Store. Search the app store for "wireless blockage monitor". Follow the instructions for setting up the blockage configuration. From this app, the user can see the newest blockage monitor manual. It can also be found online at www.intelligentag.com/support/.

3.13 Preparing the machine for transport

Before starting the procedure

Stop the tractor before preparing the machine for transport. Remove the remaining seed from the hopper before transporting.

Procedure

1. Use the tractor hydraulics to lift the frame of the machine to the highest position.
2. Use the tractor hydraulics to fully lift the toolbars of the machine.
3. Use the tractor hydraulics to fully lift the wings of the machine.
4. Stop the engine, apply the tractor park brake, and take the ignition key with you.
5. Move the handle of the toolbar lock-out (1) to the closed position.

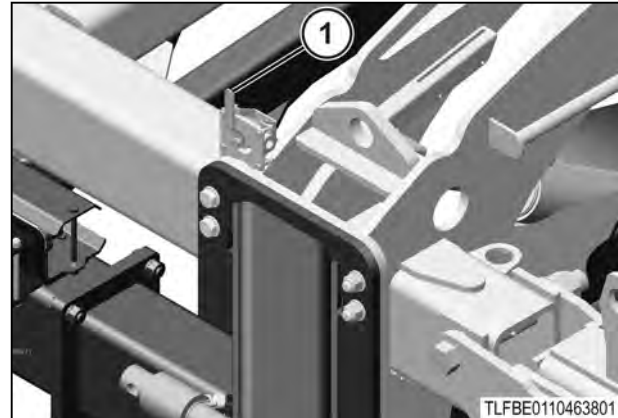

Fig. 25

6. Lock the wings in the raised position by installing the wing lock pins (1) and wire lock pins (2) in the wing lock brackets (3).

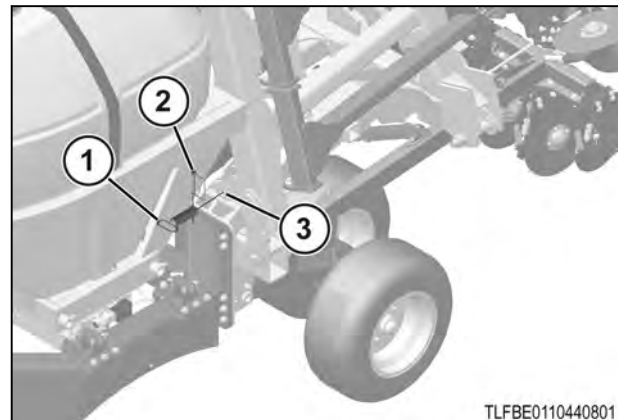

Fig. 26

7. Lock the toolbars in the raised position by moving the toolbar locks (1) to the locked position (2).
8. Install the transport locks and lower the frame onto the locks.
9. Make sure the rear facing lamps and reflectors are free of dust and operate correctly.

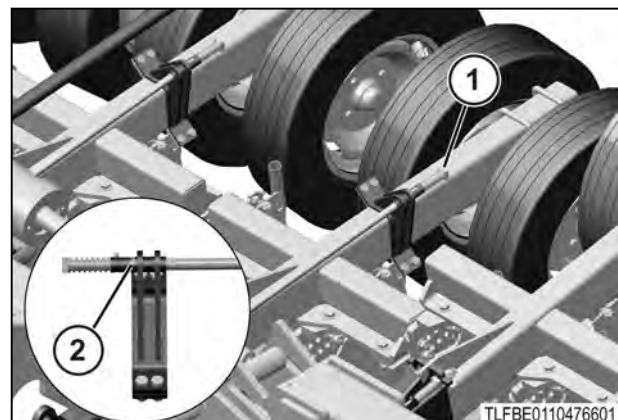

Fig. 27

3.14 Preparing the machine for seeding

Before starting the procedure

The machine must be connected to a tractor that is the correct size to operate the machine. See the information for the minimum tow vehicle weight.

Make sure there is enough area around the machine to completely lower the wings.

Procedure

1. Stop the tractor. Stop the engine, apply the tractor park brake, and take the ignition key with you.
2. Make sure the area below the machine is clear of people, pets, and obstructions.
3. Move the toolbar lock-out handle (1) to the open position.
4. Start the tractor.
5. Use the tractor hydraulics to remove any load from the toolbar locks by fully lift the toolbars.
6. Use the tractor hydraulics to remove any load from the wing lock pins by fully lift the wings.
7. Stop the engine and take the ignition key with you.
8. Remove the wing lock pins (1) and wire lock pins (2) from the wing lock brackets (3). Install the wing lock pins in the storage brackets on the frame.
9. Start the tractor.
10. Use the tractor hydraulics to lower the wings to the operating position.
11. Move all the toolbar locks (1) to the unlocked position (2).
12. Use the tractor hydraulics to lower the toolbars and move the hydraulic lever to full down position.
13. Use the terminal to set the initial down pressure.
14. Stop the engine and take the ignition key with you.

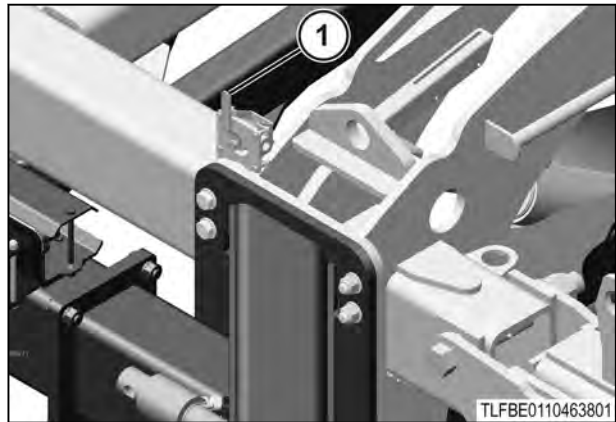

Fig. 28

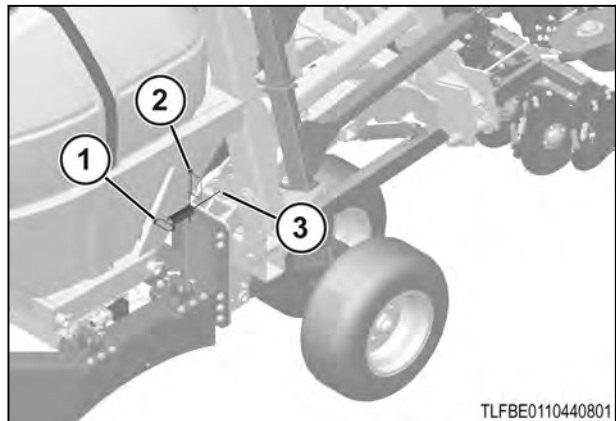

Fig. 29

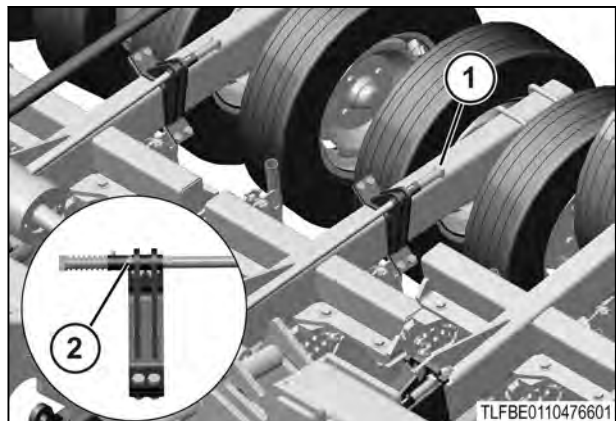

Fig. 30

15. Install the initial sequence of seed depth collars (1) on the shafts of the frame height cylinders (2).
16. Check the seed depth and the down pressure of the machine. Make the needed adjustments.

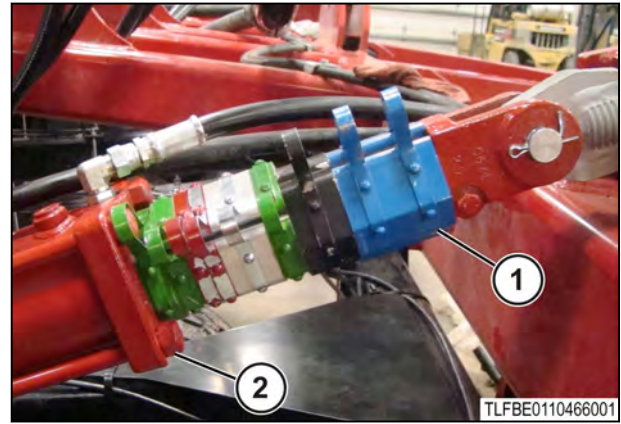

Fig. 31

3.15 Leveling the wings to the center frame

Use this procedure to level the wings to the center frame.

Before starting the procedure



WARNING:

Avoidance hazard. Clearance. Serious personal injury can occur. Make sure all persons are clear of the area before operating the machine.

The machine must be connected to a tractor that is the correct size for operation. See the specifications section for more information.

Make sure there is area around the machine to fully lower the wings.

Procedure

1. Park the drill on a flat and level surface.
2. Stop the engine, apply the park brake, and take the key with you.
3. Lift the drill to the highest position and then hold the hydraulic lever in the raised position for five seconds.

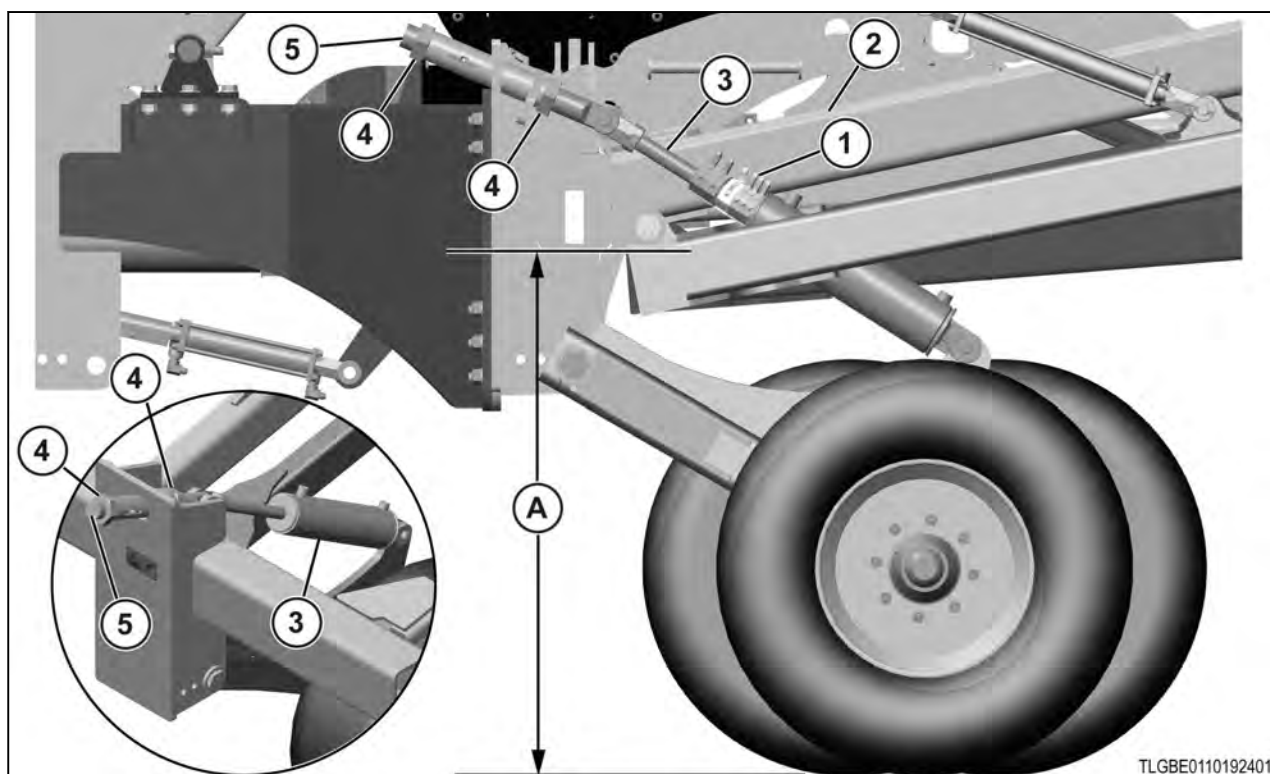

Fig. 32

4. Install the cylinder stop collars (1) on the lift cylinders to approximate operating height.
5. Make sure all four lift cylinders have the same stop collars installed.
6. Lower the drill frame until the weight of the machine is held by the cylinder stop collars.
7. Measure the distance (A) from the ground to the bottom of the frame (2). Measure in front of each of the frame and the wing support cylinders (3).
8. Adjust the adjusting rods (5) above each of the wing support cylinders (3). Adjust the adjusting rod until the measurement between the frame and the ground is the same. Adjust the adjusting rods by tightening or loosening the jam nut (4) on either end of the adjusting rod.
9. Make sure the measurement at each of the wing support cylinders is equal. Tighten the jam nuts against the tube that holds the adjustment rod.

3.16 Adjusting the cast boot

If the cast boot goes out of adjustment, follow these steps to adjust.

Procedure

1. Loosen the two 1/2 inch hex bolts (1) that hold the pivot pin.
2. Push on the top of the boot until the front edge of the boot evenly rides on the disc .
3. Tighten the two 1/2 inch hex bolts.

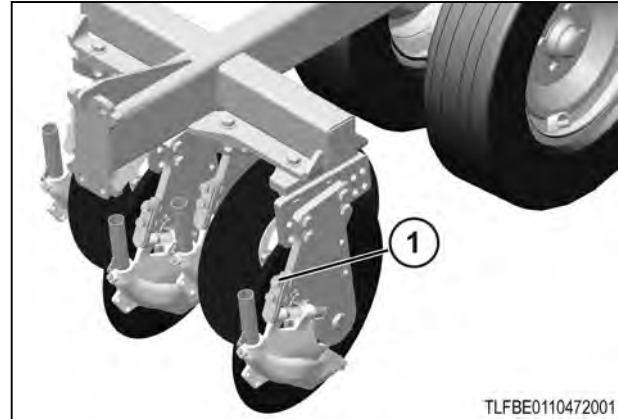

Fig. 33

3.17 Opening disc offset

The opening disc offset is the amount of offset (A) between the two opening discs (1) on each toolbar. The opening disc offset prevents material from accumulating between the two opening discs on the opening disc assembly.

The opening disc offset is set at 114 mm (4.5 inch) at the factory, but can be adjusted from 38 mm (1.5 to 6.5 inch).

Increase the opening disc offset for wet, sticky soils.

Decrease the opening disc offset for dry, sandy soils.

If operating in soil with large rocks, set the opening disc offset to the maximum offset.

If the opening disc offset is too wide, there will not be enough soil movement for sufficient trench closure.

If the opening disc offset is too narrow, material will build between the two opening discs.

Use the five sets of holes on one side (1) of the opener mount to adjust one of the opening discs. Use the two sets of holes on the opposite side (2) to adjust the other opening disc offset. Each set of holes will change the offset by 25 mm (1 inch) (A).

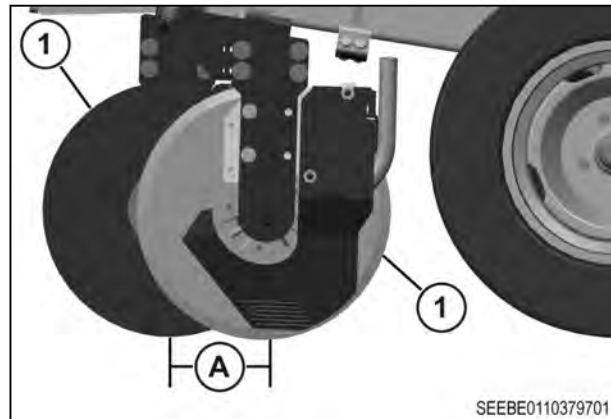

Fig. 34

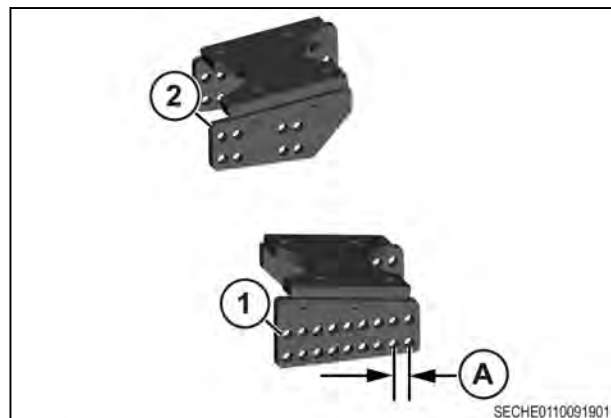

Fig. 35

Opening disc offset table

The following table shows the opening disc offset according to the position of the opening disc struts (1) on the opening disc mount (2). The first column shows the number of pairs of holes (3) forward of the opening disc strut on the five position side of the opener mount. The second column shows the position of the opening disc strut on the two position side of the opener mount, forward or rear. The third column shows the opening disc offset.

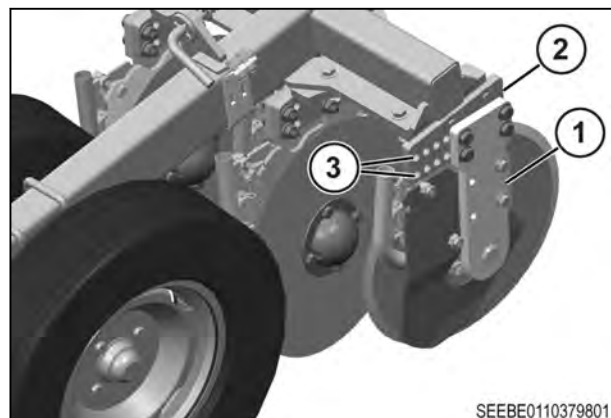

Fig. 36

Number of Pairs of Holes Forward of the Opening Disc Strut	Position of the Opening Disc Strut	Opening Disc Offset
0	Rear	165.1 mm (6.5 inch)
0	Forward	139.7 mm (5.5 inch)
1	Forward	114.3 mm (4.5 inch)
2	Forward	88.9 mm (3.5 inch)
3	Forward	63.5 mm (2.5 inch)
4	Forward	38.1 mm (1.5 inch)

3.17.1 Setting opening disc offset

The opening disc offset is adjusted according to field conditions.

Procedure

1. Lift the frame of the implement to the highest position.
2. Stop the tractor. Stop the engine, apply the tractor park brake, and take the ignition key with you.
3. Support the opening disc strut (1) and opening disc (2).
4. Remove and keep the four bolts, washers, and lock nuts attaching the opening disc strut to the opener mount (3).
5. Move the opening disc strut to the new position of the opener mount.
6. Attach the opening disc strut to the opener mount with the existing bolts, washers, and lock nuts.

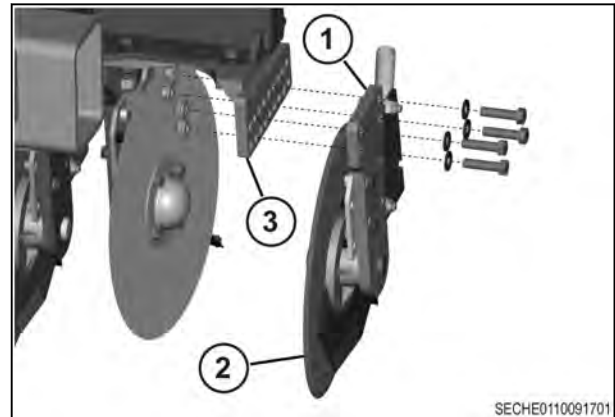

Fig. 37

After finishing the procedure

Move the remaining opening disc struts to the new position on the opener mounts on the remaining opening disc assemblies.

3.18 Packing tires

The packing tires (1) located behind the opening disc assemblies (2) close the two furrows made by each of the opening discs.

The packing tires operate at an angle to the travel of the drill. The angle closes the two furrows and removes any accumulated mud from the tires when operating in wet soil conditions. The packing tires on the right-hand side of the drill are angled toward the center of the drill. The packing tires on the left-hand side of the drill are angled toward the center.

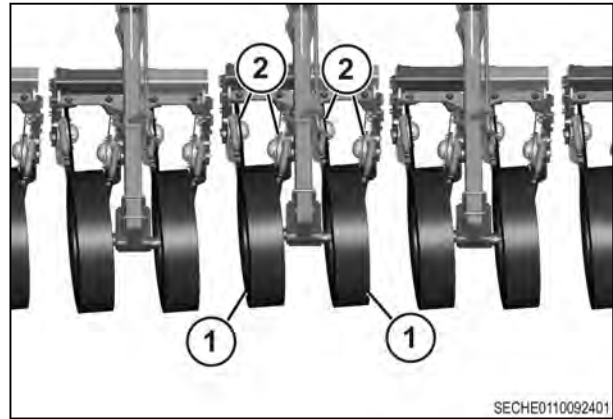

Fig. 38

3.19 Seed depth

Seed depth is how deep the drill plants the seed in the ground. The seed depth changes in relationship to how close the frame of the drill is to the ground; the closer the frame is to the ground; the deeper the drill plants the seed.

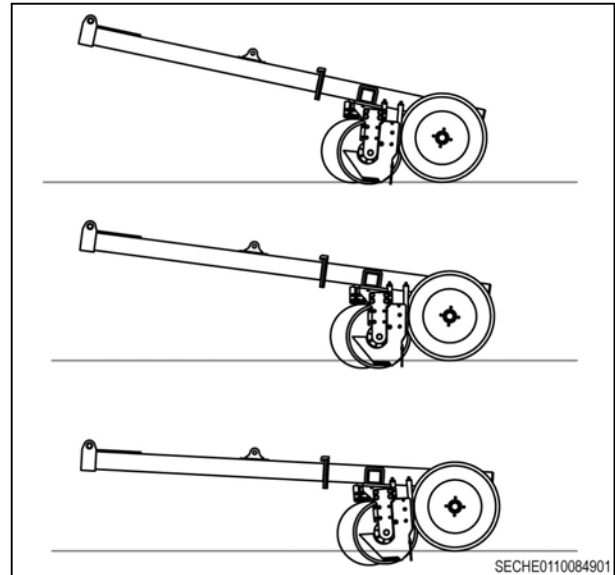

Fig. 39

Adjust the seed depth by installing seed depth collars (1) on the shafts of the frame height cylinders (2). Install the same sequence of depth collars on each frame height cylinder.

There are four different widths of depth collars. The color of the depth collar identifies the width of the depth collar. The following is the color and width of each depth collar.

- Blue = 7.62 cm (3.0 inch)
- Silver = 3.81 cm (1.5 inch)
- Green = 1.91 cm (0.75 inch)
- Red = 1.27 cm (0.50 inch)

Different sequences of depth collars will cause different seed depths. Use the best sequence of depth collars for the field conditions.

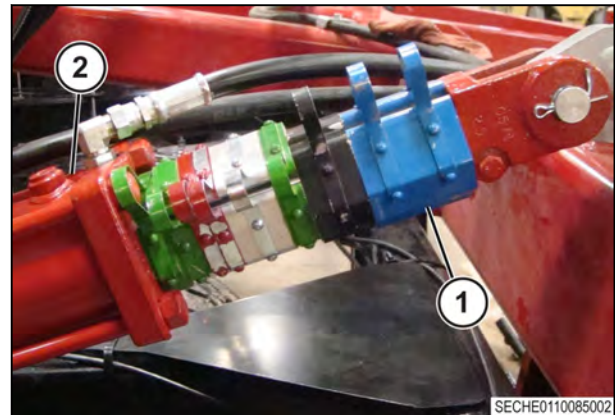

Fig. 40

3.19.1 Checking the seed depth

Check the seed depth in the field before seeding with the machine.

Procedure

1. Connect the machine to a tractor of the correct size to operate the machine.
2. Set the seed depth of the machine by installing the initial sequence of the seed depth collars.
3. Fill the seed hopper or seed container with seed.
4. Put all the components of the machine in the field position.
5. Lower the machine and plant a straight section at the needed speed for approximately 55 m (30 yd).
6. Stop the tractor. Stop the engine, apply the tractor park brake, and take the ignition key with you. Find one of the furrows behind the machine.

7. Carefully remove the soil covering four of the planted seeds.



Fig. 41

8. Measure the distance from the surface of the soil to the bottom of each seed. Use one of the following two methods.
 - **Using a ruler and a straight edge:** Place the straight edge flat against the surface of the ground. Hold a ruler vertically in the seed furrow next to the seed. Measure the distance from the bottom of the seed to the bottom of the straight edge.
 - **Using the seed finding tool:** Place the long flat section (1) of the seed finding tool against the ground with the short flat section (2) inside the seed furrow (3). Press the short flat section in the ground until the long flat section is flush with the ground. Measure the depth of the furrow using the marks on the short flat section.



Fig. 42

Result

The measurement taken is the actual seed depth.

9. Check the depth of the seeds in two of the other furrows behind the machine.
10. Compare the measurements to the correct seed depth and adjust the machine as necessary.

After finishing the procedure

Continue to check the seed depth until the machine plants the seed at the correct seed depth.

3.19.2 Seed depth collar sequences

Each letter in the following chart represents the color of the depth collar.

- B = Blue
- S = Silver
- G = Green
- R = Red

The two rows of numbers below the letters in the chart are the total length of the depth collars in inches and centimeters.

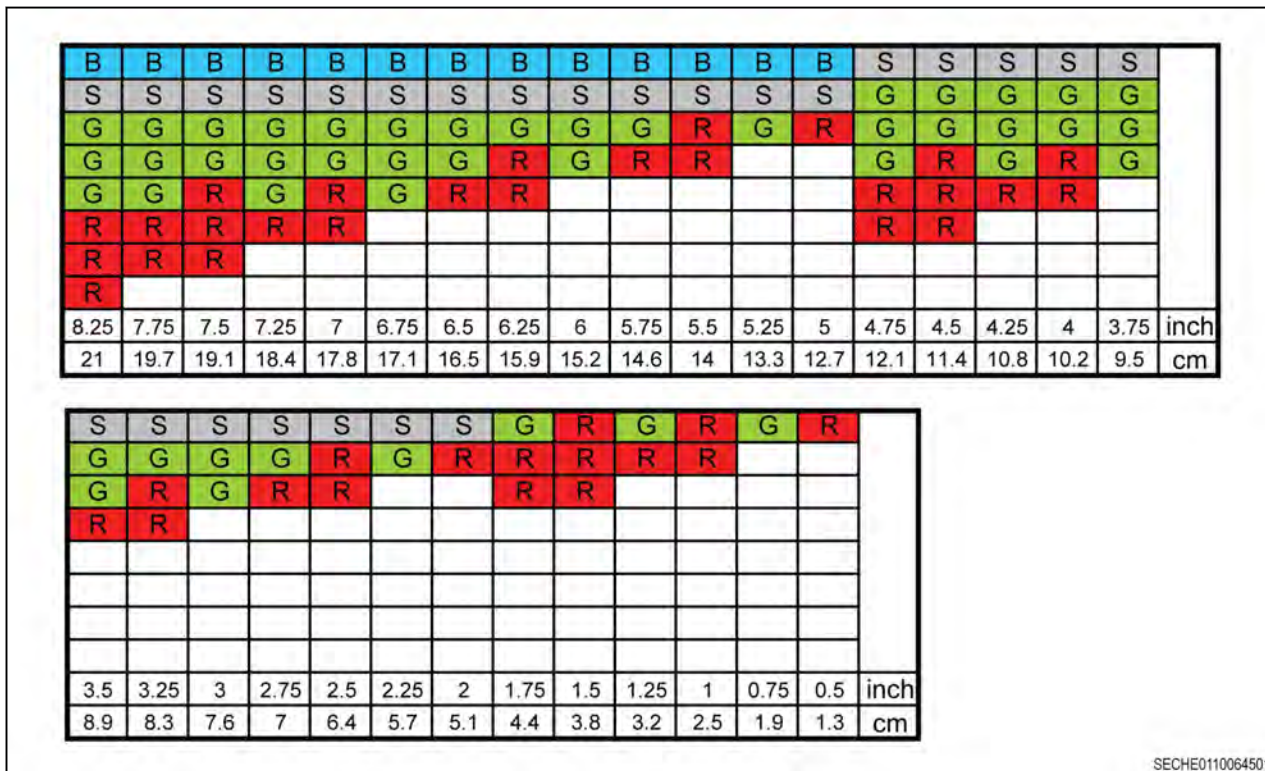

SECHE0110064501

Fig. 43

3.19.3 Initial seed depth collar sequences

The initial seed depth collar sequence is the total length of the depth collars installed on the shaft of the frame height cylinders. The initial seed depth collar sequence is a starting point. The sequence of depth collars will change with the field conditions.

Use the following initial seed depth collar sequences when checking seed depth.

- Small Grains and Beans: 19.1 cm (7.5 inch) sequence (blue (2), silver (1))
- Canola: 24.8 cm (9.75 inch) sequence (blue (2), silver (2), green (1))

3.19.4 Adjusting seed depth

Procedure

1. Raise the drill frame to the highest height.
2. Install the recommended initial sequence of depth collars (1) on the shaft of each of the frame height cylinders (2).

NOTE: See the decal on the front of the frame for the sequence of seed depth collars.

3. Operate the drill in the field and check the seed depth.
4. Adjust the sequence of seed depth collars. Check the seed depth until the seed is at the correct seed depth.

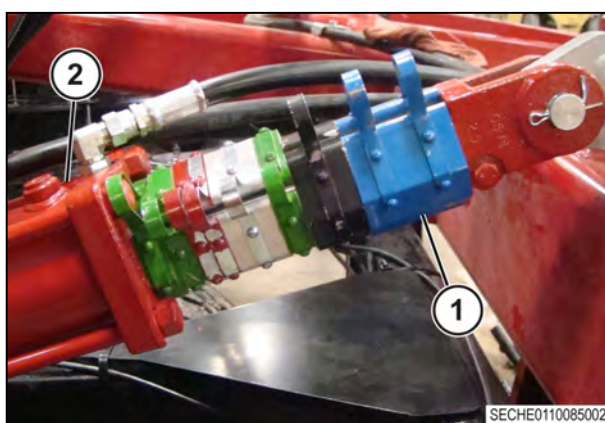

Fig. 44

SECHE0110085002

3.20 Toolbar down pressure

A hydraulic cylinder (1) applies toolbar down pressure on each toolbar (2). The cylinders apply a constant down pressure through the full range of movement of the toolbar. An active hydraulic circuit maintains uniform pressure to each hydraulic cylinder.

Use the terminal to set the toolbar down pressure. The toolbar down pressure can be adjusted from 1034 kPa to 17237 kPa (150 psi to 2500 psi). Set the toolbar down pressure high enough for correct disc penetration and correct soil compaction. The toolbar down pressure adjustment will change with field conditions, seed depth, soil type, and ground speed.

Operate the tractor hydraulic remote that the toolbar down pressure is connected to at full output or fully open. Operating the hydraulic remote at full output reduces the back pressure on the toolbar down pressure return lines.

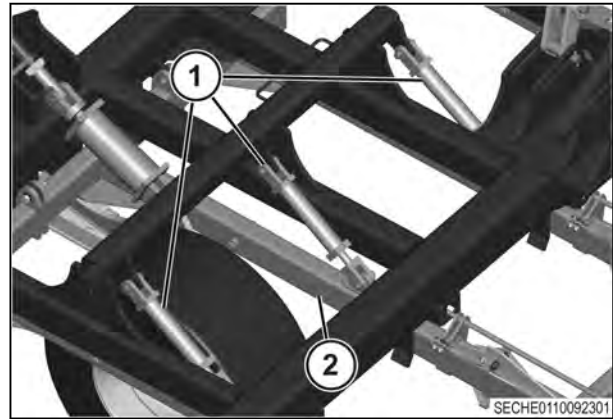

Fig. 45

3.21 Turning at the edge of a field

When turning at the edge of a field, or headland, complete the following steps.

Procedure

1. When approaching the turn, slow the tractor and machine to an acceptable rate of speed to complete the turn.
2. Begin to raise the frame of the machine and start the turn at a point where the machine will clear any obstacles to the outside of the turn.











IMPORTANT: *When lifting the machine for a turn, only lift the frame with the frame height cylinders.*

3. Complete the turn. Watch and make sure the edge of the machine clears any obstacles.
4. After completing the turn, align the machine with the last pass, permitting for the correct amount of spacing or overlap.
5. Lower the frame of the machine to start the next pass.
6. Increase the speed of the tractor and machine to the operating speed.



3.22 Software information

3.22.1 Software icon descriptions



Main screen icons

-  Master apply switch
-  Switch between preset down pressure values
-  Virtual switch box
-  Down pressure settings
-  Product rate settings
-  Next page
-  Calibration screen
-  Totals screen
-  Settings screen
-  Maintenance screen
-  Go back to previous screen



Virtual switch box

-  Select to turn the section on or off
-  Select to prime the meters



Down pressure

-  Increase down pressure
-  Decrease down pressure
-  Select to see the preset value information

Product rate

-  Increase product application rate
-  Decrease product application rate

Maintenance

-  Select to view active errors
-  Select to view stored errors

3.22.2 Main work screen

The implement's operation and monitoring are done from the main work screen.

The main work screen contains this information:

- (1) Active errors
- (2) Section status
- (3) System status
- (4) Product level information
- (5) Product rate information

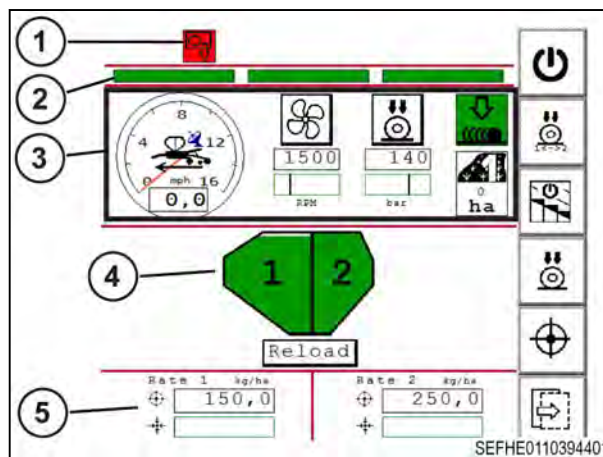











Fig. 46

Active errors

Active error icons include:

-  Rate error
-  Meter error
-  Case drain error
-  Fan speed error
-  Down pressure error
-  Service interval warning
-  Product low - Yellow background
-  Product bridged
-  Product empty - Red background

Section status



There are three sections for the implement. The color will change with the status of each section:

- Green - On

- White - Off when controlled by the vitural switch box or Task Controller
- Yellow - Standby

System status

The speedometer (1) will show the speed of the source of the ground speed:

-  Drill GPS
-  Tractor ISOBUS GPS
-  Hold speed

Select the fan control (2) to turn on or off. The background of the fan control will change:

- Green - manual on
- White - manual off

Below the fan control is a bar chart (3) that shows the target speed and the actual speed.

Select the down pressure (4) to turn on or off. The background of the down pressure will change:

- Green - manual on
- White - manual off

Below the down pressure is a bar chart (5) that shows the target pressure and actual pressure.

The lift state (6) will change:

-  Up
-  Down

Area counter (7) also shows on the main screen.

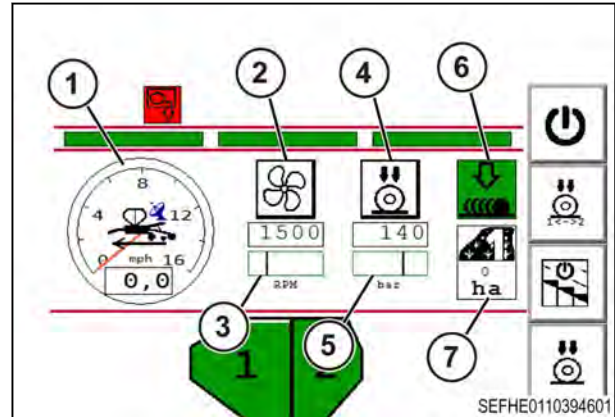

Fig. 47

Product level information

The product level for each hopper (1) is shown.

Select **Reload** to see the reload screen.

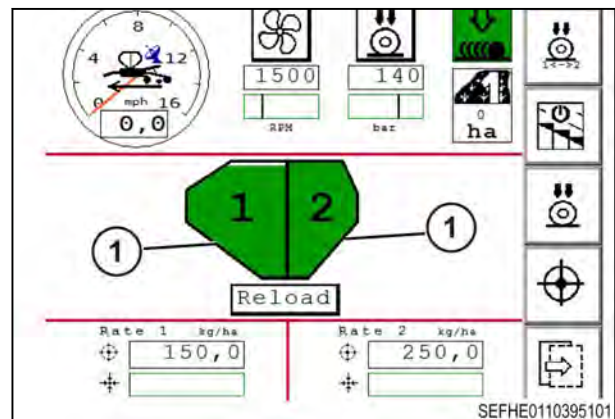

Fig. 48

Product rate information

The product rate information includes the target rate and actual rate for each product. Select the target rate box to change the value.

3.23 System information

3.23.1 Terminal information

Read and understand the terminal operator manual(s) before reading the implement software information.

The terminal operator manual can contain this information:

- Installing the terminal in the tractor
- Button or touch screen operation
- Changing data information
- Volume control
- Display brightness
- Terminal and implement language and measurement units
- Setting the date and time
- Auxiliary input setup for the external master switch
- Ground speed calibration
- Making as applied maps, if available
- Variable rate application, if available

NOTE: For more information on section control with a C1000 terminal, see the Task Controller operator manual.

For more information on section control with a C3000 terminal, see the Auto-Guide 3000 Advanced for C3000 terminal operator manual.

3.23.2 Implement software identification

The software identification information is located on the software maintenance screen.

Select the icons in this order:



The information (1) will change when software is updated.

Give this information to your dealer when necessary:

Software version:	
Software build:	

Select  to go back to the settings screen.

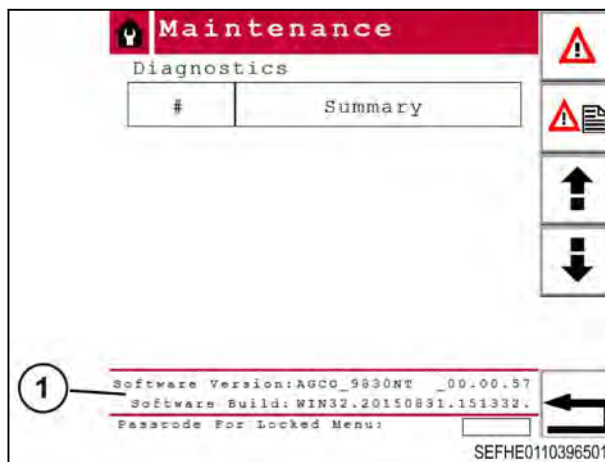

Fig. 49

3.23.3 Master switch

There are two types of master switches:

- External master switch
- Terminal master switch

See the information for external master switch or terminal master switch.

The master switch must be turned off when:

- Transporting
- Stationary
- The operator is not in the tractor

3.23.3.1 External master switch

An external master switch can be used if:

- The terminal harness has an auxiliary function connection, or
- The terminal or tractor has an external auxiliary function switch

Connect the external master switch to the terminal harness close to the terminal. Mount the external master switch within reach of the operator.

During field operation, move the external master switch to the on position to start planting. Ground speed will control the product application rate.

Move the external master switch to the off position to stop planting. The external master switch must be in the off position when:

- Not planting
- Transporting
- Doing maintenance

3.23.3.2 Terminal master switch

During field operation, select  to start planting.

The background color of the terminal master switch will change:

- White - terminal master switch off
- Yellow - stand-by
- Green - seeding

Ground speed will control the product application rate.

Select  to stop seed flow.

3.23.4 Virtual switch box

On the implement main screen, select  to see the virtual switch box.

The virtual switch box is used to manually turn individual sections or hoppers on and off without turning the master switch off.

The virtual switch box is also an alternative to a physical switch box, if one is not available.

There are two ways turn on or off a section:

- Select the icon (1) on the right side of the screen, or
- Select the section (2)

Select the correct hopper (3) to turn on or off.

If  is selected, the meters assigned to the product and/or sections that are active (on the virtual switch box screen) will turn one complete revolution at the set rpm "meter speed" on the calibration screen.

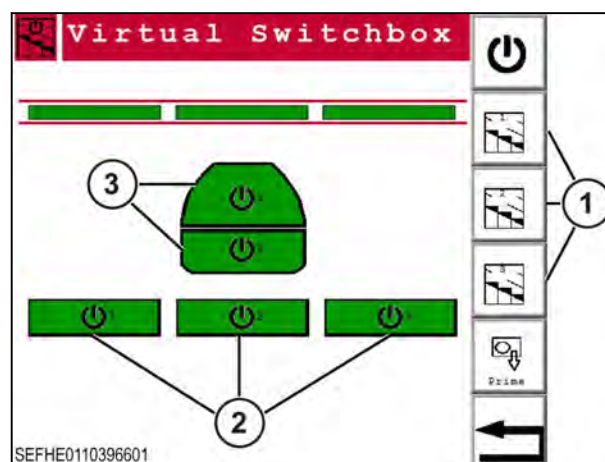



Fig. 50

This procedure lets the operator run a some product out of the meter to be sure no lines are plugged before starting a field.

Select  to go back to the settings screen.

3.24 Implement setup

3.24.1 Changing the implement settings

Procedure

1. Select the icons in this order:



2. If a lift switch is connected, enable the lift switch (1).
3. If the lift switch is reversed, make sure there is a checkmark in the box (2) next to **Reversed**.
4. Select the box (3) next to **Low Speed Alarm** to set the low fan speed alarm.
5. To hear a sound each time the master apply switch is turned on, enable the master apply beep (4).
6. Select the ground speed source (5).
 - Drill GPS
 - ISOBUS
7. Select the type of rate control (6).
 - Per section
 - Full width of the implement
8. Select  to go back to the main screen.

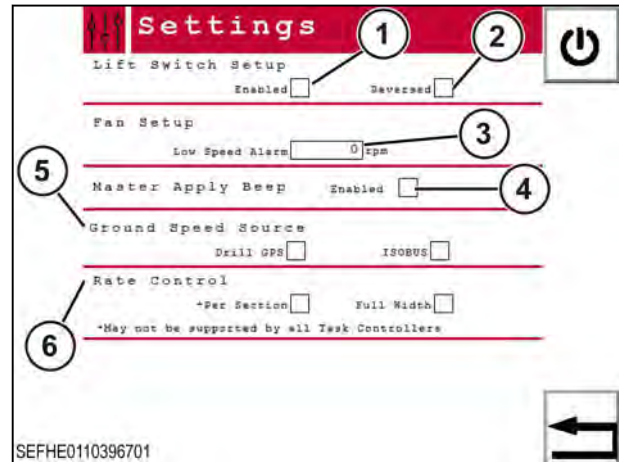

Fig. 51

3.24.2 Calibrate a drill section

NOTE: The catch bag must be empty each time the calibration process is started.

Procedure

1. Weigh the empty container.
2. Put the container in position to catch the product from one section.
3. On the terminal, select the icons in this order:



4. Put a checkmark in the box (1) for the section to be calibrated.
5. Use the keypad outside the machine to start and stop the motors.
The #1 button controls the front hopper and the #2 button controls the rear hopper.
6. Weigh container for each product.
Use the scale supplied to weigh the container.
7. Calculate the catch weight.
Subtract the container weight from the total to get the catch weight.
8. Enter the catch weight value (2) for each product.
9. Select to go back to the main screen.

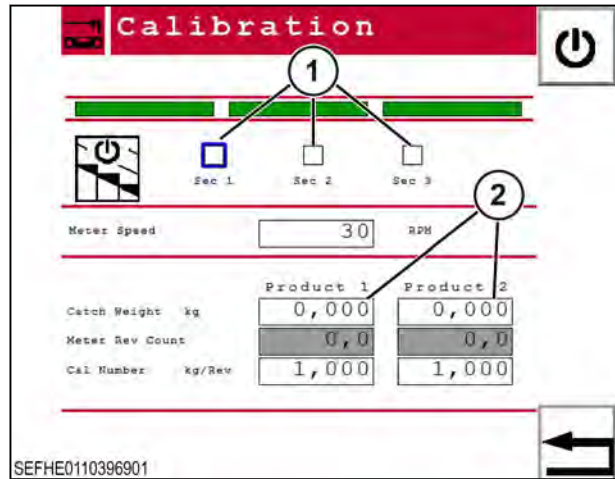

Fig. 52

3.24.3 Setting the down pressure

Procedure

1. Select the box (1) below to enter a specific value.
2. Use the number pad to enter the down pressure value.
3. Select .
4. Select to move between two preset down pressure values.
5. To change the preset values or the other values all on one screen, select on the right side of the screen.
6. Select the box (1) next to to enter a specific value.
7. Use the number pad to enter the down pressure value.
8. Select .
9. Select the box (2) next to **Bump Amount** to change the interval the down pressure will change.
10. Use the number pad to enter the down pressure value.
11. Select .

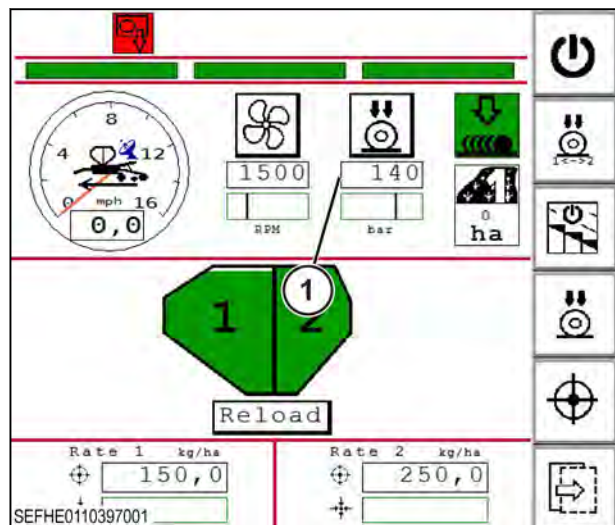

Fig. 53

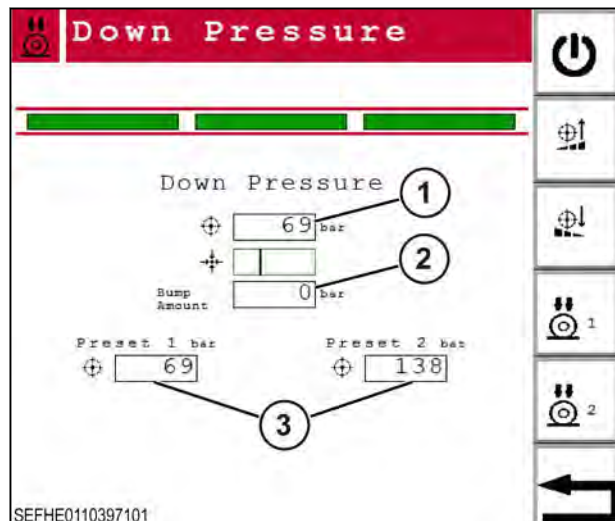















Fig. 54

12. To increase the down pressure by the bump amount, select .
13. To decrease the down pressure by the bump amount, select .
14. To change one of the preset down pressure values, select the box (3) next to .
15. Use the number pad to enter the down pressure value.
16. Select .
17. Select  to go back to the main screen.

3.24.4 Setting the product rate

Procedure

1. To change **Rate 1** (1), select the box (2) next to  to enter a specific value.
2. Use the number pad to enter the down pressure value.
3. Select .
4. To change **Rate 2** (3), select the box (4) next to  to enter a specific value.
5. Use the number pad to enter the down pressure value.
6. Select .
7. To change more product rate information, select  on the right side on the screen.
8. To change **Rate 1** (1), select the box (2) next to  to enter a specific value.
9. Use the number pad to enter the down pressure value.
10. Select .
11. To change **Rate 2** (3), select the box (4) next to  to enter a specific value.
12. Use the number pad to enter the down pressure value.
13. Select .

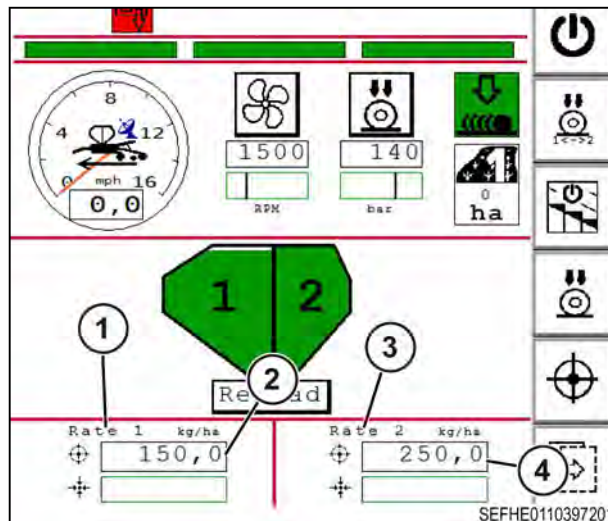

Fig. 55

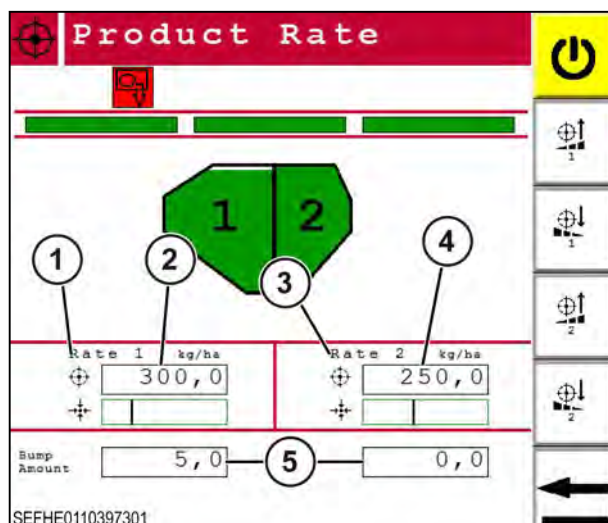





Fig. 56

14. Select the one of the boxes (5) next to the **Bump Amount** to change the interval the product rate will change
15. To increase one of the product rates by the bump amount, select .
16. To decrease one of the product rates by the bump amount, select .
17. Select  to go back to the main screen.

3.24.5 Loading the bins

Procedure

1. Select **Reload** (1).

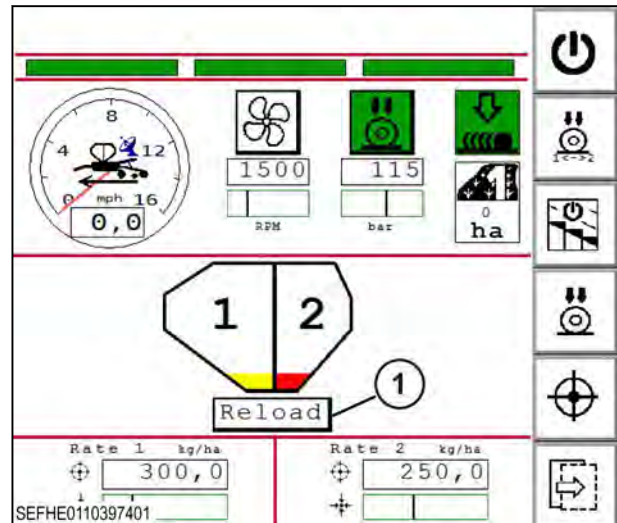





Fig. 57

2. Select **Prod 1 100%** (1) to make hopper 1 (2) full.
3. Select **Prod 2 100%** (3) to make hopper 2 (4) full.
4. To add product by weight to the hoppers, select one of the boxes (5) next to **Weight**.
5. Use the number pad to enter the value.
6. Select .
7. Select the Density value box (6) for each product.
The product density must be added for each product to have an accurate value of % full and weight.
8. Use the number pad to enter the value.
9. Select .
10. Select  to go back to the main screen.

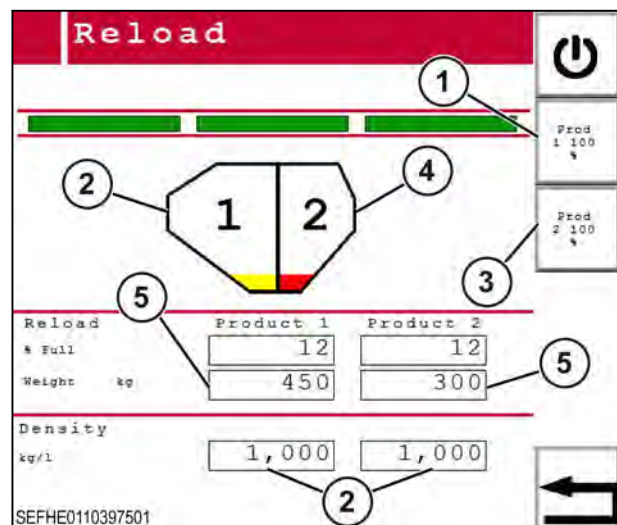

Fig. 58

3.25 Totals

Select the icons in this order to see the totals screen:



The totals screen includes this information:

- (1) Two area counters that can be reset
- (2) Two hopper area counters that can be reset
- (3) Lifetime area counter
- (4) Lifetime metering counter
- (5) Lifetime product used counter
- (6) Lifetime fan usage counter

Select  to go back to the main screen.

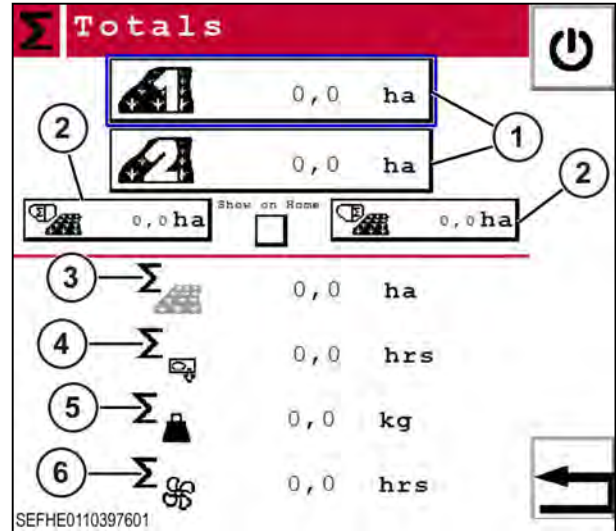

Fig. 59

3.26 Maintenance

Select the icons in this order to see the maintenance screen:



Select to see a list of active errors.

Select to see a list of stored errors.

Select to go back to the main screen.

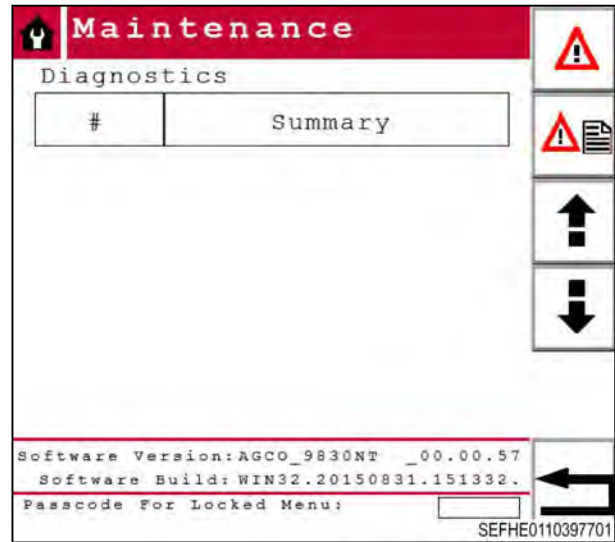

Fig. 60

4. Maintenance

4.1 Lubrication points	97
4.1.1 Lubrication and maintenance chart	97
4.1.2 Lubrication fitting locations	98
4.2 Servicing the wheel bearings	101
4.3 Storage	102
4.3.1 Preparing the machine for storage	102
4.3.2 Preventing corrosion of extended hydraulic cylinders	103
4.3.3 Removing the machine from storage	103

4.1 Lubrication points

See the machine specification for the correct lubricant.

Shut off the engine, lower the machine to the ground, set the parking brake and the the key with you.

Do not let grease build up on or around parts, especially when operating in sandy soil.

Make sure to clean the lubrication fittings fully before connecting the grease gun.

Watch each lubrication point while lubricating to make sure the lubricant applies correctly.

Check for any loose, missing, or worn parts when lubricating the machine.

Check the lubrication service schedule for the correct lubrication interval.

4.1.1 Lubrication and maintenance chart

Severe conditions or conditions that are not normal will require more frequent lubrication.

See the machine specifications for the correct type and quantity of lubricant.

10 hours or daily	50 hours or weekly	1000 hours or yearly	
X			Lubricate the transport wheel walk beams, two fittings per beam.
X			Lubricate the transport wheel struts, two fittings per strut.
X			Lubricate the rear hitch pivot pins, one fitting per pivot.
X			Lubricate the bander disc struts on the fertilizer bander attachment, one fitting per strut
	X		Lubricate the hopper shutoff bushings, two per shutoff
	X		Lubricate the wing frame pivot points, one fitting per pivot.
	X		Lubricate the ring hitch, two fittings per hitch.
	X		Inspect all hardware installed on the machine for the correct torque.
	X		Inspect all wheel lug bolts and wheel nuts for the correct torque.
	X		Check air pressure of all tires. Inflate tire to correct pressure.
	X		Clean any dirt or grease from moving parts.
		X	Lubricate the packing wheel and disc hub, one fitting per hub
		X	Remove and clean the bearings from each hub assembly. Fill the bearings and hubs with new grease.
		X	Remove and clean the bearings from each walking tandem. Fill the bearings with new grease.
		X	Inspect all hydraulic hoses and fittings for cracks or leaks. Replace any hoses or fittings as necessary.

4.1.2 Lubrication fitting locations

Transport wheel walk beams

Find the two grease fittings (1) on each transport wheel walk beam.

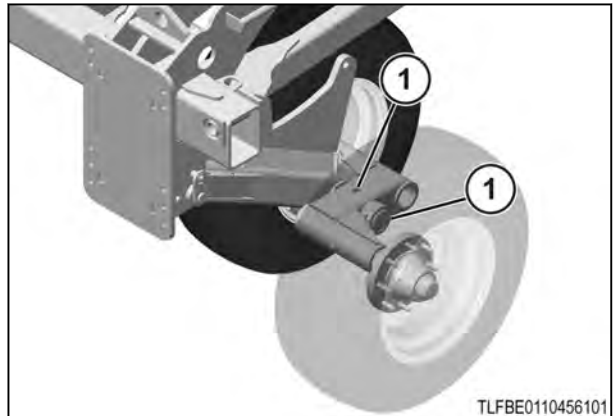

Fig. 1

Transport wheel struts

Find the two grease fittings (1) on each transport wheel strut.

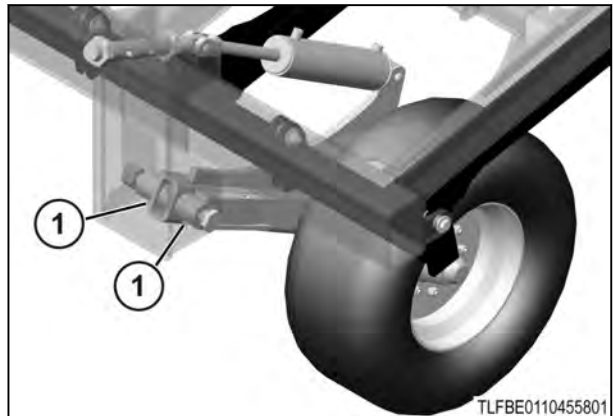

Fig. 2

Rear hitch pivots

Find the one grease fittings (1) on each rear hitch pivot pin (2).

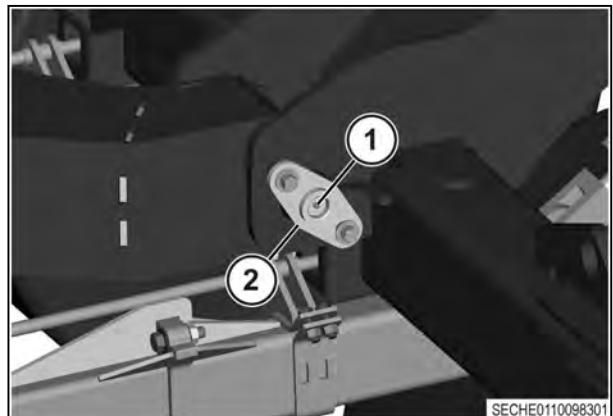

Fig. 3

Fertilizer bander strut pivot

Find the grease fittings (1) for each fertilizer bander strut pivot (2) in front of the pivot.

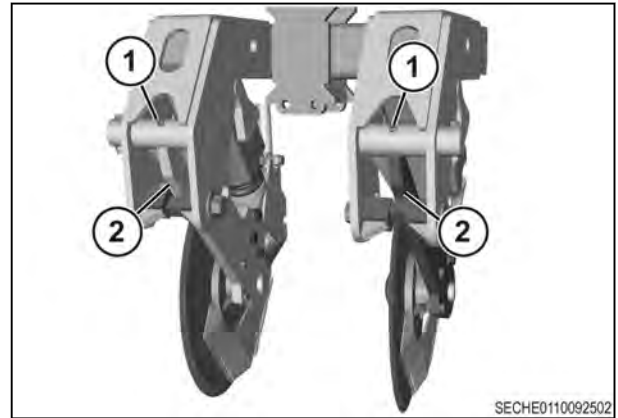

Fig. 4

Wing frame hinge point

Find the one grease fitting (1) on each pivot point.

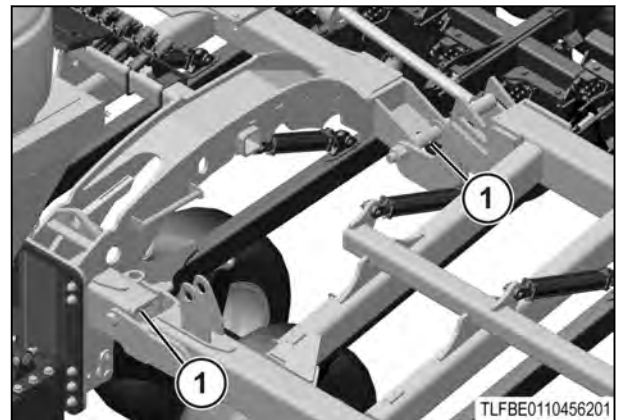

Fig. 5

Packing wheel

Find the one grease fitting (1) on each wheel hub assembly.

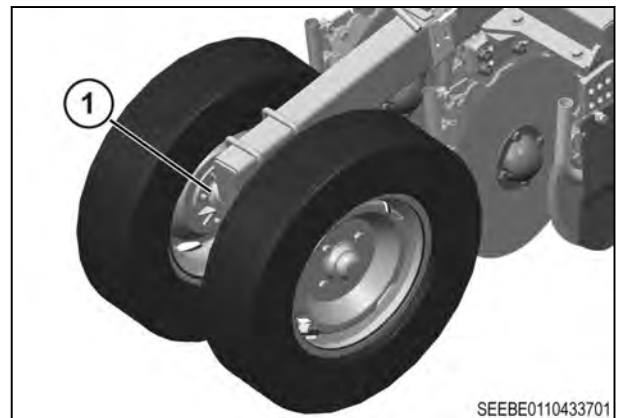

Fig. 6

Disc hub

Find the one grease fitting (1) on each disc hub assembly.

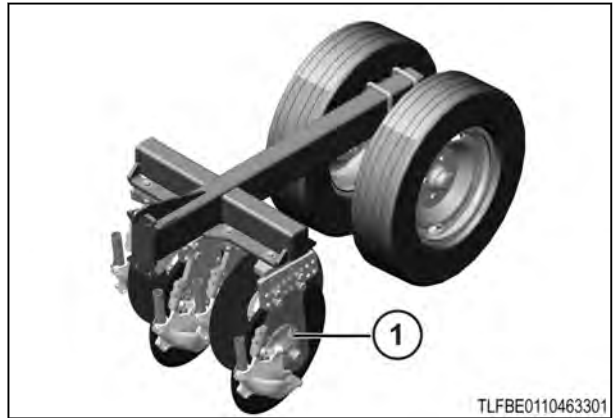

Fig. 7

Ring hitch

Find the two grease fittings (1) on each hitch.

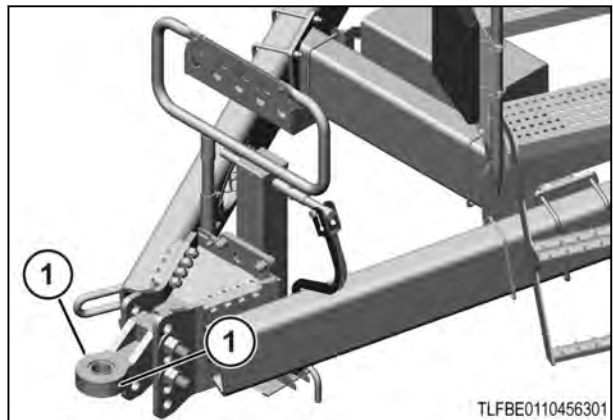

Fig. 8

Hopper shutoff bushings

Find the two grease fittings (1) on each shutoff.

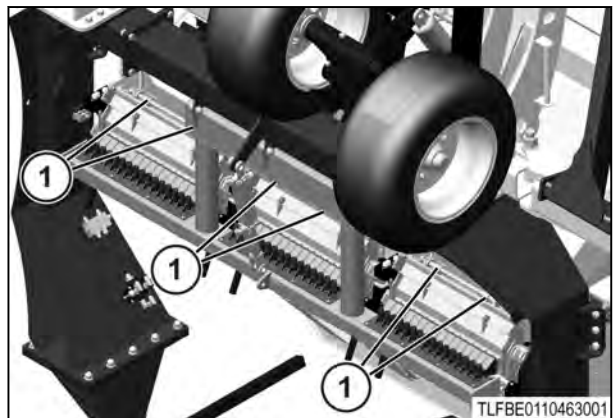

Fig. 9

4.2 Servicing the wheel bearings

Clean and fill the wheel hubs yearly. Cleaning and filling the hubs removes all dirt and supplies fresh grease.

Procedure

1. Remove the hub and bearing.
2. Clean the old grease out.
3. Manually pack the bearings.
4. Assemble the hub and bearings.
5. With the hub cap off, use the grease fitting to fill the hub.
6. Stop filling the grease when it starts to push out the bearing.
7. Install the hub cap.

4.3 Storage

4.3.1 Preparing the machine for storage

Prepare the machine for storage at the end of each season. When possible, store the machine in a covered location with the wings lowered. Preventing rust will lengthen the life and assist in performance.

Procedure

1. Park the machine on a solid, level surface, away from other machines.
2. Use the tractor hydraulics to lower the wings of the machine.
3. Clean the machine of any dirt, grease, or other materials.
4. Put a protective layer of heavy oil or grease on all earth engaging parts to prevent rust.
5. Paint any damaged surfaces, surfaces with paint removed, or surfaces with rust.
6. Inspect the machine for any loose parts or hardware.
 - a) Replace any worn parts.
 - b) Tighten any loose hardware.
7. Lubricate all components of the machine.
8. Raise the machine and transport the machine to the area where the machine is to be kept. The area must be level and away from other machines.
9. Use the tractor hydraulics to lower the wings of the machine.
10. Stop the engine, apply the park brake, and take the key with you.
11. Remove the hardware that fastens the cylinder rod (1) of the wing lift cylinders to the wing frame. If equipped with folding wing extensions, remove the pins fastening the rod end of the wing lift cylinders to the wing extension frame.
12. Put boards under the gangs or shanks.
13. Start the tractor. Use the tractor hydraulics to retract the wing lift cylinders.
14. Stop the engine, apply the park brake, and take the ignition key with you.
15. Block up the machine to remove the weight from the tires.
16. Use the front hitch jack (1) to support the front hitch of the machine.
17. Disconnect the machine from the tractor. See the information for disconnecting the machine from the tractor.
18. Apply grease to the surfaces of the cylinder rods that are still showing.

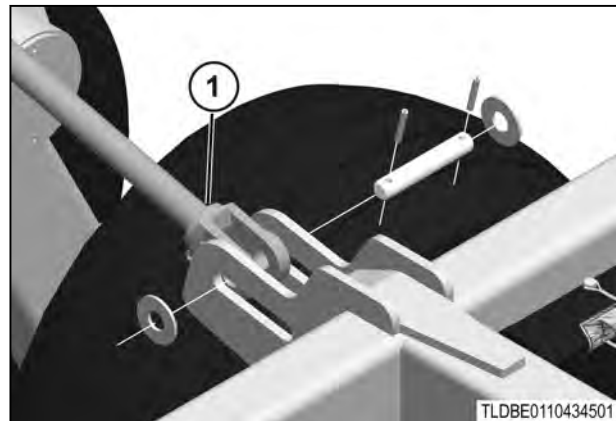

Fig. 10

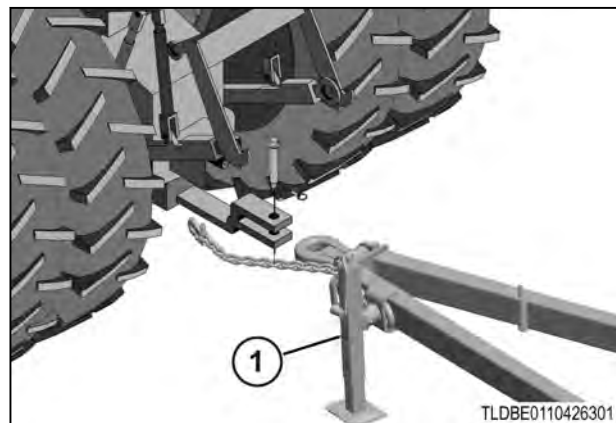

Fig. 11

4.3.2 Preventing corrosion of extended hydraulic cylinders

Store the machine with the cylinders in the retracted position. If the machine is stored with cylinders in the extended position, periodically cycle the cylinder. If a cylinder must be stored in the extended position without being cycled, the following corrosion prevention must be done.

Procedure

1. Use a dry cloth or cloth with solvent to clean any dirt from the cylinder shaft.
2. Prepare a mixture of 60 percent oil based rust inhibitor and 40 percent Kerosene.
3. Use a cloth to apply a thin layer of this mixture to the surface of the chrome plated shaft.
Number one fuel oil can be replaced with Kerosene. A good grade purpose made product can be used for this procedure.
4. Follow manufacturer instructions for applying purpose made products.
5. Inspect and apply the mixture again at three to six month intervals.

4.3.3 Removing the machine from storage

Complete the following steps to remove the machine from storage.

Procedure

1. Connect the machine to the tractor.
2. Use the tractor hydraulics to extend the wing fold cylinders. Extend the wing fold cylinders until the holes in the end of the wing fold cylinders align with the holes in the mounts.
3. Stop the engine, apply the tractor park brake, and take the key with you.
4. Install the cylinder rod (1) of the wing fold cylinders to the mount on the wing frames. Use the existing hardware to fasten the wing fold cylinders.
5. Check the air pressure in all the tires.
6. Inspect all the hydraulic hoses and the connections for leaks and repair as necessary.
7. Make sure the safety signs are visible and not damaged.

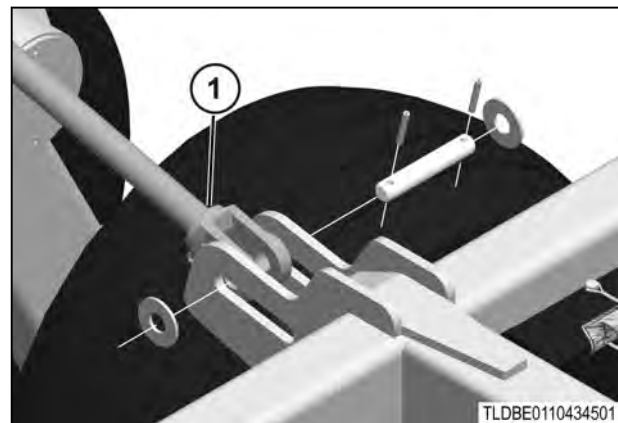

Fig. 12

5. Troubleshooting

5.1 Troubleshooting 107

5.1 Troubleshooting

Too much seed cracking.	
Cause(s)	Solution(s)
Air stream velocity is too great.	Decrease the blower speed.

The seed boots are plugging.	
Cause(s)	Solution(s)
Turning too sharply with boots in the ground.	Always lift ground opener before turning.
The ground openers have been left in the ground when the machine is backed up.	

There is oil on the seed lines.	
Cause(s)	Solution(s)
The shaft seal failed on the hydraulic motor.	Replace the seal. Do not disassemble hydraulic motor. The shaft seal is an external replacement.

The hydraulic motor is slow.	
Cause(s)	Solution(s)
The monitor set to the wrong blower speed setting.	See the information for the terminal.
The tractor is not putting out sufficient oil.	Have the tractor dealer inspect the tractor hydraulics.
The hydraulic couplers are bad.	Check the couplers on the tractor and the hoses. Try different couplers.

Seeding is uneven.	
Cause(s)	Solution(s)
The plenum is plugged.	Clean out the plenum.
The plenum is leaking	Adjust the plenum bulkheads and cylinder.
	Seal the plenum access covers.
The final run is plugged.	Clear the obstruction.

The final runs are plugged.	
Cause(s)	Solution(s)
The fan speeds are too low.	Increase the fan speed.
The venturi is blocked.	Clear the blockage.
The seed boot is blocked.	Clear the blockage.

The final runs are plugged.	
Cause(s)	Solution(s)
The seed rate is too high .	Slow down or decrease the seed rate.
The plenum is leaking.	Adjust the plenum bulkhead and cylinder.
The final run hoses are not routed properly.	Remove all the slack in the hoses with the toolbars fully extended with the machine up.

The product is not shutting off at hopper.	
Cause(s)	Solution(s)
The hopper gates are not closing.	Re-time the rack and pinion.
	Clear debris from the gates and sliders.

The meter does not turn.	
Cause(s)	Solution(s)
The meter is jammed.	Clear the jam (alarm will occur).
The key has fallen out.	Replace the key in the gearbox and shaft.
The gearbox and motor have become disconnected.	Remove the cover and reset the set screw in transition.
No power/communication (alarm will occur).	Check the fuses and the electrical connections.
No rate set in the terminal.	Set the rate in the terminal.
Section/product is not on.	Turn on the section/product.
The minimum speed is not met.	Exceed the minimum speed set point 1.6 km/h (1 mph).
The work switch is not enabled.	Enable the master apply switch.
	Be sure the implement work switch is down.

The meter turns but no product is delivered.	
Cause(s)	Solution(s)
The product may be bridged.	Clear the debris from above the meter.
The product gate is not open.	Open the product gate.

The ground speed is erratic.	
Cause(s)	Solution(s)
The sensor does not have a clear view to the sky.	Move into an open area.
	Clear the debris from the sensor.
The sensor is defective.	Replace the sensor on the wing tip.
The wiring is defective.	Check the connections.
	Check for broken or damaged wires.

The fan speed is erratic.	
Cause(s)	Solution(s)
The sensor is not adjusted correctly.	Adjust the sensor between 1 mm and 3 mm away from the target.
The sensor is damaged.	Replace the sensor.
The wiring is defective.	Check for broken or damaged wires.

The hopper full/empty sensor is not operating correctly (status light: green=empty, red=full).	
Cause(s)	Solution(s)
The sensitivity is set too strong.	Turn the screw out to relieve the sensitivity.
The sensing face is blocked.	Remove the blockage and clean the sensor face.
The wiring is defective.	Check for broken or damaged wires.
The sensor is defective.	Replace the sensor.

The machine does not apply seed.	
Cause(s)	Solution(s)
The minimum speed is not met.	Increase the speed.
The master apply switch is not enabled.	Press the master apply button.
The implement switch is not activated.	Lower the implement.
The fan is not active.	Turn on the fan and set the speed.
The down pressure is not active.	Turn on the down pressure.
No rate is set in the monitor.	Set the rate.
No calibration number is populated.	Calibrate meter and enter the value.

The downpressure is not controlling.	
Cause(s)	Solution(s)
The hydraulics are not on.	Turn the hydraulics on constant.
The oil flow from the tractor is not sufficient.	Increase the oil flow from the tractor.
	Check the hydraulic couplers and hoses.

The fan speed is not controlling.	
Cause(s)	Solution(s)
The hydraulics are not on.	Turn the hydraulics on.
The oil flow from the tractor is not sufficient.	Increase the oil flow from the tractor.
	Check the hydraulic couplers and hoses.
The case drain pressure is too high.	Check the case drain coupler and hoses.

The seeding rates are not accurate	
Cause(s)	Solution(s)
The calibration number is bad.	Calibrate again.
The ground speed is too slow.	Increase the ground speed.
	Change the meter roll and calibrate again.
The ground speed is too fast.	Decrease the ground speed.
	Change the meter roll and calibrate again.

There is no communication from the implement.	
Cause(s)	Solution(s)
The implement is not connected to the tractor.	Connect the ISOBus harness and power cable to the tractor.
There is no power from the tractor.	Fully power up the tractor with the VT.
	Check for power at the ISOBus plug on the tractor

The implement switch does not work correctly.	
Cause(s)	Solution(s)
The targets are missing.	Replace the targets.
The wiring is defective.	Check for broken or damaged wires.
The sensor is defective.	Replace the defective sensor.
The resistor is bad.	Replace the bad resistor.

No fan speed.	
Cause(s)	Solution(s)
The hydraulics are not connected to the tractor	Connect the hoses to the hydraulic ports
The hydraulics are connected to the incorrect couplers	
The fan control valve is not connected.	Check for broken or damaged wires.
	Check the control valve connections.
The fan speed sensor is faulty.	Replace the fan speed sensor.

The fan speed is low.	
Cause(s)	Solution(s)
The tractor hydraulic flow setting is too low.	Increase the hydraulic flow.
The fan speed sensor is faulty.	Replace the fan speed sensor. .

The fan speed is high.	
Cause(s)	Solution(s)
The fan control valve is not connected.	Check for broken or damaged wires.
	Check the control valve connections.
The fan speed sensor is faulty.	Replace the fan speed sensor.

Case drain pressure error.	
Cause(s)	Solution(s)
The case drain coupler is not connected.	Connect the case drain coupler to the port on the tractor.
The case drain line has a restriction.	Check the coupler.
	Check the hoses for a kink or pinch.
The case drain is connected to a pressure port.	Disconnect the pressure port and connect to the correct port on the tractor.

6. Specifications

6.1 Specifications	115
6.2 Transport dimensions	116
6.3 Minimum tow vehicle weight	117
6.4 Maximum transport speed	118
6.5 Lubrication specifications	119
6.6 Frame and rear hitch tire air pressure	120
6.7 SAE fastener torque specifications	121
6.8 Torque specifications for hydraulic tubes and fittings	122
6.9 Torque specifications for O-ring boss plugs, adjustable fitting lock nuts and JIC-37 seats	123

6.1 Specifications

Size	Sections	Power requirements	Base weight
9.14 m (30 ft)	3	168 kW to 242 kW (225 hp to 325 hp)	11091 kg (24400 lb)

Size	Seed openers	Fertilizer openers	Weight with fertilizer banders	Ballast kit weight
9.14 m (30 ft)	48	24	13154 kg (29000 lb)	581 kg (1 280 lbs)

Tire sizes	
Main frame support tires	440/55R18 159A8/B TL (GY)
Wing frame support tires	36 x 17.5 8 ply
Floating rear hitch tire	12.5L-15 8 ply

Toolbar specifications	
Disc size	45.7 cm (18 in)
Seed depth	0 cm to 7.6 cm (0 in to 3 in)
Row spacing	15 cm to 23 cm (6 in to 9 in) pair row

Hopper capacity (60/40 split)	
Front hopper	3700 L (105 bu)
Rear hopper	2500 L (70 bu)

Hydraulic requirements		
132.5 L/min (35 gal/min) flow rate	4 hydraulic remotes	1 case drain

Electrical requirements	
12 volts	45 amps peak

6.2 Transport dimensions

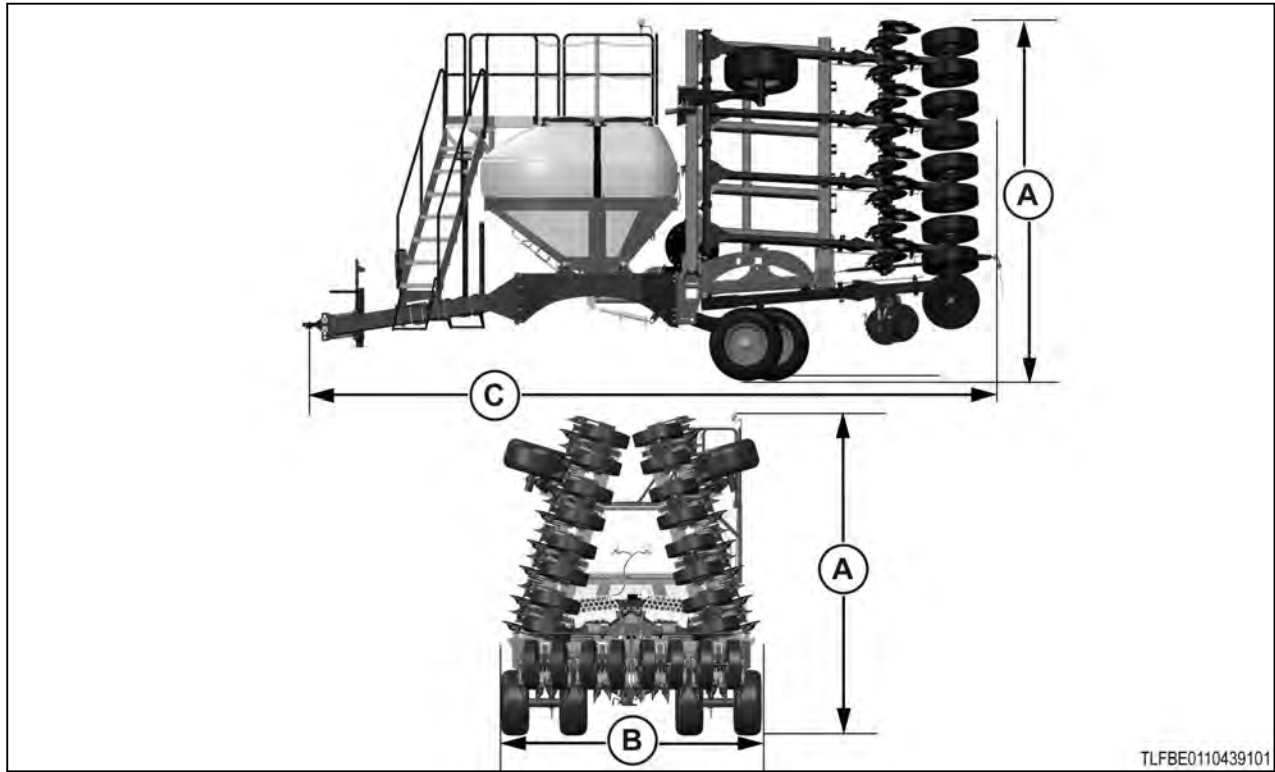

Fig. 1

Model	(A) Transport height	(B) Transport width	(C) Transport Length
9830 NT-30	4.0 m (13 ft 1 1/2 in)	3.5 m (11 ft 6 in)	8.46 m (27 ft 9 in)

6.3 Minimum tow vehicle weight

NOTE: Minimum tow vehicle weight calculated for a machine with mid-row banders and full hoppers towing a 11.8 cu m (335 bushel) cart full of product.

Model	Minimum tow vehicle weight
9830 NT-30	22000 kg (48500 lbs)

6.4 Maximum transport speed

Maximum speed:

30 km/h (20 mph)

6.5 Lubrication specifications



Model	Lubrication fitting
All	No. 2 multi-purpose lithium grease

6.6 Frame and rear hitch tire air pressure

Tire	Three-section Frame
Main Frame Support Tires	503 kPa (73 psi)
Wing Frame Support Tires	276 kPa (40 psi)
Floating Hitch Tires	248 kPa (36 psi)

6.7 SAE fastener torque specifications

The torque specifications below are for UNC and UNF thread fasteners, plated or unplated, as received from the supplier. Fasteners can be dry or lubricated with normal engine oil. Specifications do not apply if graphite, moly-disulfide, or other extreme pressure lubricant is used.

SAE Grade Number	2				5				8*			
Bolt head identification												
Bolt size maximum	Foot pounds		Newton meters		Foot pounds		Newton meters		Foot pounds		Newton meters	
1/4 in	5	6	7	8	9	11	12	15	12	15	16	20
5/16 in	10	12	14	16	17	20.5	23	28	24	29	33	39
3/8 in	20	23	27	31	35	42	48	57	45	54	61	73
7/16 in	30	35	41	47	54	64	73	87	70	84	95	114
1/2 in	45	52	61	70	80	96	109	130	110	132	149	179
9/16 in	65	75	88	102	110	132	149	179	160	192	217	260
5/8 in	95	105	129	142	150	180	203	244	220	264	298	358
3/4 in	150	185	203	251	270	324	366	439	380	456	515	618
7/8 in	160	200	217	271	400	480	542	651	600	720	814	976
1 in	250	300	339	406	580	696	787	944	900	1080	1220	1464
1 1/8 in					800	880	1085	1193	1280	1440	1736	1953
1 1/4 in					1120	1240	1519	1681	1820	2000	2468	2712
1 3/8 in					1460	1680	1980	2278	2380	2720	3227	3688
1 1/2 in					1940	2200	2631	2983	3160	3560	4285	4827
Bolt head identification marks as per grade. Manufacturing marks may vary.									*Thick nuts must be used with grade-8 bolts.			

6.8 Torque specifications for hydraulic tubes and fittings

Standard torque specifications for hydraulic tubes and fittings							
O-Ring face seal fittings (face seal end)							
Size	Tubing O.D.		Thread size	Foot pounds		Newton meters	
	Inches	Millimeters		Minimum	Maximum	Minimum	Maximum
4	1/4 in	6.4	9/16 in - 20	10	12	14	16
6	3/8 in	9.5	11/16 in - 16	18	20	24	27
8	1/2 in	12.7	13/16 in - 16	32	35	43	47
10	5/8 in	15.9	1 in - 14	46	50	60	68
12	3/4 in	19.1	1 3/16 in - 12	65	70	90	95
14	7/8 in	22.2	1 3/16 in - 12	65	70	90	95
16	1 in	25.4	1 7/16 in - 12	92	100	125	135
20	1 1/4 in	31.8	1 11/16 in	125	140	170	190
24	1 1/2 in	38.1	2 in - 12	150	165	200	225

6.9 Torque specifications for O-ring boss plugs, adjustable fitting lock nuts and JIC-37 seats

Torque specifications for O-ring boss plugs, adjustable fitting lock nuts and JIC-37 seats				
Size	Foot pounds		Newton meters	
	Minimum	Maximum	Minimum	Maximum
4	6	10	8	14
5	10	15	14	20
6	15	20	20	27
8	25	30	34	41
10	35	40	47	54
12	60	70	81	95
14	70	80	95	109
16	80	90	108	122
20	95	115	129	156
24	125	140	163	190

7. Accessories

7.1 Fertilizer bander attachment	127
7.1.1 Adjusting fertilizer bander depth	127

7.1 Fertilizer bander attachment

The optional fertilizer bander attachment (1) applies anhydrous ammonia or fertilizer between the two furrows that are made by the opening disc assemblies. The fertilizer bander attachment is installed forward of the opening disc assemblies.

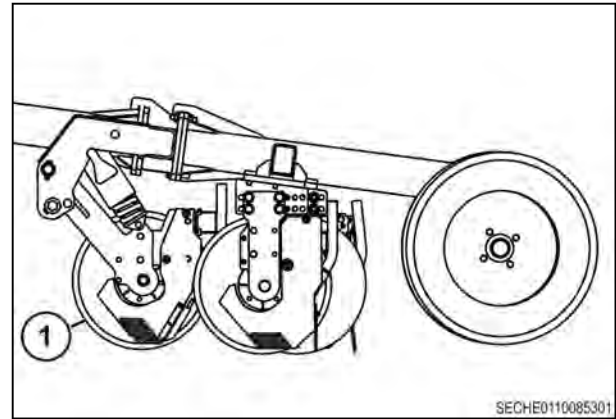

Fig. 1

The depth at which the fertilizer bander applies the fertilizer is set using a cam block (1). The slots (2) in the cam block determine the depth of the fertilizer. The deeper the slot in the cam block; the deeper the fertilizer is applied.

IMPORTANT: *When operating in rocky soil conditions, do not operate at a high rate of speed. High speeds in rocky conditions will damage the fertilizer bander attachment.*

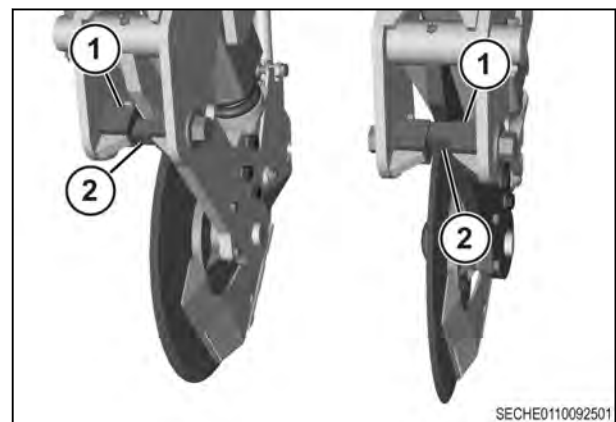

Fig. 2

7.1.1 Adjusting fertilizer bander depth

Before starting the procedure

To adjust the fertilizer bander depth the machine must be connected to the correct size of tractor to operate the machine.

Procedure

1. Raise the frame of the machine until the bander discs are off of the ground.
2. Stop the tractor. Stop the engine, apply the tractor park brake, and take the ignition key with you.
3. Place a wooden block below one of the discs (1) on the fertilizer bander attachment that is to be adjusted.
4. Start the tractor and lower the machine to the ground.
5. Stop the tractor. Stop the engine, apply the tractor park brake, and take the ignition key with you.

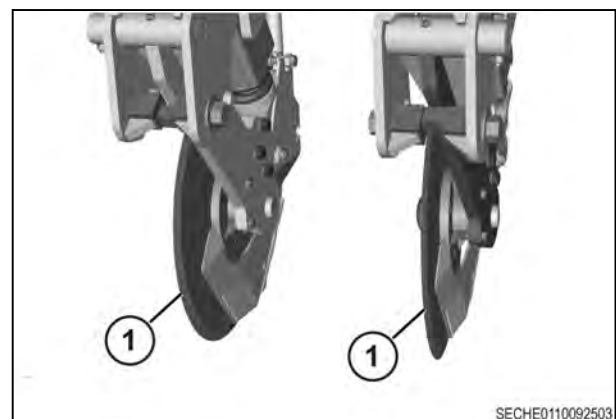

Fig. 3

6.



CAUTION:
Make sure the fertilizer bander disc is firmly supported by the wooden block. If the fertilizer bander disc is not firmly supported then start the tractor, raise the machine, and reposition the wooden block.

Remove the bolt (1) and washer (2) securing one end of the cam block (3) for the bander disc (4) being supported by the wooden block.

7. Slide the cam block out of the bander frame.
8. Install the cam block in the bander frame so the desired depth groove in the cam block will contact the bander disc strut.
9. Secure the cam block in the bander frame using the existing bolt and washer.
10. Start the tractor and raise the machine until the bander disc is off of the wooden block.
11. Stop the tractor. Stop the engine, apply the tractor park brake, and take the ignition key with you.
12. Remove the wooden block from below the bander discs.

After finishing the procedure

Use the same procedure to adjust the remaining bander disc on the fertilizer bander attachment and the other bander attachments.

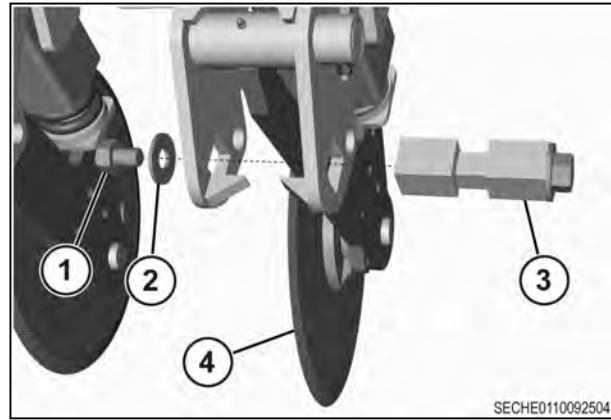

Fig. 4

8. Assembly

8.1 Preparing for assembly	131
8.1.1 Service parts	131
8.2 Assembling the cast boot	132
8.3 Checklists	133
8.3.1 Pre-delivery checklist	133
8.3.2 Delivery checklist	133

8.1 Preparing for assembly

**WARNING:**

Components can be heavy. Severe injury can result from improper lifting technique. Use appropriate lifting equipment for heavy components.

Read this section carefully before assembly. Refer to the Parts Catalog for additional component illustrations while assembling the machine.

Part numbers are shown on labels on the parts.

Hardware numbers are shown on labels on the hardware or on the container the hardware is in.

Carefully remove all the parts and hardware included. Make sure nothing was damaged or missing.

Tighten all hardware according to standard torque values unless specified in these instructions. See the torque charts in this publication for more information.

Always replace hardware with the same grade or class.

Use all the nuts and bolts in the correct locations. This will prevent damage to the machine.

IMPORTANT: *When two or more bolts are being used on a part, always insert the bolts and loosely tighten the nuts. Once the correct location has been reached, tighten the nuts evenly to prevent misalignment or distortion of the parts. Tighten all U-bolt nuts evenly and to the same torque to prevent misalignment or distortion.*

Select a large, flat, and hard surface for assembly of machine.

IMPORTANT: *Keep all parts in the assigned containers until the parts are to be used.*

NOTE: *Some items will be assembled at the factory.*

Right-hand and left-hand, as used in this manual, are determined by facing the direction the machine will travel when in use.

8.1.1 Service parts

The illustrations and part numbers in this publication are supplied for component identification only when assembling the machine. When ordering replacement parts, always use the part numbers from the parts catalog.

For a complete list of available service parts, go to www.agcopartsbooks.com or contact your dealer.

8.2 Assembling the cast boot

Procedure

1. Assemble the boot (1), hinge pin and torsion spring as shown.
2. Put the assembly tool (2) on the exposed pin.
3. Use a wrench to turn the tool until it touches the spring.
4. Turn the spring until it goes past the retainer slot.
5. Put the spring retainer pin (3) into the retainer slot.

Result

Make sure the pin is flush with the face of the strut or it could fall out during operation.

6. Remove the assembly tool and install the retainer plates (4).
7. Install the two flat washers (5), lock washers (6) and 1/2 inch hex bolts (7).
8. Push on the top of the boot until the front edge of the boot evenly rides on the disc.
9. Tighten the two 1/2 inch hex bolts (7).

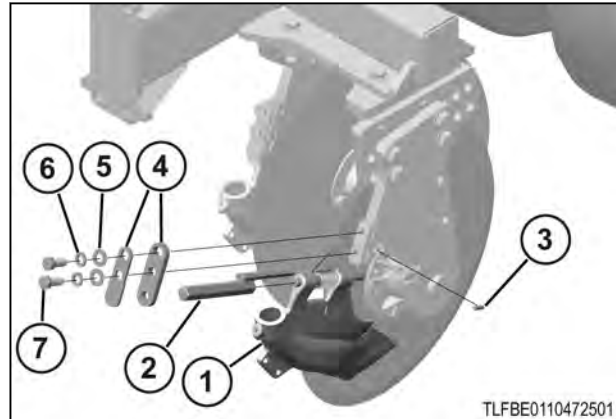

Fig. 1

8.3 Checklists

8.3.1 Pre-delivery checklist

Attention dealer, refer to AGCO SOURCE for machine pre-delivery inspection information.

8.3.2 Delivery checklist

- Make arrangements for dealer personnel to be present when starting the machine in the field. Confirm all systems are working correctly. Review the Operator's Manual to confirm the machine is set up correctly.
- Explain the Warranty of the machine to the owner. Complete the Warranty Registration form and list the serial number of the machine. The dealer and the owner must both sign the form.
- Review the Safety Section with the machine operator. Review various warning decals for dangerous operating procedures or conditions. Instruct the owner of the machine to review the operator manual with each operator of the machine.
- If required, review with operator how to adjust, connect, or disconnect other attachments to the machine.
- Review with the operator the locations and functions of the controls. Refer to the Operation section
- Inform the operator about the adjustments for varying field conditions.
- Inform the operator about the importance of proper lubrication and servicing. Refer to the Lubrication and Maintenance Section.
- Review with the operator the use of the lighting system when operating a machine on the road at night and during the day. The tail lamps, warning lamps, and SMV (Slow Moving Vehicle) emblem must be used for warning operators of other vehicles. Inform the customer to check local government regulations that deal with movement of slow and over width vehicles.
- Give the Operator's Manual to the owner. Make sure the owner will review all sections of the manual.

Index

A

adjusting the cast boot	73
agricultural chemicals	15
assembly	
preparing for	131

B

bins	
loading	92
blower	64
blower speed	64

C

Cam block	127
cast boot	
assembling	132
chemical ingestion hazard	
safety sign	31
cleanout tray latch	66
crushing hazard	
safety sign	32, 34

D

delivery checklist	133
disconnecting	57
disposal of waste	41, 42
do not step	
safety sign	34
down pressure	
setting	90
drill section	
calibrate	89
drill to tractor hydraulic couplers	60

E

electrical shock hazard	
safety sign	32
exhaust warning	14
explosion hazard	
safety sign	34
external master switch	87

F

fall off hazard	
safety sign	33
Fertilizer bander attachment	
Adjusting depth	127
fire prevention and first aid	19
flying debris	15
flying objects hazard	
safety sign	33
Frame height cylinders	

Phasing	63
Putting in phase	63

G

general maintenance information	18
general safety alert hazard	
safety sign	30, 31

H

high pressure leaks	20
hopper capacity	
safety sign	35
hydraulic fluid injection hazard	
safety sign	31
hydraulic fold system	
bleeding air	61
Hydraulic lift assist	80
hydraulic lift system	
bleeding air	60
hydraulic lock-out valve	
safety sign	35
hydraulic systems	60
hydraulic tubes and fittings	
torque specifications	122, 123

I

implement settings	
changing	89
implement software identification	86
informational messages	9
intended use	41
Introduction	41
ISOBUS connector	54

J

jack handle extension	53
-----------------------------	----

L

ladder and platform	51
loss of machine control hazard	
safety sign	31
lubrication	
lubrication points	97
lubrication and maintenance chart	97
lubrication fitting locations	98
lubrication points	
lubrication	97
lubrication specifications	119

M

machine for transport	
preparing	69

machine from the tractor	57	S	
machine identification	43	SAE fastener	
main work screen	83	torque specifications	121
maintenance	94	safety alert symbol	9
major components	46	safety general information	12
marker lamps	28	safety messages	9
master switch	86	safety sign overview	29
maximum speed	118	safety signs	9
maximum speed sign		seat instructions	13
safety sign	30	seed depth	77
meter latches	65	Seed depth	
meter shaft adjustment	66	Adjusting	79
metering wheels		Checking	77
changing	65	Collar sequences	78
minimum tow vehicle weight	117	Initial collar sequences	79
N		seed depth collar chart	
narrow-transport single disc drill	45	safety sign	34
negative tongue weight hazard		serial number description	43
safety sign	30	serial number plate	43
O		service parts	131
operator manual storage	48	servicing	
P		wheel bearings	101
Packing tire	76	shield and guards	14
patent pending		smv emblem	
safety sign	37	safety sign	36
personal protective equipment	13	software icon descriptions	82
pinch hazard		specifications	115
safety sign	33	T	
plenum		terminal information	86
cleaning	67	terminal master switch	87
lowering	67	the machine for seeding	
plenum operation	67	preparing	70
plenum valve		tire air pressure	120
safety sign	35	tire safety	21
pre-delivery checklist	133	Toolbar	80
prepare for operation	12	Toolbar down pressure	80
preparing for		Toolbar lock-out valve	27
storage	102	toolbar locks	
preventing		locking	24
corrosion of extended hydraulic cylinders	103	unlocking	25
product hopper lids	52	totals	93
product rate		transport	
setting	91	maximum speed	118
proper disposal of waste	41, 42	transport dimensions	116
R		transporting hazard	
reflector, orange		safety sign	32
safety sign	36	travel on public roads	16
reflector, red		troubleshooting	107
safety sign	36	Turning	81
reflector, yellow		U	
safety sign	36	U.S. patents	
removing from		safety sign	37
storage	103	units of measurement	41
replacement parts	21, 41	V	
restrictor fitting		virtual switch box	87
safety sign	33		

W

wing lock pins	
installing	22
removing	23
wings to the center frame	
leveling	72
wireless blockage monitor	68
word to the operator	10

