

AIR TILL DRILL

ASSEMBLY, OPERATORS & PARTS MANUAL

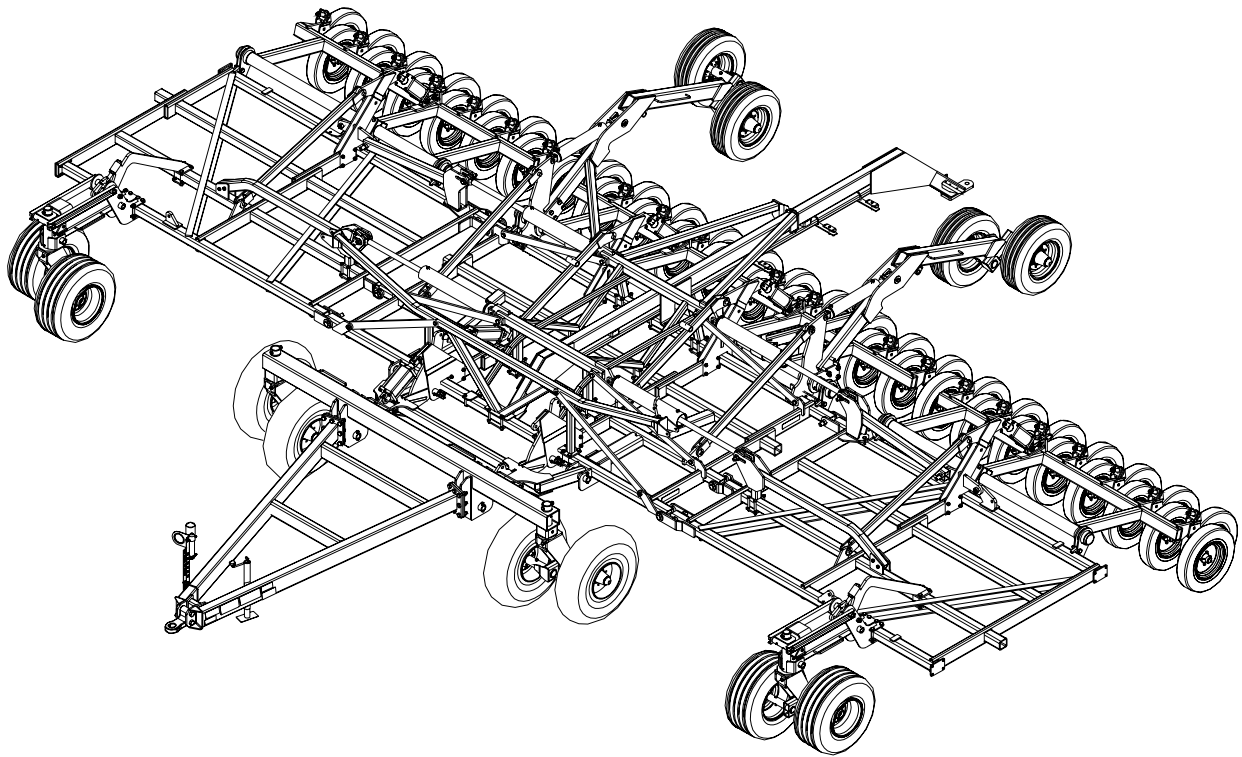

Serial # 457066 and up

Printed in USA (74285) 5/10

PERSONAL SAFETY IS IMPORTANT!

ALL PERSONNEL INVOLVED WITH THE ASSEMBLY AND/OR OPERATION OF THIS EQUIPMENT MUST BE INFORMED OF PROPER SAFETY PROCEDURES. OPERATOR'S/ ASSEMBLY MANUALS PROVIDE THE NECESSARY INFORMATION. IF THE MANUAL IS LOST FOR A PARTICULAR IMPLEMENT, ORDER A REPLACEMENT AT ONCE. OPERATOR'S AND ASSEMBLY MANUALS ARE AVAILABLE AT NO CHARGE UPON REQUEST.

This Safety Alert symbol means **ATTENTION! BECOME ALERT YOUR SAFETY IS INVOLVED!**



The Safety Alert symbol identifies important safety messages on your Wil-Rich DOT Disk and in this manual. When you see this symbol, be alert to the possibility of personal injury or death. Follow the instructions in the safety message.

Why is SAFETY important to you?

3 Big Reasons

Accidents Disable and Kill
Accidents Cost
Accidents Can Be Avoided

SIGNAL WORDS:

Note the use of the signal words **DANGER**, **WARNING** and **CAUTION** with the safety messages. The appropriate signal word for each message has been selected using the following guidelines:

DANGER

An immediate and specific hazard which **WILL** result in severe personal injury or death if the proper precautions are not taken.

WARNING

A specific hazard or unsafe practice which **COULD** result in severe personal injury or death if the proper precautions are not taken

CAUTION

Unsafe practices which **COULD** result in personal injury if proper practices are not taken, or as a reminder of good safety practices.

Remove all wires and arrange the parts conveniently.

NOTE: Always wear safety glasses or goggles and be careful when cutting wires and steel bands as they are under tension and will spring back when cut.

Wherever the terms "left" and "right" are used, it must be understood to mean from a position behind and facing the machine.

Lubricate all bearings and moving parts as you proceed and make sure they work freely.

Loosely install all bolts connecting mating parts before final tightening.

When tightening bolts, they must be torqued to the proper number of foot-pounds as indicated in the table unless specified. It is important that all bolts be kept tight.

On new machines, all nuts and bolts must be rechecked after a few hours of operation.

	GRADE 2		GRADE 5			GRADE 8	
TORQUE IN FOOT POUNDS							
BOLT DIA	3/8	1/2	5/8	3/4	7/8	1	
HEX HEAD	9/16	3/4	15/16	1-1/8	1-5/1	1-1/2	
UNC GR2	18	45	89	160	252	320	
UNC GR5	30	68	140	240	360	544	
UNC GR8	40	100	196	340	528	792	
UNF GR2	21	51	102	178	272	368	
UNF GR5	32	70	168	264	392	572	
UNF GR8	48	112	216	368	792	840	

CAUTION

TO AVOID INJURY AND/OR MACHINE DAMAGE:

- Refer to Operator's Manual for safety instructions.
- Do not stand or climb on machine when operating.
- Use clean hazard flashers and SMV sign when transporting.
- Observe highway traffic regulations.

23325

ASSEMBLY INFORMATION

When replacing a bolt, use only a bolt of the same grade or higher. Except in shear bolt applications, where you must use the same grade bolt.

Bolts with no markings are grade 2

Grade 5 bolts furnished with the machine are identified by three radial lines on the head.

Grade 8 bolts furnished with the machine are identified by six radial lines on the head.

All U-bolts are grade 5.

THIS SYMBOL USED TO CALL YOUR ATTENTION TO INSTRUCTIONS CONCERNING YOUR PERSONAL SAFETY. BE SURE TO OBSERVE AND FOLLOW THESE INSTRUCTIONS

Common Abbreviations

ASSY	Assembly
BLD	Blade
BLT	Bolt
BRKT	Bracket
CTR	Center
CP	Cup Point
(FF)	Female Female
GR	Grade of Bolt
HD	Heavy Duty
HDWE	Hardware
HLK	Hecial Lock Washer
LH	Left Hand
(MF)	Male Female
MF	Main Frame
MTG	Mounting
NC	National Course Thread
NF	National Fine Thread
NLK	Nylon Lock Nut
NPT	National Pipe Thread
PLW	Plow
RH	Right Hand
(OPT)	Optional
SST	Stainless Steel
TA	Tandem
TBP	Top Bypass
W/	With
W/O	Without
WLDMT	Weldment
WSHR	Washer

TO THE OWNER

This 4060 AIR TILL DRILL has as standard equipment a clearance lighting package. If your unit is not equipped with this package, it can be ordered by contacting your local dealer or the factory directly.

It is the responsibility of the user to read the Operator's Manual and comply with the safe and correct operating procedures as pertains to the operation, lubrication and maintenance of the product according to the information outlined in the Operator's Manual.

If this machine is used by an employee or is loaned or rented, make certain that the operator(s), prior to operating, is instructed in safe and proper use and reviews and understands the Operator's Manual.

The user is responsible for inspecting his/her machine and for having parts repaired or replaced when continued use of this product would cause damage or excessive wear to the other parts. The word NOTE is used to convey information that is out of context with the manual text; special information such as specifications, techniques, reference information of supplementary nature.

When in need of parts, always specify the model and serial number. Write this number in the space provided.

MODEL NO: _____

SERIAL NO: _____

MODIFICATIONS

It is the policy of this manufacturer to improve its products whenever possible and practical to do so. We reserve the right to make changes, improvements and modifications at any time without incurring obligation to make such changes, improvements on any equipment sold previously

All equipment is equipped with a serial number tag to track the unit. The serial number tag is located on the inside of the outer frame tube in the front left corner of the main frame (SEE BELOW). Use the information on this tag to identify when ordering parts or requesting information

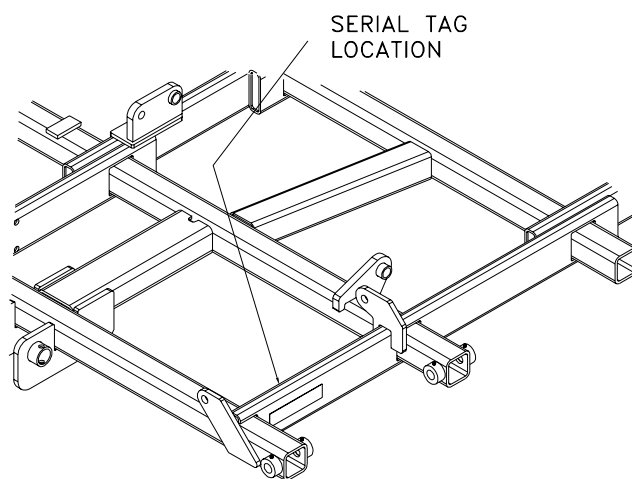

UNLESS SPECIFIED ALL BOLTS ARE SECURED WITH TOP-LOCK LOCK NUTS

PART NO.	DESCRIPTION
88125	NUT HEX 1-8NC 5Z
88141	NUT JAM 1-8NC 5Z
88430	NUT 2POSLK 1-1/4-7NC 5Z
88622	NUT JAM 1-1/4-7NC 5Z
88658	NUT TOP LK 1-8NC 5Z
88659	NUT TOP LK 3/8-16NC 5Z
88661	NUT TOP LK 1/2-13NC 5Z
88665	NUT TOP LK 3/4-10NC 5Z
88831	NUT TOP LK 7/8-9NC 5Z
88845	NUT TOP LK 5/8-11NC 5Z

UNIT ASSEMBLY PROCEDURE

Read and review all assembly instructions before starting assembly of this unit.

This unit will be packed in a condensed format, usually on a packaging skid. This package may be very heavy and will require the use of some type of fork truck or material handling device to unload the package and break down the parts. Because the various frame components are arranged in a vertical manner any handling equipment must be able to safely lift and position to a height of 12 ft.

Once bundled skids have been properly delivered and positioned in a hard, flat and level area the various frame parts can be removed. **NOTE: the components are banded together in the bundling process and these bands provide the structure to maintain the package. Cutting or removing these bands can cause the components to tip or fall- make certain that the parts are properly supported before removing any bands.**

Once the bundle has been broken down into the individual components locate the main frame of the unit. Assembly of this unit (page 18) will require some type of stands to support the components during assembly. These stands should be at least 36 in. tall and of adequate strength to support the components. Number noted (XX) indicate page numbers to reference while assembling.

Position the main frame on the work stands in the center of the assembly area. **NOTE: HARDWARE TO SECURE THE COMPONENTS IS NOTED IN THE ASSEMBLY INFORMATION. UNLESS SPECIFIED ALL NUTS ARE TOP LOCK NUTS. WHEN ASSEMBLING THE COMPONENTS DO NOT TIGHTEN THE LOCK NUTS UNTIL ALL PARTS HAVE BEEN ASSEMBLED. TIGHTEN NUTS TO HOLD PARTS IN POSITION BUT STILL ALLOW ADJUSTMENTS TO BE MADE.**

Position and support the inner wings level with the main frame (22-29) and secure with the noted hardware. Mount the outer wing hinge components (24-25) to the inner and outer wing and attach the outer wing to the inner wing. (26-30) Support all frames with work stands.

Mount the shank assemblies (38,51-54) in the positions shown. Mount any required stubs needed to locate all the shank assemblies. **NOTE: it may be necessary to shift the shanks laterally to allow clearance for the shank or springs to clear. There are also a number of shanks which mount to frame components and do not use the standard top plate.**

Mount the pre-assembled wing lift assemblies to the front frame tubes as located on the shank spacing chart (51-54).

Locate the main frame and wing packer towers and attach to the rear of the frame, secure with the mast tubes noted (22,23,26-31). Assemble the center packer mount to the center packer lift bracket and secure with axle clamps and hardware (34). Slide the inner lift axle pivots onto the end of the center packer mount, slide the rear lift mast into position shown. Slide the center packer hanger onto the ends of the center packer mount and secure.

Attach the wing packer mounts in the same manner as noted above (22,23,26-31). If unit is equipped with a rear hitch position in the center of the frame at this point and secure as noted (37).

Position the mainframe anchor assembly (18) on the top tubes of the main frame and secure. Further tie the mainframe anchor assembly to the main frame with the truss straps. Position the front wing rest/lock and secure. Locate the front and rear wing fold anchors and secure to the main inner wings. Attach the packer lift anchors (34), center in the adjustment slot, and adjustment bolt to all rear packer sections. Secure the front lift masts to the front main frame tube (32). Place the inner and outer wing rests as noted (,22,23,28,29) and loosely secure.

Locate and attach the Main Lift Hitch and related parts to the front of the main frame with the pins provided (20), secure with noted hardware. Assemble the main hitch cross and main hitch as shown, insert the front axle pivots, hubs and spindles and tires. **Do not attach the main hitch cross to the main lift hitch at this point.**

Position and attach the left and right rear lift axles to the lift axle pivots (34) as shown and secure. Insert hubs & spindles and rims and tires.

HYDRAULIC SYSTEM ASSEMBLY

The drill portion of this unit requires 3 hydraulic circuits to properly operate.

MAIN LIFT CIRCUIT

The main lift circuit is used to raise and lower the complete unit. It consists of a set of 8" stroke sequencing cylinders of varying diameter which, when properly connected and adjusted, will move the unit in a level manner. Unit operating depth is maintained by using stroke control collars of varying length on each lift cylinder (see operating instructions for more information).

Locate the lift cylinders and move to the lift axle areas. Refer to cylinder location instructions (43) to assemble the cylinders to the lift anchors, rear packer and main lift hitch. Cylinders are mounted with the rod ends up, secured with the pins noted or with the pins that are supplied in the cylinder boxes. Locking roll pins or cotter keys can be used to secure the pins. Locate the cylinder stop collar packages and clip to the storage rods provided at each cylinder location.

Locate the appropriate hydraulic hoses and position in the general areas of the unit as shown in the hose routing instructions (45-50). Install noted fittings in all cylinders in the circuit. As shown this system requires that the hoses connect the cylinder's in the correct sequence. Hoses are routed from the tractor to the base end of the largest cylinders, from the rod end of that cylinder to the base end of the next smaller diameter cylinder, etc.

HOSE ROUTING/CLAMPING

Hose should be generally routed as shown in the routing instruction. Since there are many variables to the routing of hoses it is recommended that hoses be routed along frame members where possible. Special attention should be paid to routing hoses away from potential pinch points when folding wings or when working. Note the need for more hose at the hinge points, route the hoses so there is additional length to move as components move. Loosely secure hoses with the plastic ties provided, cinch tight after final assembly.

WING FOLD CIRCUIT

The inner and outer wings are operated by large 5" hydraulic cylinders. Refer to the cylinder location instructions for proper orientation of the cylinders (42). Attach the base ends of the outer wing fold cylinders with the bolts or pins noted. Position a wood block spacer under the cylinder to hold the rod end of the cylinder above the outer wing fold linkage attach point. Attach the base ends of the main wing fold cylinders to the main frame anchor assemble as shown. Support the end of the cylinders to allow room for the rods to fully extend without contacting any frame parts.

Locate the required hoses for this circuit, connect the circuit as shown, route and loosely secure the hose with the plastic ties provided.

TRANSPORT LIFT CIRCUIT

There are two sets of lift cylinders that are used to lift and hold the unit in the transport position. These cylinders are connected in a simple circuit as noted (42). Attach the base end of the 4x12 cylinders to the anchor on the main frame and the rod end to the front lift mast. Attach the base end of the 4x16 cylinders to the rear lift mast and support the cylinder with a block to allow full extension without contacting machine elements. Locate the required hoses for this circuit, connect the circuit as shown, route and loosely secure the hose with the plastic ties provided.

HYDRAULIC SYSTEM CHARGING

Once all hydraulic circuits have been assembled as noted and the hoses have been attached it is important to properly charge the system.

NOTE: THE SYSTEMS ON THIS UNIT WILL REQUIRE A LARGE AMOUNT OF HYDRAULIC OIL TO FULLY CHARGE AND PURGE. MAKE CERTAIN THE SYSTEM USED TO CHARGE THE CIRCUITS HAS ADEQUATE HYDRAULIC PRESSURE (2700 PSI MINIMUM) AND CAPACITY. OIL MAY NEED TO BE ADDED TO THE PUMP RESERVOIR TO COMPLETE CHARGING. ALL CIRCUITS MUST BE FULLY CHARGED BEFORE LIFTING OR FOLDING THIS UNIT

CHARGING MAIN LIFT CIRCUIT

Sequencing systems require that all cylinders be fully charged with oil. This is accomplished by forcing oil into the main or master cylinder, in this case the 5x8 cylinder located on the front hitch. When the cylinder is charged with oil and fully extended it will move into a bypass mode, oil will move out of the rod end port and to the next cylinder in the sequence. That cylinder will extend into bypass and move oil to the next, etc. This initial process can take a considerable amount of time. While charging the main lift system make certain that all cylinders in the circuit are able to fully extend without contacting any frame components. This is the reason the front pivot axles and main hitch cross should not be attached.

Once both sides of the units main lift cylinders have extended fully, retract the cylinders. All cylinders should retract in sequence. Fully extend the cylinders again and check to ensure all cylinders are purged and fully extended. Once the main lift circuits have been charged the front wheel lifts can be completed as shown (32). Attach the front hitch cross with the pins and hardware required (20).

CHARGING WING FOLD CIRCUIT

Connect the wing fold circuit to the oil supply and apply pressure. Again the main frame fold cylinders will slowly extend to full extension or all cylinders may extend depending on the pressure required to extend. Make certain that the cylinders do not contact machine parts while extending and retracting.

NOTE: all wing fold cylinders have an integral restrictor in the rod end for safety. This restrictor can make the charging of the system seem slow but is necessary. All wing fold cylinders must be fully charged and cycled before connecting the rod ends to the lift brackets.

Once all cylinders have been charged, fully retracted and fully extended, attach the rod ends to the noted anchor points (22,23,26,31).

CHARGING TRANSPORT LIFT CIRCUIT

As with the wing fold circuit, support the cylinder while extending and charging. Once the circuit has been charged and cycled, attach the rod ends of the cylinders to the appropriate anchor points and secure (26-31).

REAR PACKER ASSEMBLY

The main components of the rear packers are pre-assembled. Locate these assemblies and move to the rear of the unit. It will require that the top pivot bolt be removed to attach the packer pivots to the rear packer mounts. Disassemble, mount to the rear packer mounts as shown and reassemble. Insert the packer pressure spring and secure with the hardware noted. Initially tighten the spring bolt to lightly compress the spring.

Mount the packer wheels and securely tighten all mounting bolts. Refer to the operational information for additional information on packer settings.

OPERATIONAL INFORMATION

INITIAL/PRE-FIELD SETTINGS

Once the unit has been fully assembled and before the unit is folded for transport check to ensure that all hardware has been properly tightened to specifications noted. Check to ensure that there are no loose parts or tools anywhere on the unit.

Attach the unit to the tractor that will be used with the unit and connect all hoses. Raise the unit to full height with the main lift cylinders and hold the lever to purge the system. Move to a flat area, preferably a level concrete surface and position the unit in an open area. Activate the transport lift circuit to raise the rear transport wheels so that the rear of the unit is carried by the rear packer wheels.

Make certain that all points or attachments are mounted on the unit before doing any pre-field settings. **NOTE: Any settings completed in the yard may need to be altered once the unit is in field use. Pre-field settings will make the final field settings less challenging.**

Once the main lift system has been purged and sequenced lower the unit down so the shanks are 2" to 3" above the ground as shown below. Measure the distance to the ground from a point of a shank on the front rank of the unit. Pick a shank on the outside of the main frame. Measure from the same point of a shank on outside rear of the unit.

If the unit is not level front to rear an adjustment will need to be made to the rear packer anchor point. Loosen the two anchor bolts to allow the anchor to slide. Use the adjust bolt to raise or lower the rear of the main frame to level the unit.

Check the side to side level of the main frame in a similar manner. Adjust the remaining main frame rear packer anchor to level the unit side to side.

To relieve the pressure on the adjustment anchors to make the adjusting easier, lower the unit to the ground to take the load off the anchors. Adjust as required, fully extend the cylinders to properly sequence the system and lower to the unit so the shanks are 2" to 3" off the ground. Measure as before and continue to fine tune the unit level.

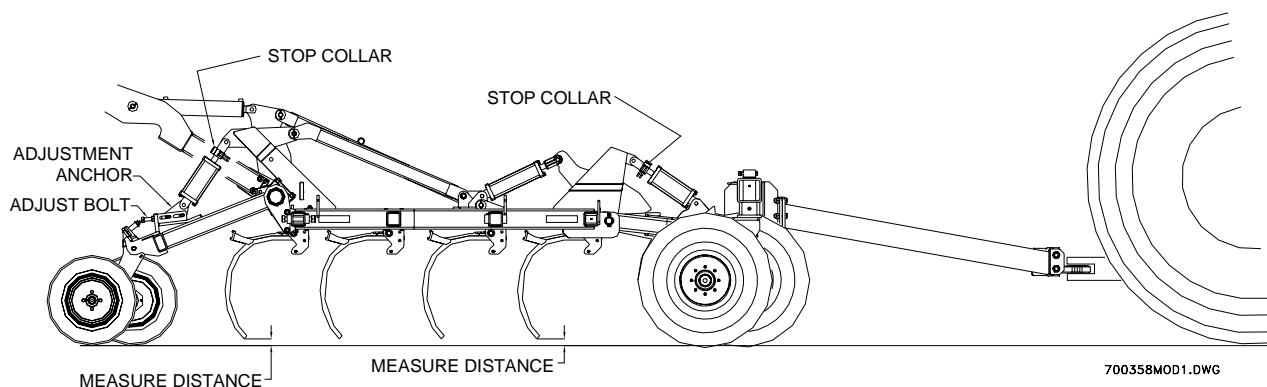

PRE-FIELD SETTINGS INNER AND OUTER WINGS

Check the front to rear level of the inner wings. As noted below the measured distance between the shank and the ground should be the same as the main frame. To adjust the level front to rear both the front lift wheel and rear packer can be adjusted. Check the distance at the front outside shank location on the wing versus the height of the main frame. If the front of the wing needs to be altered, loosen the jam nuts on the front adjust screw and adjust as required. Once the front of the wing is at the same depth as the main frame, lock the front into position. Measure the rear shank height and adjust the rear packer adjust anchor as required.

Repeat the same procedure for the outer wing and wings on other side of the main frame, levelling the wings front to rear and setting the wing height to the main frame.

As with the main frame, lower the unit to relieve the load on the various anchors to allow easier adjustment,

Once the adjustments to the various anchors have been completed there should be minimal need to readjust these settings. When the unit has been moved to the field and dropped to the seeding depth it is important to recheck the front to rear level and depth of each section. Variations in soil type and loading will effect the operational depth and readjustments may be required.

The adjustments noted above are to level the unit. **To control the seeding depth the stop collars on each lift cylinder must be changed.** A full set of stop collars of varying thickness is provided for each lift cylinder. Use these stop collars to set the seeding depth of the unit. If the seeding depth is too deep, stop collars need to be added to each cylinder. **The cylinders have been sized to allow the addition or removal of the same thickness of stop collars from each cylinder to control depth of seeding.** For example: if the unit is seeding deep all cylinders would have a 1/4" stop collar added. As the unit is cycled it may require that the lift system be re-sequenced. Raise the unit and hold the cylinders in the extended position until all cylinders have been purged.

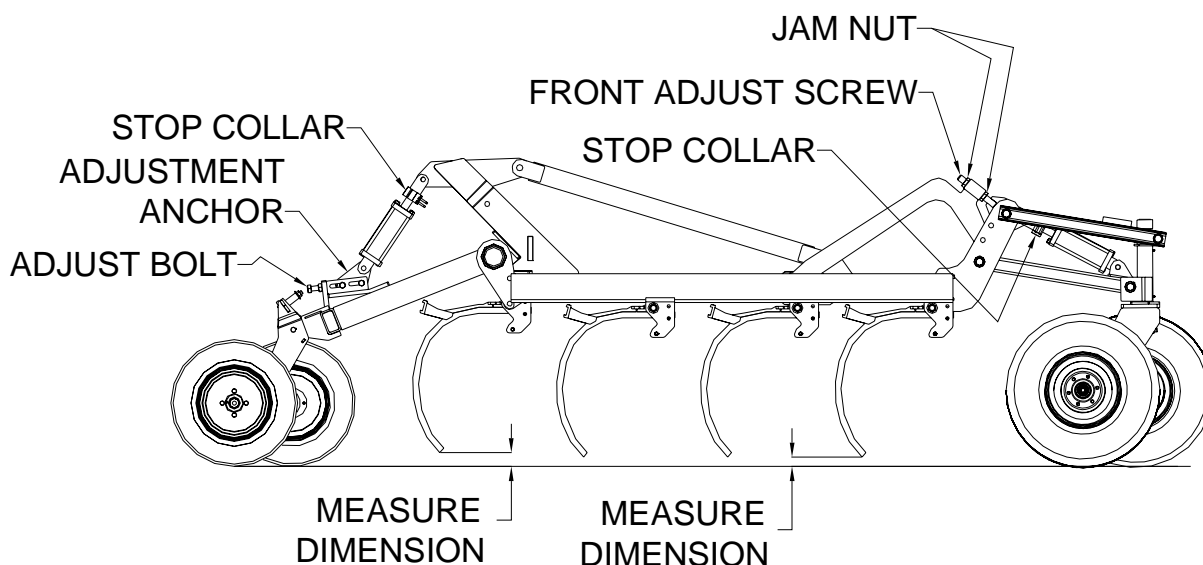

WING FOLDING/UNFOLDING

After the unit has been charged and levelled it can be winged up to the transport position. Make certain that the unit is hitched to a tractor and setting on a level surface when folding the wings. If possible move the unit to an area where the ground is not as hard but has a loose composition. Move all personnel away from the path of the wings but pay attention to the components when folding.

Before folding the wings, raise the unit to full height with the main lift circuit. Activate the transport circuit and extend the front and rear lift cylinder fully. Place the channel locks into position on the transport cylinders.

NOTE: Channel locks must be locked in position on all (4 ea) transport lift cylinders before attempting to fold the wings or transporting.

Once channel locks are in position, activate the wing fold circuit. All cylinders should began to retract and start folding the outer wings. When folding for the first time pay attention to the movement of hydraulic or feed hoses, it may require that hoses be moved to prevent kinking or pinching. As the outer wings began to fold the packer wheels at the outer hinge point may skid. This should not be a problem when folding the unit in loose ground conditions. Skidding can be reduced by slowly moving forward with the unit as the wings are folded. Forward movement is only required when the wing packer wheels are skidding.

NOTE: Do not allow personnel to walk under a wing at any time while it is folding or unfolding. Front gage wheels on the wings can abruptly rotate as the wings are folded, do not allow any personnel to be in the wing fold area or on the unit.

As the outer wings fold over the main wings check to ensure that the wing rest contacts and supports the outer wing . Slightly raise the outer wing and adjust wing rest if required.

Once both outer wings have been folded, continue to fold the inner wings. These wings should fold to a vertical position. As the wings approach the vertical position activate the main lift circuit and pull the packer wheels and front lift wheels up. This is necessary to allow clearance in the center of the unit and reduce the transport width. The outer wing should rest on the inner wing rest mounted on the mainframe. If contact is not made readjust the location of the rest.

The front wing rest has provisions to lock or pin the wing for transport. This is not required on the 60 ft. unit as the design of the wing fold does not require a lock.

NOTE: On 40 ft. units with a single wing the main wing must be locked. Insert the locking pin in the clevis on the front wing lock. Make certain that the wing is unlocked before attempting to unfold the wings. Approach the wings from the front when locking or unlocking the wings, never go into the wing fold path to lock or unlock the wings.

To unfold the wings reverse the process. As the inner wing approaches the ground, activate the main lift circuitry and lower the packer and front lift wheels. The main lift and rear packer wheels must be on the ground to support the wings when they touch down. On units with outer wings (60 ft. unit) the wing fold circuitry has a sequence valve to properly unfold the wings. This valve is designed to prevent the outer wings from moving before the main wings have completely unfolded. If the outer wing wants to move excessively before the inner wing is unfolded, adjust the sequence valve by loosening the locking nut and turning the adjustment screw clockwise. Adjust as required and secure setting with the locking nut.

TRANSPORTING UNIT

The 4060 Air Till Drill should be fully folded with the wings locked (40 ft. unit) before transporting. **NOTE: This unit should never be transported without the transport or channel locks installed in the front and rear transport cylinders.** Store the channel locks on the storage bars located on the front cross bar and rear lift axles.

When hitched to the tractor and with a seeder cart attached to the rear hitch the whole machine is quite long. Care must be taken when transporting. When turning the seeder unit will rotate about the rear transport wheels requiring a large turning radius. Never transport the complete unit at high speeds during field use or on the highway. Make certain the tractor is properly weighted to handle the heavy pull load. Use care when moving across uneven ground or poor roads. Do not transport at unsafe speeds on narrow, rough roads. Do not carry the unit off the side of the road where the right side carrying wheels are off the main roadbed. If it is necessary to move off the road to allow traffic to pass, pull off the road slowly or stop and allow traffic to pass.

Do not back the unit up when attached to the seeder supply tank. With the wings folded and no tank is attached it is possible to carefully back the unit a short distance. **NOTE: Never unhitch the unit from the tractor with the main wings folded or with the main frame carrying wheels rotated to the front.**

STORAGE

Unit should be stored inside and unfolded if possible. Park the unit in a flat, level area. Unfold the wings to remove the load from the main frame carrying wheels. **NOTE: Never remove the main transport channel locks and lower the unit to the ground with the main wing folded.**

If the unit is parked on a soft surface place support under the lift wheels to prevent sinking into the ground. When storing the unit at any time, if hitched to a tractor or not, always relieve the pressure to the wing fold circuit. This can be accomplished by using the float circuit of the tractor. Move the hydraulic lever to the float position to relieve pressure in the wing fold circuit before turning off or unhitching the tractor.

FIELD OPERATIONS

Following the completion of the assemble and pre-field settings the unit can be attached to the rear seed supply system. Refer to the provided information on the supply system for setup and operational information on that portion of the seeding system.

Enter the field and unfold the main/ outer wings of the unit. Pressurize the main lift hydraulic circuit to sequence the main lift cylinders. Activate the transport lift circuit, remove and store the channel locks. Fully retract the transport cylinders. Pull forward with the air system engaged and lower the unit into the ground. Set the initial depth of operation without using any stop collars. Stop and check the depth of operation of the main frame. Install the required amount of stop collars in the main frame cylinders to place the unit at the desired working depth. The cylinders should be fully retracted and held by stop collars. Check the front and rear and side to side depth of operation and adjust the rear packer adjustment anchor or front lift axles as noted in the PRE-FIELD SETTINGS instructions.

Once main frame is set to desired depth, raise the unit to full height and hold for 1 minute. Place the same combination of stop collars in all remaining lift cylinders. Lower the unit into the ground while moving forward and stop. Check the depth and level of the wings and readjust as noted in the PRE-FIELD SETTINGS if required.

If main frame or wing depth needs to be changed to be level, do not add or remove stop collars from that cylinder. Readjust the various adjustment anchors.

With a sequencing lift system if one cylinder is stopped by use of additional stop collars all cylinders in the circuit will stop and the depth settings on the remaining cylinders in the circuit will be impacted. **All lift cylinders should use the same combination or amount of stop collars.**

Move through the field and observe the general operation of the unit. Check the movement of the rear packers arms. If there is excessive vertical movement or bouncing of the packer wheels it may require that the packer compression spring be tightened. It is generally best to have limited pivoting of the packer arms when seeding. Arms should only rotate when encountering a large soil mound or rocks. Tighten the lock nut on the packer spring to increase the holding force.

As with all machinery it will be necessary to check the tightness of all hardware after 4-6 hours of use. As the various components seat there will be parts that need to be adjusted. Hardware that is retaining parts that do not rotate or move should be checked after the first day of use and weekly after that. Parts such as packer wheel pivots or parts that need to wear in or seat should be checked and adjusted more frequently.

Refer to the GREASING information on Page 55-56 for grease locations and frequency.

TIRE INFLATION

The front lift and rear transport tires (31x13.5, 12 ply) should be inflated to 60-65 PSI. If there appears to be sidewall flex in the large front center lift tires the pressure can be increased to 80-85 PSI.

The rear packer tires can be set at 15-35 PSI depending on packing and load requirements. A lower setting will allow the tires to pack a somewhat wider area and shed mud, but there must be sufficient tire pressure to limit sidewall flex. Set initial pressure to 15 PSI and increase or decrease as conditions dictate.

CAUTION

TO AVOID POSSIBLE INJURY:

- **Always lower implement to the ground for servicing or when not in use.**
- **Never allow anyone to ride on implement.**
- **Keep everyone clear of tractor and implement while in use or while tractor is running.**

31926

UNLESS SPECIFIED ALL BOLTS ARE SECURED WITH TOP-LOCK LOCK NUTS

PART NO.	DESCRIPTION
88125	NUT HEX 1-8NC 5Z
88141	NUT JAM 1-8NC 5Z
88430	NUT 2POSLK 1-1/4-7NC 5Z
88622	NUT JAM 1-1/4-7NC 5Z
88658	NUT TOP LK 1-8NC 5Z
88659	NUT TOP LK 3/8-16NC 5Z
88661	NUT TOP LK 1/2-13NC 5Z
88665	NUT TOP LK 3/4-10NC 5Z
88831	NUT TOP LK 7/8-9NC 5Z
88845	NUT TOP LK 5/8-11NC 5Z

FULL UNIT OVERVIEW - 60FT UNIT

This page shows an overview of the complete unit as a reference guide to understanding the general layout of the unit. Please refer to the individual assembly instructions for specific information.

Refer to the front cover for a general overview of the 40ft unit.

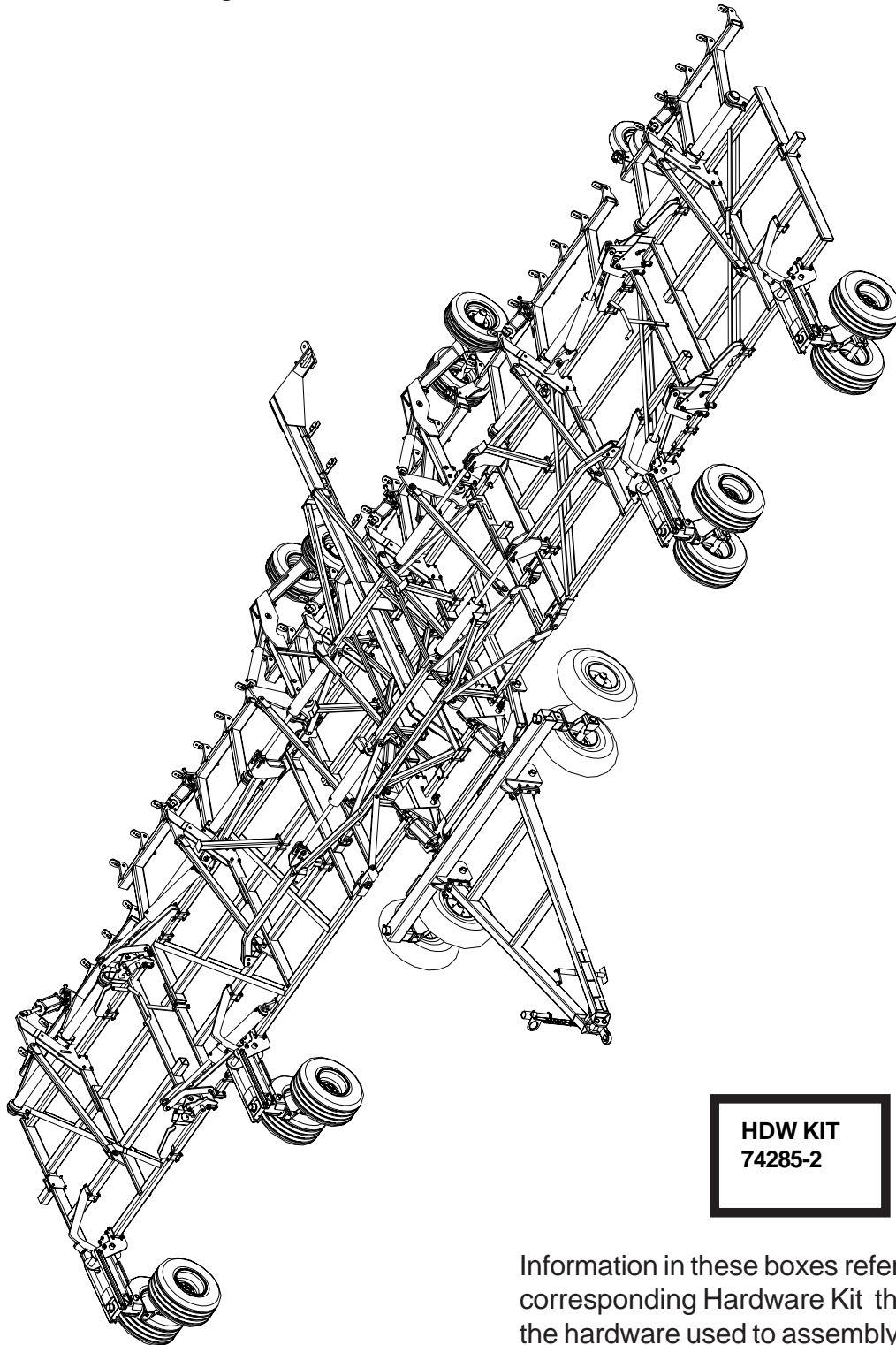

Information in these boxes reference the corresponding Hardware Kit that contains the hardware used to assembly the portion of the unit noted on that page.

SAFETY

Safety decals appear at various locations on your machine. The decals are provided for your safety and must be kept clean. Replace any decal that becomes worn, damaged, painted over or otherwise difficult to read. Replacement decals are available through you Wil-Rich dealer.



BEFORE OPERATING

Use extreme care when making adjustments.

When working under or around the machine always lower shanks to the ground. It is not recommended to set points with cast inserts on cement as the impact may break the casting. We recommend setting blocks under the shank to keep points from resting on cement. After servicing, be sure all tools, parts, or service equipment is removed from the machine.

Make sure there is no one near the machine before or during operation.

DURING OPERATION

Reduce speed when cornering on field ends and when operating on or across dead furrows.

Do not attempt to remove any obstruction while the machine is in motion.

Use extreme care when operating close to ditches, fences or on hillsides.

No one other than the operator should ride on the tractor.

Before and during operation be sure no one is on or around the implement. Serious injury can result from improper use.

ON HIGHWAY OPERATION

Comply with your local laws governing highway safety when moving machinery on a highway.

Reduce road speed on corners.

Drive at a responsible speed to maintain complete control of the machine at all times.

An S.M.V. emblem and safety lights must be used at all times while traveling on public roads.

MAIN ASSEMBLY

PART NO.	DESCRIPTION	QTY
22290	L-BOLT 5/8 IN FOR 4 SQ TUBE	2
233552	WING REST SLIDE TUBE	2
234764	HYD CYL 4" X 12" (BLACK)	2
234811	1/2X4 BENT PIN W/HAIRPIN	2
240438	MAIN FRAME - ATD	1
240529	ASSEMBLY	1
241530	TRUSS STRAP	4
241536	TRUSS STRAP	2
241538	TRUSS STRAP MOUNT	1
241634	INNER WING REST - ATD	2
241640	12 INCH CHANNEL LOCK	2
241652	WING LOCK PIN (PLATED)	2
62271	FRAME PLATE (RED)	8
88110	NUT HEX 3/4-10NC 5Z	4
88145	BLT-U 5/8-11NCX4X5-1/4 Z	4
88181	BLT HEX 1-8NCX7 5Z	2
88277	3/4ACT) Z	2
88295	BLT HEX 5/8-11NCX6 5Z	36
88312	BLT HEX 1-8NCX5 5Z	2
88352	PIN SPRLK 3/16X3-1/4 PRLS6 Z	4
88393	BLT HEX 1-8NCX2-1/2 5Z	6
88604	BLT HEX 3/4-10NCX2 5Z	4
89359	BLT HEX 1X8NC X 8 8YZ	2

FRONT HITCH ASSEMBLY

**HDW KIT
74285-2**

IF FRONT OF MAIN FRAME NEEDS TO BE RAISED SET WITH NOTCH UP AS SHOWN. MAKE CERTAIN BOTH ANCHORS ARE SET THE SAME.

NOTE: THIS IS A TWO POSITION ANCHOR, SET INITIALLY AS NOTED WITH INDEX NOTCH DOWN.

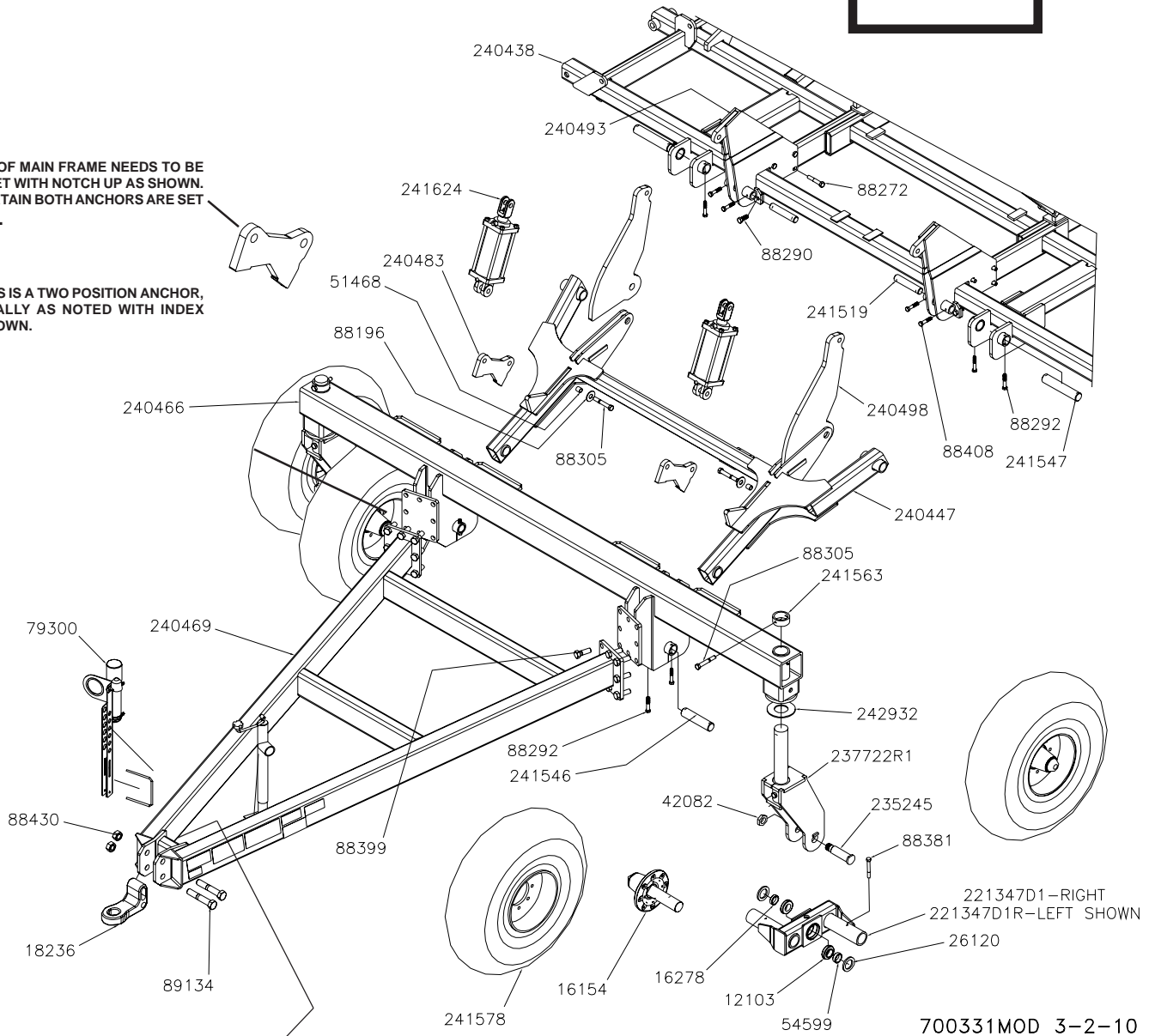

700331MOD 3-2-10

LOOP SAFETY CHAIN AROUND CENTER HITCH TUBE TO SECURE

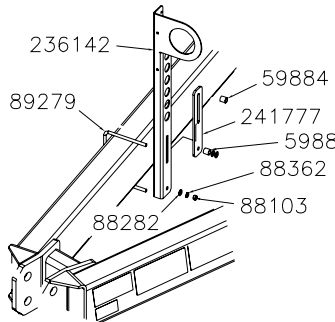

SECURE HOSE HOLDER TO THE INSIDE OF THE MAIN HITCH BY INSERTING 89279 THRU HOSE HOLDER, SHIM BETWEEN LEGS WITH BUSHING, BACKING PLATE & FLAT WASHERS PROVIDED IN MAIN HDW & HOSE HOLDER KIT.

UNLESS SPECIFIED, ALL HARDWARE IS SECURED WITH MATCHING LOCK NUTS

FRONT HITCH ASSEMBLY

PART NO.	DESCRIPTION	QTY
12103	BEARING CONE 1-3/4ID (25580)	4
16154	2-1/2IN HUB&SPINDLE ASSY(LG8210011)	4
16278	BEARING BUSHING	2
18236	CAST DUAL HITCH	1
221347D1	RIGHT 3X11 HD WALKING TANDEM	1
221347D1R	LEFT 3X11 HD WALKING TANDEM	1
235245	TANDEM PIN	2
237722R1	FRONT AXLE PIVOT -ATD	2
238225	40K SAFETY CHAIN	1
240438	MAIN FRAME - ATD	1
240447	MAIN LIFT HITCH - ATD	1
240466	MAIN HITCH CROSS	1
240469	MAIN HITCH - ATD	1
240483	FRONT LIFT ANCHOR	2
240493	FRONT LIFT MAST	2
240498	TRANSPORT ANCHOR	2
241519	PIVOT PIN	2
241546	FRONT PIN (PLATED)	2
241547	FRONT PIN (PLATED)	2
241563	TOP TUBE	2
241578	40 IN MAIN TIRE ASSY - ATD	4
241624	HYD CYL 5X8 SEQ	2
24415	JACK	1
26120	SEAL	2
42082	1-1/2NF HYDRA JAM LOCK NUT	2
51468	BUSHING	2
54599	WALKER BEARING BUSHING	2
236094	UTILITY POLE KIT 5 X 7	1
88131	WSHR FLAT 3/4(13/16X2ACT) Z	2
88272	BLT HEX 3/4-10NCX4 5Z	8
88290	BLT HEX 3/4-10NCX2 8YZ	4
88292	BLT HEX 5/8-11NCX3-1/2 5Z	8
88305	BLT HEX 3/4-10NCX5 5Z	4
88381	BLT HEX 5/8-11NCX4-1/2 5Z	4
88399	BLT HEX 1-8NCX3 5Z	16
88408	BLT HEX 5/8-11NCX3 5Z	4
88430	NUT 2POSLK 1-1/4-7NC 5Z	2
89134	BLT HEX 1-1/4-7NCX7 5Z	2
89279	BLT-U 3/8-16NCX7X6-1/4 Z	1
236142	FORMED CHANNEL-HYD HOSE BRKT	1
241777	BACKING PLATE-ZINC	1
59884	3/4OD X .75 IDLER BUSHING	2
88103	NUT HEX 3/8-16NC 5Z	2
88282	WSHR FLAT 3/8(7/16X1ACT) Z	6

LEFT INNER WING ASSEMBLY - 40' & 60'

**HDW KIT
74285-3**

**DO NOT OVERTIGHTEN, BOLT
MUST MOVE IN ANCHOR SLOT**

SEE PAGE 32 FOR
PACKER ADJUST
COMPONENTS

CYLINDER PINS ARE
PROVIDED IN LIFT
CYLINDER BOXES

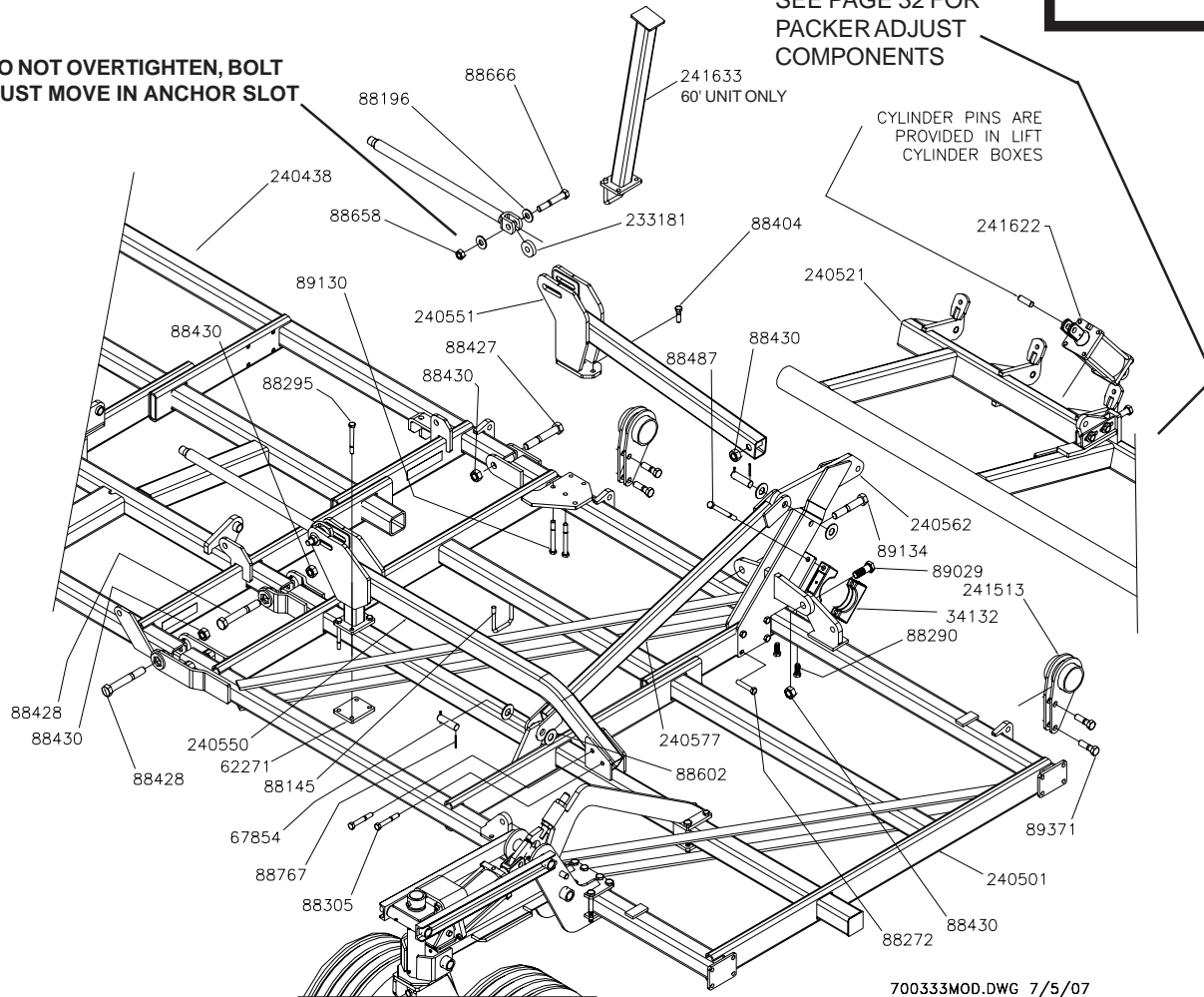

700333MOD.DWG 7/5/07

UNLESS SPECIFIED, ALL HARDWARE IS SECURED WITH MATCHING LOCK NUTS

PART NO.	DESCRIPTION	QTY	PART NO.	DESCRIPTION	QTY
233181	LINK DONUT	2	88272	BLT HEX 3/4-10NCX4 5Z	4
240438	MAIN FRAME - ATD	1	88290	BLT HEX 3/4-10NCX2 8YZ	2
240484	PACKER LIFT ANCHOR	1	88295	BLT HEX 5/8-11NCX6 5Z	4
240501	LEFT INNER WING - ATD	1	88305	BLT HEX 3/4-10NCX5 5Z	2
240521	LEFT INNER WING PACKER MOUNT	1	88404	BLT HEX 3/4-10NCX2-1/2 5Z	1
240550	FRONT WING ANCHOR	1	88427	BLT HEX 1-1/4-7NCX8 5Z	1
240551	REAR LIFT ASSEMBLY	1	88428	BLT HEX 1-1/4-7NCX9 5Z	2
240562	WING PACKER TOWER	1	88430	NUT 2POSLK 1-1/4-7NC 5Z	5
240577	WING MAST TUBE	1	88487	BLT HEX 3/4-10NCX8-1/2 5Z	4
241513	CENTER PACKER HANGER	2	88602	WSHR FLAT 1-1/4(1-3/8X3ACT) Z	4
241622	HYD CYL 4-1/2X8 SEQ	1	88666	BLT HEX 1-8NCX6-1/2 5Z	2
241633	OUTER WING REST - ATD	1	88767	PIN ROLL 1/4DIA X2-1/2 Z	4
34132	AXLE CLAMP ASSEMBLY	4	89029	BLT HEX 1-1/4-7NC X 4 5Z	1
62271	FRAME PLATE (RED)	1	89130	BLT HEX 3/4-16NCX6-1/2 5Z	2
67854	HEADLESS PIN(2) 1-1/4X3-23/32	2	89371	BLT HEX 1-8NCX3-1/2 8YZ	4
88145	BLT-U 5/8-11NCX4X5-1/4 Z	2	89134	BLT HEX 1-1/4-7NCX7 5Z	1
88196	WSHR FLAT 1(1-1/16X2-1/2ACT) Z	4	89373	BLT HEX 1-8NC X 8-1/2 8YZ	1

**HDW KIT
74285-3**

LEFT INNER WING ASSEMBLY - 50'

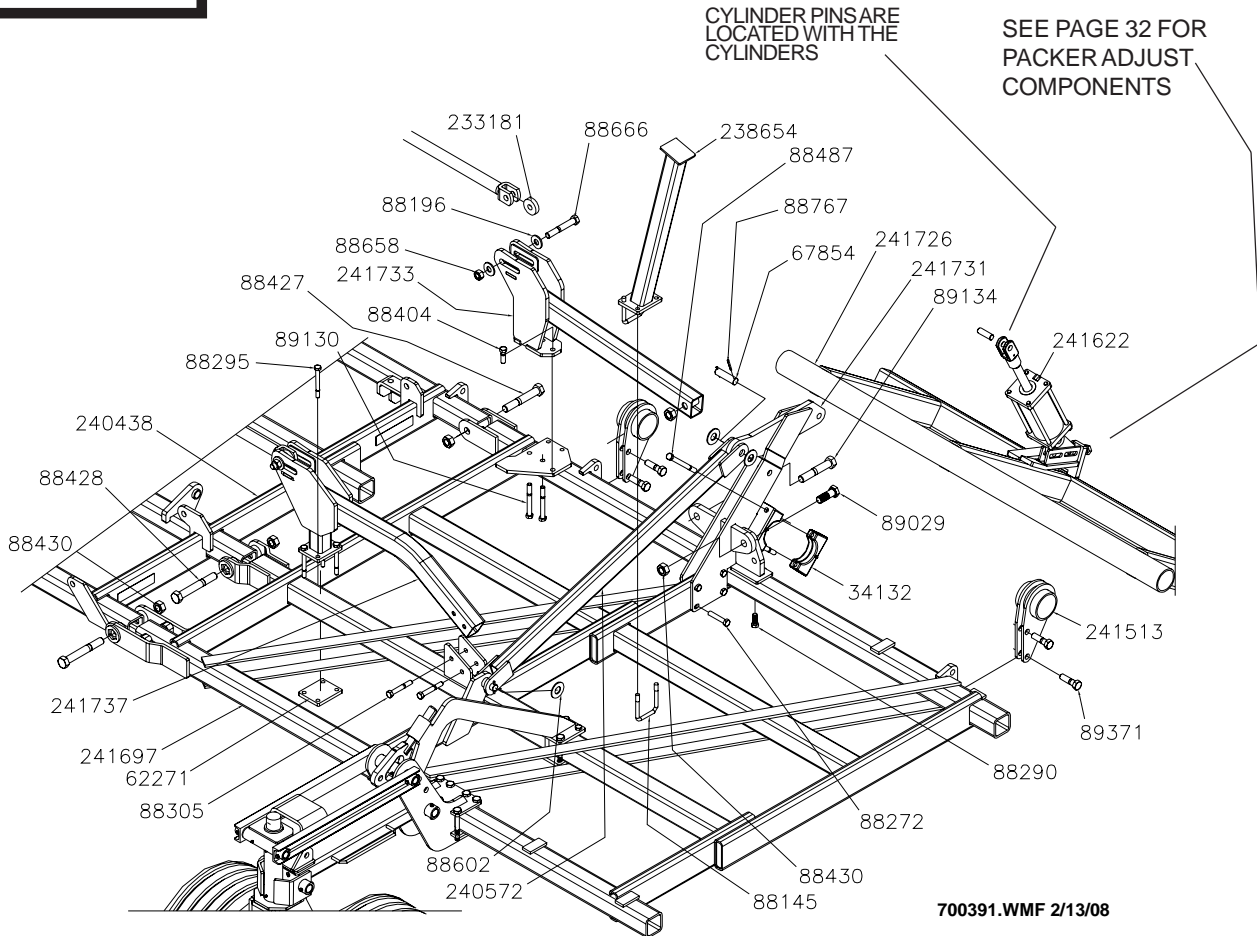

PART NO.	DESCRIPTION	QTY	PART NO.	DESCRIPTION	QTY
62271	FRAME PLATE	1	88290	BLT HEX 3/4-10NCX2 8YZ	2
233181	LINK DONUT (ZINC)	2	88295	BLT HEX 5/8-11NCX6 5Z	4
238654	OUTER SHORT WING REST - ATD	1	88305	BLT HEX 3/4-10NCX5 5Z	2
240438	MAIN FRAME - ATD	1	88404	BLT HEX 3/4-10NCX2-1/2 5Z	1
240572	LIFT MAST TUBE	1	88427	BLT HEX 1-1/4-7NCX8 5Z	1
241513	CENTER PACKER HANGER	2	88428	BLT HEX 1-1/4-7NCX9 5Z	2
241622	HYD CYL 4-1/2X8 SEQ	1	88430	NUT 2POSLK 1-1/4-7NC 5Z	5
241697	LEFT INNER ATD WING - SHORT	1	88487	BLT HEX 3/4-10NCX8-1/2 5Z	4
241726	LEFT INNER WING PACKER MOUNT	1	88602	WSHR FLAT 1-1/4(1-3/8X3ACT) Z	4
241731	SHORT INNER WING PACKER TOWER	1	88658	NUT TOP LK 1-8NC 5Z	2
241733	REAR LIFT ASSEMBLY - SHORT	1	88666	BLT HEX 1-8NCX6-1/2 5Z	2
241737	FRONT WING ANCHOR	1	88767	PIN ROLL 1/4DIAX2-1/2 Z	4
34132	AXLE CLAMP ASSEMBLY (RED)	4	89029	BLT HEX 1-1/4-7NC X 4 5Z	1
67854	HEADLESS PIN(2) 1-1/4X3-23/32	2	89130	BLT HEX 3/4-10NCX6-1/2 5Z	2
88145	BLT-U 5/8-11NCX4X5-1/4 Z	2	89134	BLT HEX 1-1/4-7NCX7 5Z	1
88196	WSHR FLAT 1(1-1/16X2-1/2ACT) Z	4	89371	BLT HEX 1-8NCX3-1/2 8YZ	4
88272	BLT HEX 3/4-10NCX4 5Z	4			

OUTER WING HINGE ASSEMBLY - 40' & 60'

RIGHT SIDE SHOWN
LEFT IS SIMILAR

**HDW KIT
74285-4**

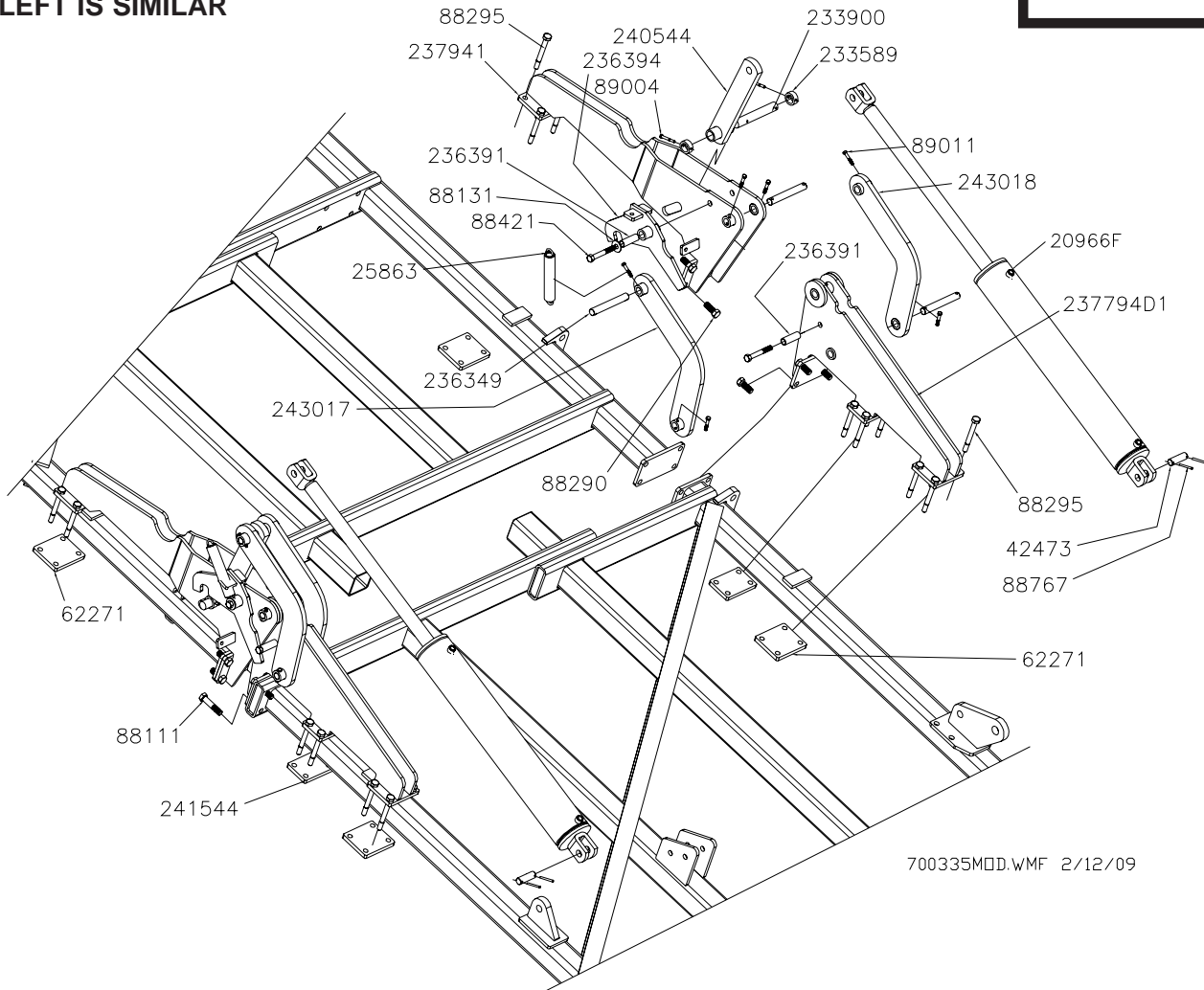

UNLESS SPECIFIED, ALL HARDWARE IS SECURED WITH MATCHING LOCK NUTS

PART NO.	DESCRIPTION	QTY	PART NO.	DESCRIPTION	QTY
237794D1	OUTER LINK	2	89011	BLT HEX 3/8-16NC X 2 5Z	12
20966F	HYD CYL 5X30 FGS #A519CY07	2	89004	BLT HEX 5/16-18NCX2-1/2 5Z	4
243018	OUTER FOLD LINK - REAR	2	88767	PIN ROLL 1/4DIA X 2-1/2 Z	4
243017	OUTER FOLD LINK - FRONT	2	88421	BLT HEX 3/4-10NCX4-1/2 5Z	4
241544	FRAME PLATE - PAINTED (241505)	2	88295	BLT HEX 5/8-11NCX6 5Z	24
240544	OUTER FOLD LINK	2	88290	BLT HEX 3/4-10NCX2 8YZ	12
237941	OUTER WING HINGE - ATD	2	88131	WSHR FLAT 3/4(13/16X2ACT) Z	2
236394	OUTER WING LATCH BRACKET	2	88111	BLT HEX 3/4-10NCX3-1/2 5Z	4
236391	PIVOT TUBE (ZINC)	4	62271	FRAME PLATE (RED)	4
236349	HINGE PIN (ZINC)	6	42473	HEADLESS PIN (H) (2) 1X2-3/8	2
233900	LOCK PIN	2	25863	SPRING	2
233589	PIN BUSHING (ZINC)	4			

**HDW KIT
74285-19**

OUTER WING HINGE ASSEMBLY - 50'

**LEFT SIDE SHOWN
RIGHT IS SIMILAR**

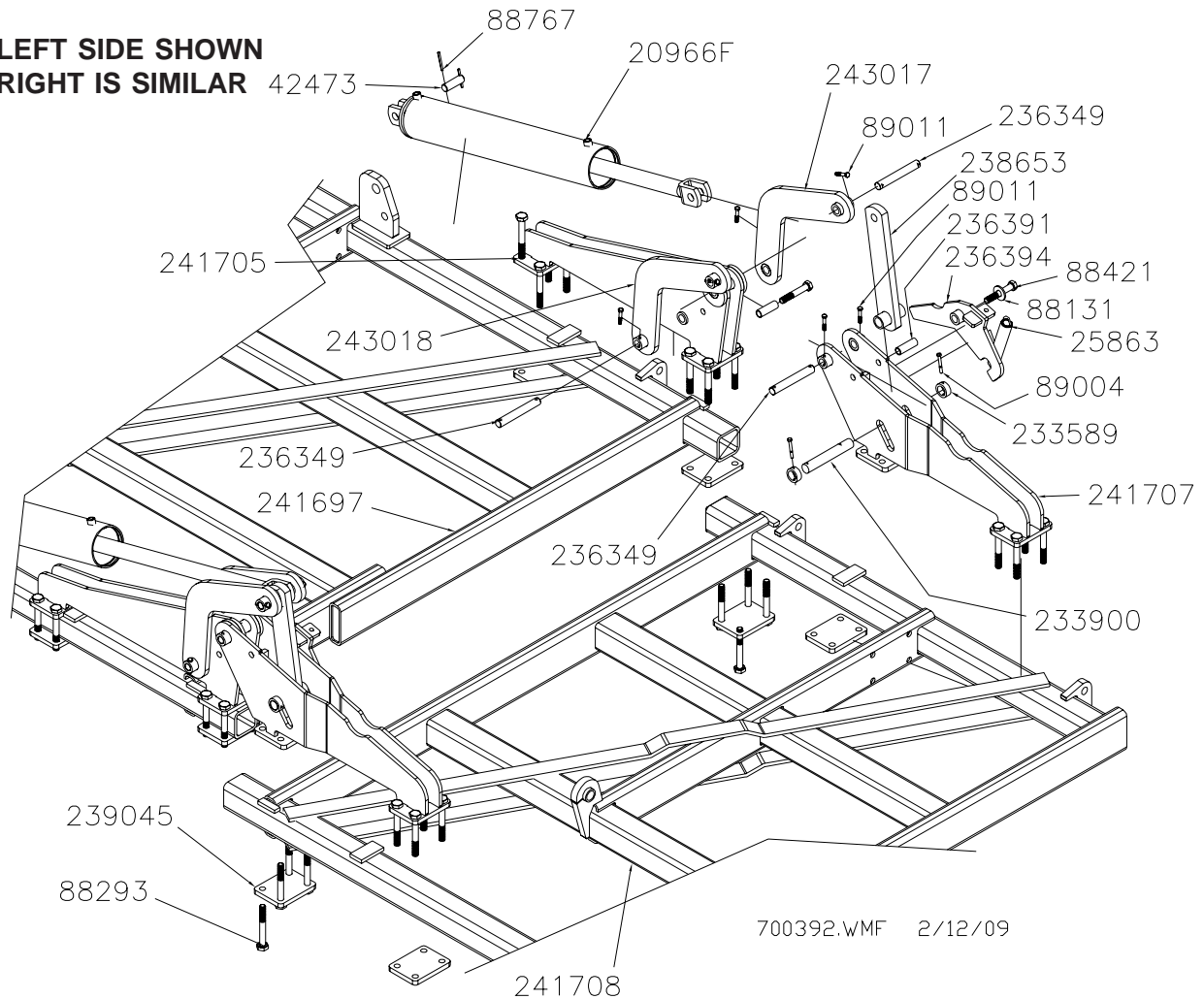

UNLESS SPECIFIED, ALL HARDWARE IS SECURED WITH MATCHING LOCK NUTS

PART NO.	DESCRIPTION	QTY	PART NO.	DESCRIPTION	QTY
20966F	HYD CYL 5X30 FGS #A519CY07	2	243017	OUTER FOLD LINK - FRONT	2
233589	PIN BUSHING (ZINC)	4	243018	OUTER FOLD LINK - REAR	2
233900	LOCK PIN	2	25863	SPRING	1
236349	HINGE PIN (ZINC)	6	42473	HEADLESS PIN (H) (2) 1X2-3/8	2
236391	PIVOT TUBE (ZINC)	4	88131	WSHR FLAT 3/4(13/16X2ACT) Z	2
236394	OUTER WING LATCH BRACKET	2	88196	WSHR FLAT 1(1-1/16X2-1/2ACT) Z	4
238653	OUTER FOLD LINK - LONG	2	88293	BLT HEX 3/4-10NCX6 5Z	32
239045	HINGE TIE PLATE - PAINTED	8	88421	BLT HEX 3/4-10NCX4-1/2 5Z	4
241697	LEFT INNER ATD WING - SHORT	1	88767	PIN ROLL 1/4DIA X2-1/2 Z	2
241705	INNER WING HINGE	2	89004	BLT HEX 5/16-18NCX2-1/2 5Z	4
241707	OUTER HINGE PIVOT	2	89011	BLT HEX 3/8-16NC X 2 5Z	12
241708	LEFT OUTER WING ATD SHORT	1			

LEFT OUTER WING ASSEMBLY - 60'

**HDW KIT
74285-5**

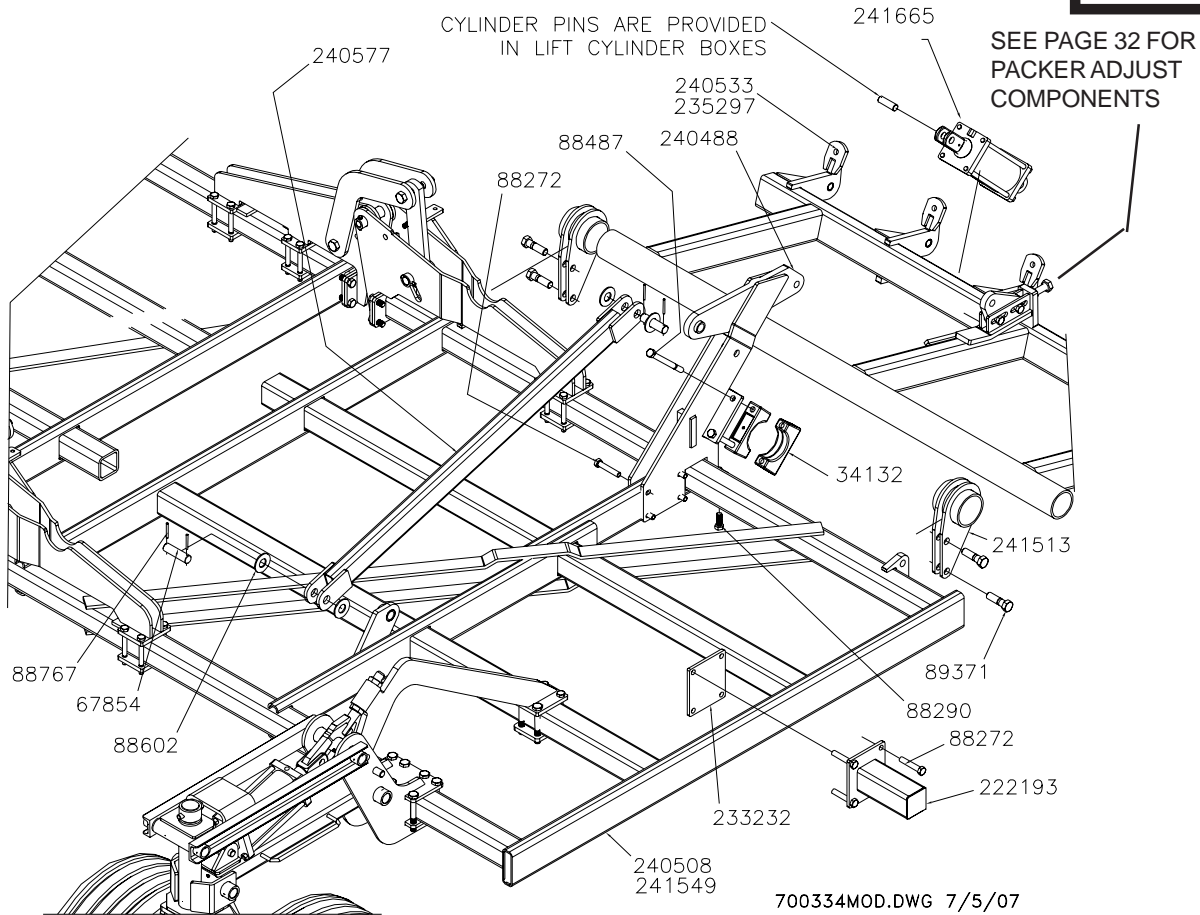

PART NO.	DESCRIPTION	QTY
222193	CP SHANK STUB	1
233232	STUB PLATE PAINTED	1
240488	PACKER LIFT BRACKET	1
240508	LEFT OUTER WING - ATD (UP TO SER #457600)	1
241549	LEFT OUTER WING - ATD (ABOVE SER #457601)	1
240533	LEFT OUTER PACKER MOUNT (UP TO SER #457600)	1
235297	LEFT OUTER PACKER MOUNT (ABOVE SER #457601)	1
240577	WING MAST TUBE	1
241513	CENTER PACKER HANGER	2
241665	3-1/2X8 CYLINDER WITH SPACER	1
34132	AXLE CLAMP ASSEMBLY (RED)	4
67854	HEADLESS PIN(2) 1-1/4X3-23/32	2
88272	BLT HEX 3/4-10NCX4 5Z	8
88290	BLT HEX 3/4-10NCX2 8YZ	2
88487	BLT HEX 3/4-10NCX8-1/2 5Z	4
88602	WSHR FLAT 1-1/4(1-3/8X3ACT) Z	4
88767	PIN ROLL 1/4DIAX2-1/2 Z	4
89371	BLT HEX 1-8NCX3-1/2 8YZ	4

**UNLESS SPECIFIED, ALL
HARDWARE IS SECURED
WITH MATCHING
LOCK NUTS**

**HDW KIT
74285-5**

LEFT OUTER WING ASSEMBLY - 50'

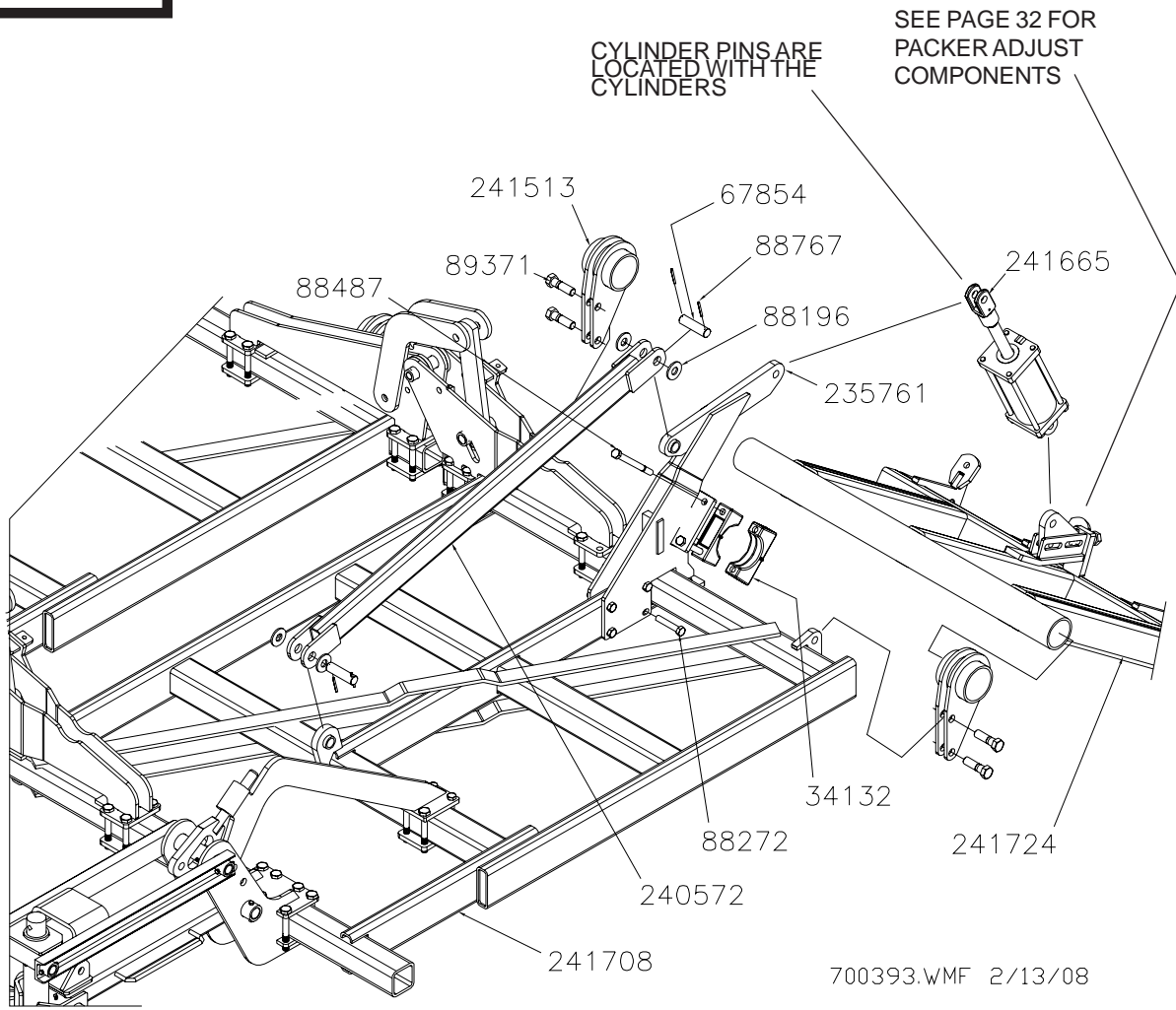

UNLESS SPECIFIED, ALL HARDWARE IS SECURED WITH MATCHING LOCK NUTS

NAME	DESCRIPTION	QTY	NAME	DESCRIPTION	QTY
241665	HYD CYL 3-1/2X8 WITH SPACER	1	67854	HEADLESS PIN(2) 1-1/4X3-23/32	2
235761	PACKER LIFT BRACKET	1	88196	WSHR FLAT 1(1-1/16X2-1/2ACT) Z	4
240572	LIFT MAST TUBE	1	88272	BLT HEX 3/4-10NCX4 5Z	4
241513	CENTER PACKER HANGER	2	88487	BLT HEX 3/4-10NCX8-1/2 5Z	4
241708	LEFT OUTER WING ATD SHORT	1	88767	PIN ROLL 1/4DIA X2-1/2 Z	4
241724	OUTER PACKER MOUNT-SHORT	1	89371	BLT HEX 1-8NCX3-1/2 8YZ	4
34132	AXLE CLAMP ASSEMBLY (RED)	4			

RIGHT INNER WING ASSEMBLY - 40' & 60'

**HDW KIT
74285-6**

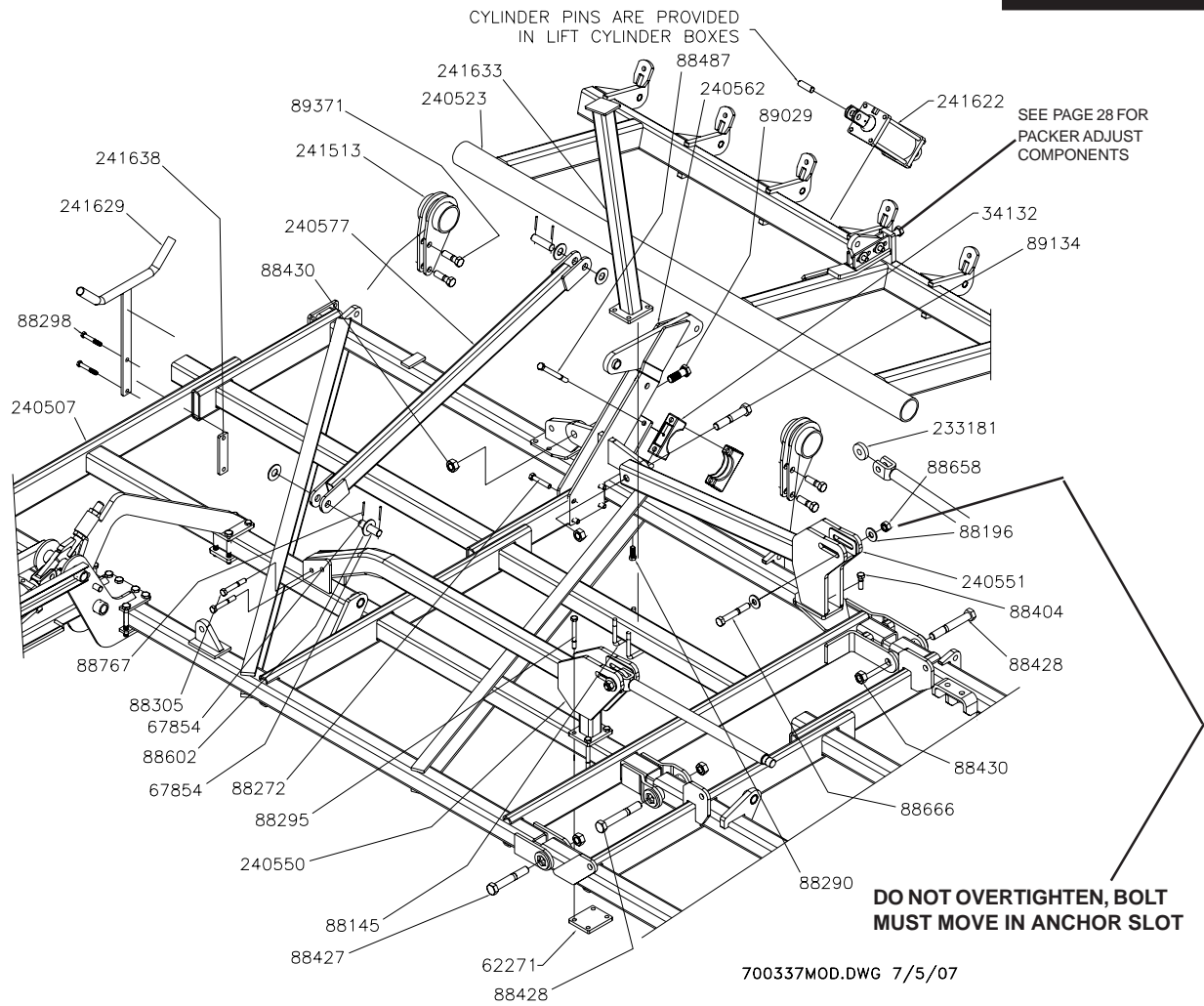

PART NO.	DESCRIPTION	QTY	PART NO.	DESCRIPTION	QTY
233181	LINK DONUT	2	88272	BLT HEX 3/4-10NCX4 5Z	4
240507	RIGHT INNER WING - ATD	1	88290	BLT HEX 3/4-10NCX2 8YZ	2
240523	RIGHT INNER WING PACKER MOUNT	1	88295	BLT HEX 5/8-11NCX6 5Z	4
240550	FRONT WING ANCHOR	1	88298	BLT HEX 5/8-11NCX4 5Z (OPT)	2
240551	REAR LIFT ASSEMBLY	1	88305	BLT HEX 3/4-10NCX5 5Z	2
240562	WING PACKER TOWER	1	88404	BLT HEX 3/4-10NCX2-1/2 5Z	3
240577	WING MAST TUBE	1	88427	BLT HEX 1-1/4-7NCX8 5Z	1
241513	CENTER PACKER HANGER	2	88428	BLT HEX 1-1/4-7NCX9 5Z	2
241622	HYD CYL 4-1/2X8 SEQ	1	88430	NUT 2POS LK 1-1/4-7NC 5Z	5
241629	OUTER WING HOSE SUPPORT (OPT)	1	88487	BLT HEX 3/4-10NCX8-1/2 5Z	4
241633	OUTER WING REST - ATD	1	88602	WSHR FLAT 1-1/4(1-3/8X3ACT) Z	4
241638	FLAT (OPT)	1	88658	NUT TOP LK 1-8NC 5Z	2
34132	AXLE CLAMP ASSEMBLY (RED)	4	88666	BLT HEX 1-8NCX6-1/2 5Z	2
62271	FRAME PLATE (RED)	1	88767	PIN ROLL 1/4DIA X2-1/2 Z	4
67854	HEADLESS PIN(2) 1-1/4X3-23/32	2	89029	BLT HEX 1-1/4-7NC X 4 5Z	1
88145	BLT-U 5/8-11NCX4X5-1/4 Z	2	89134	BLT HEX 1-1/4-7NCX7 5Z	1
88196	WSHR FLAT 1(1-1/16X2-1/2ACT) Z	4	89371	BLT HEX 1-8NCX3-1/2 8YZ	4

**HDW KIT
74285-6**

RIGHT INNER WING ASSEMBLY - 50'

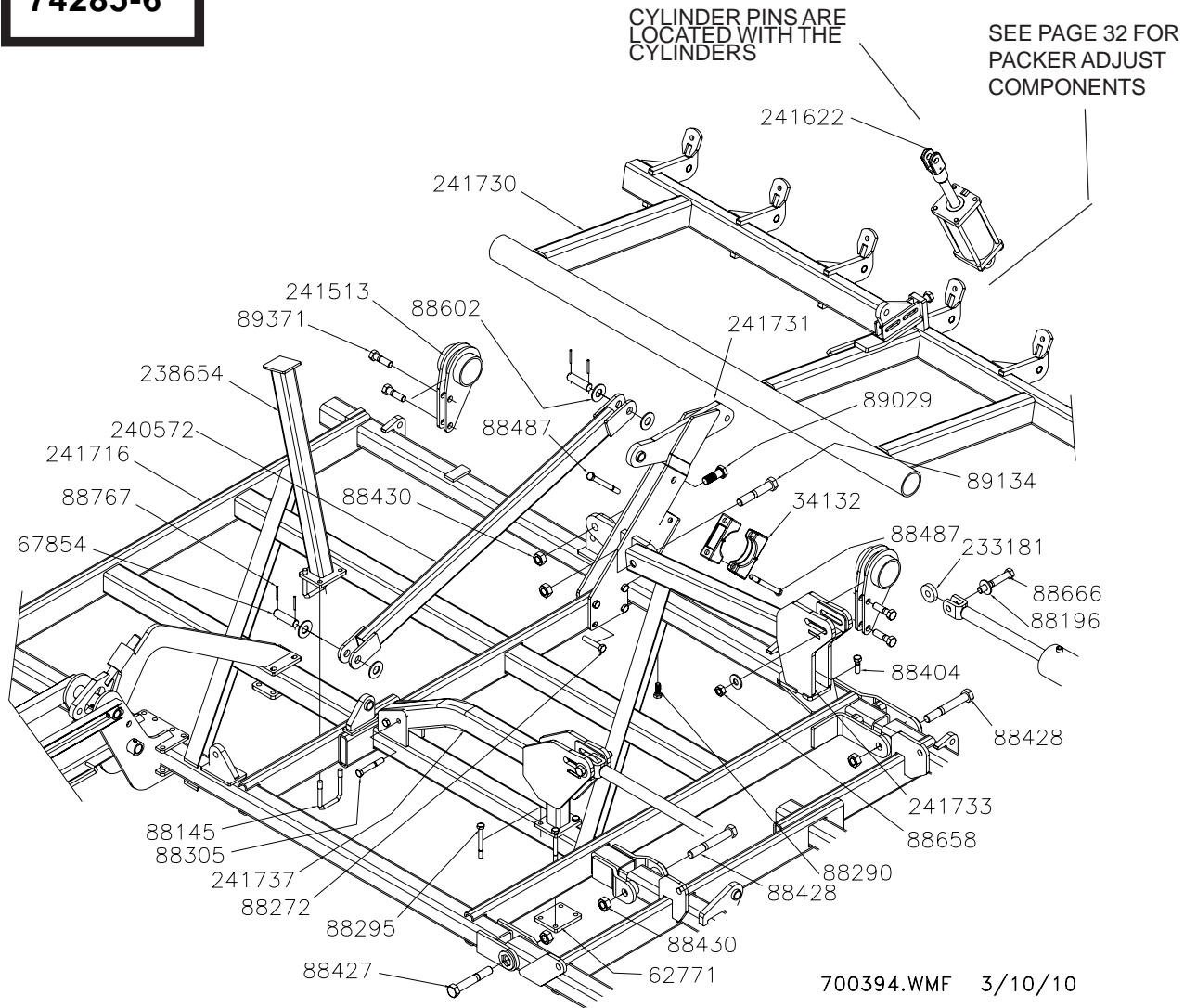

PART NO.	DESCRIPTION	QTY	PART NO.	DESCRIPTION	QTY
62271	FRAME PLATE	1	88290	BLT HEX 3/4-10NCX2 8YZ	2
233181	LINK DONUT (ZINC)	2	88295	BLT HEX 5/8-11NCX6 5Z	4
238654	OUTER SHORT WING REST - ATD	1	88305	BLT HEX 3/4-10NCX5 5Z	2
240572	LIFT MAST TUBE	1	88404	BLT HEX 3/4-10NCX2-1/2 5Z	3
241513	CENTER PACKER HANGER	2	88427	BLT HEX 1-1/4-7NCX8 5Z	1
241622	HYD CYL 4-1/2X8 SEQ	1	88428	BLT HEX 1-1/4-7NCX9 5Z	2
241716	RIGHT INNER ATD WING - SHORT	1	88430	NUT 2POSLK 1-1/4-7NC 5Z	5
241730	RIGHT INNER WING PACKER MOUNT	1	88487	BLT HEX 3/4-10NCX8-1/2 5Z	4
241731	SHORT INNER WING PACKER TOWER	1	88602	WSHR FLAT 1-1/4(1-3/8X3ACT) Z	4
241733	REAR LIFT ASSEMBLY - SHORT	1	88658	NUT TOP LK 1-8NC 5Z	2
241737	FRONT WING ANCHOR	1	88666	BLT HEX 1-8NCX6-1/2 5Z	2
34132	AXLE CLAMP ASSEMBLY (RED)	4	88767	PIN ROLL 1/4DIA X2-1/2 Z	4
67854	HEADLESS PIN(2) 1-1/4X3-23/32	2	89029	BLT HEX 1-1/4-7NC X 4 5Z	1
88145	BLT-U 5/8-11NCX4X5-1/4 Z	2	89134	BLT HEX 1-1/4-7NCX7 5Z	1
88196	WSHR FLAT 1(1-1/16X2-1/2ACT) Z	4	89371	BLT HEX 1-8NCX3-1/2 8YZ	4
88272	BLT HEX 3/4-10NCX4 5Z	4			

RIGHT OUTER WING ASSEMBLY - 60'

**HDW KIT
74285-8**

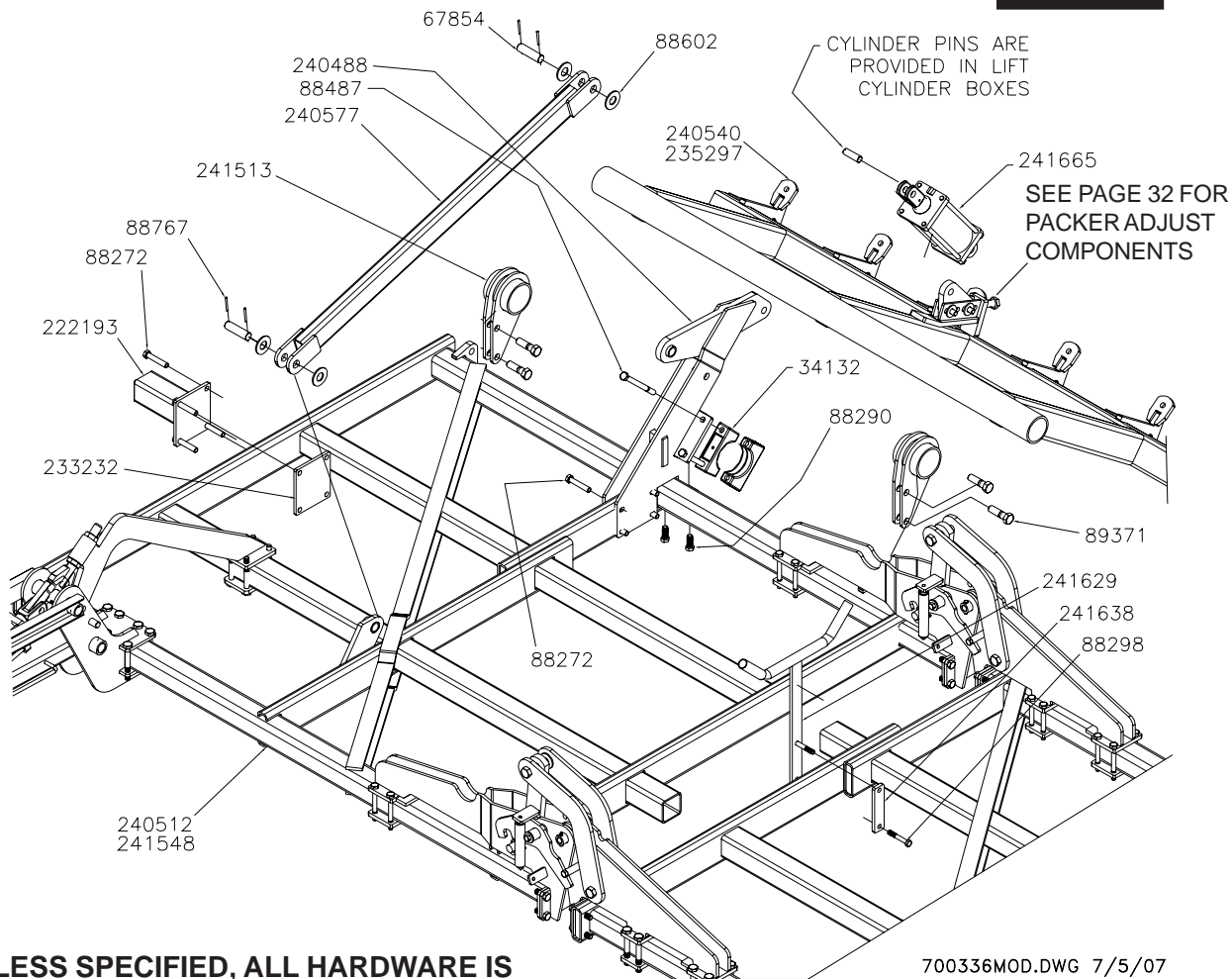

UNLESS SPECIFIED, ALL HARDWARE IS SECURED WITH MATCHING LOCK NUTS

700336MOD.DWG 7/5/07

PART NO.	DESCRIPTION	QTY	PART NO.	DESCRIPTION	QTY
222193	CP SHANK STUB	1	241665	3-1/2X8 CYLINDER WITH SPACER	1
233232	STUB PLATE PAINTED	1	34132	AXLE CLAMP ASSEMBLY (RED)	4
240488	PACKER LIFT BRACKET	1	67854	HEADLESS PIN(2) 1-1/4X3-23/32	2
240512	RIGHT OUTER WING - ATD (UP TO SER #457600)	1	88272	BLT HEX 3/4-10NCX4 5Z	8
241548	RIGHT OUTER WING - ATD (ABOVE SER #457601)	1	88290	BLT HEX 3/4-10NCX2 8YZ	2
240540	RIGHT OUTER PACKER MNT (UP TO SER #457600)	1	88298	BLT HEX 5/8-11NCX4 5Z	2
235297	RIGHT OUTER PACKER MNT (ABOVE SER #457601)	1	88487	BLT HEX 3/4-10NCX8-1/2 5Z	4
240577	WING MAST TUBE	1	88602	WSHR FLAT 1-1/4(1-3/8X3ACT) Z	4
241513	CENTER PACKER HANGER	2	88767	PIN ROLL 1/4DIA X2-1/2 Z	4
241629	OUTER WING HOSE SUPPORT	1	89371	BLT HEX 1-8NCX3-1/2 8YZ	4
241638	FLAT	1			

RIGHT OUTER WING ASSEMBLY - 50'

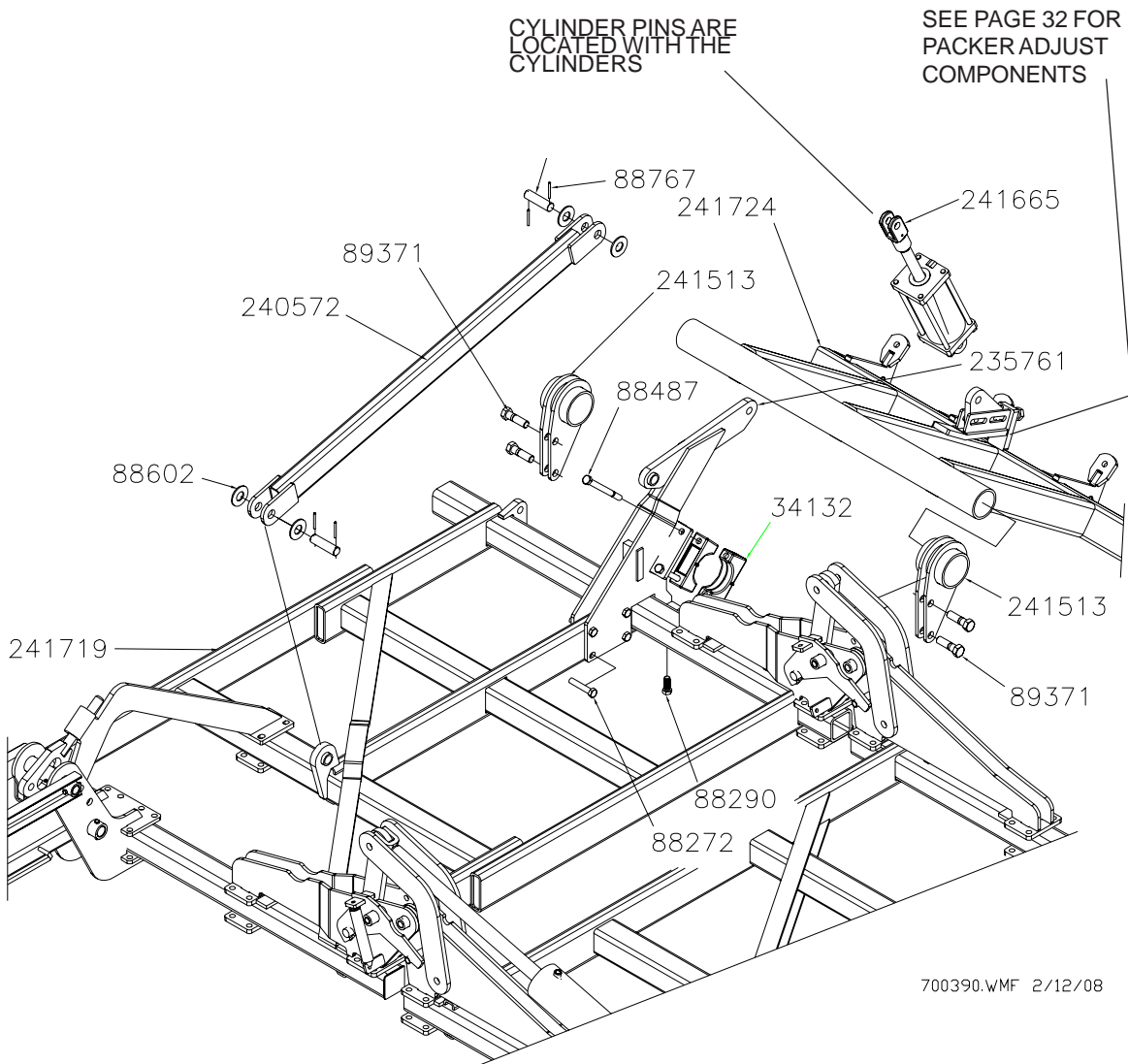

700390.WMF 2/12/08

**UNLESS SPECIFIED, ALL HARDWARE IS
SECURED WITH MATCHING LOCK NUTS**

PART NO.	DESCRIPTION	QTY	PART NO.	DESCRIPTION	QTY
241724	OUTER PACKER MOUNT-SHORT	1	88767	PIN ROLL 1/4DIAX2-1/2 Z	4
241719	RIGHT OUTER WING ATD SHORT	1	88602	WSHR FLAT 1-1/4(1-3/8X3ACT) Z	4
241665	HYD CYL 3-1/2X8 WITH SPACER	1	88487	BLT HEX 3/4-10NCX8-1/2 5Z	4
241513	CENTER PACKER HANGER	2	88290	BLT HEX 3/4-10NCX2 8YZ	2
240572	LIFT MAST TUBE	2	88272	BLT HEX 3/4-10NCX4 5Z	4
235761	PACKER LIFT BRACKET	1	67854	HEADLESS PIN(2) 1-1/4X3-23/32	2
89371	BLT HEX 1-8NCX3-1/2 8YZ	4	34132	AXLE CLAMP ASSEMBLY (RED)	4

WING LIFT WHEEL ASSEMBLY

**HDW KIT
74285-7**

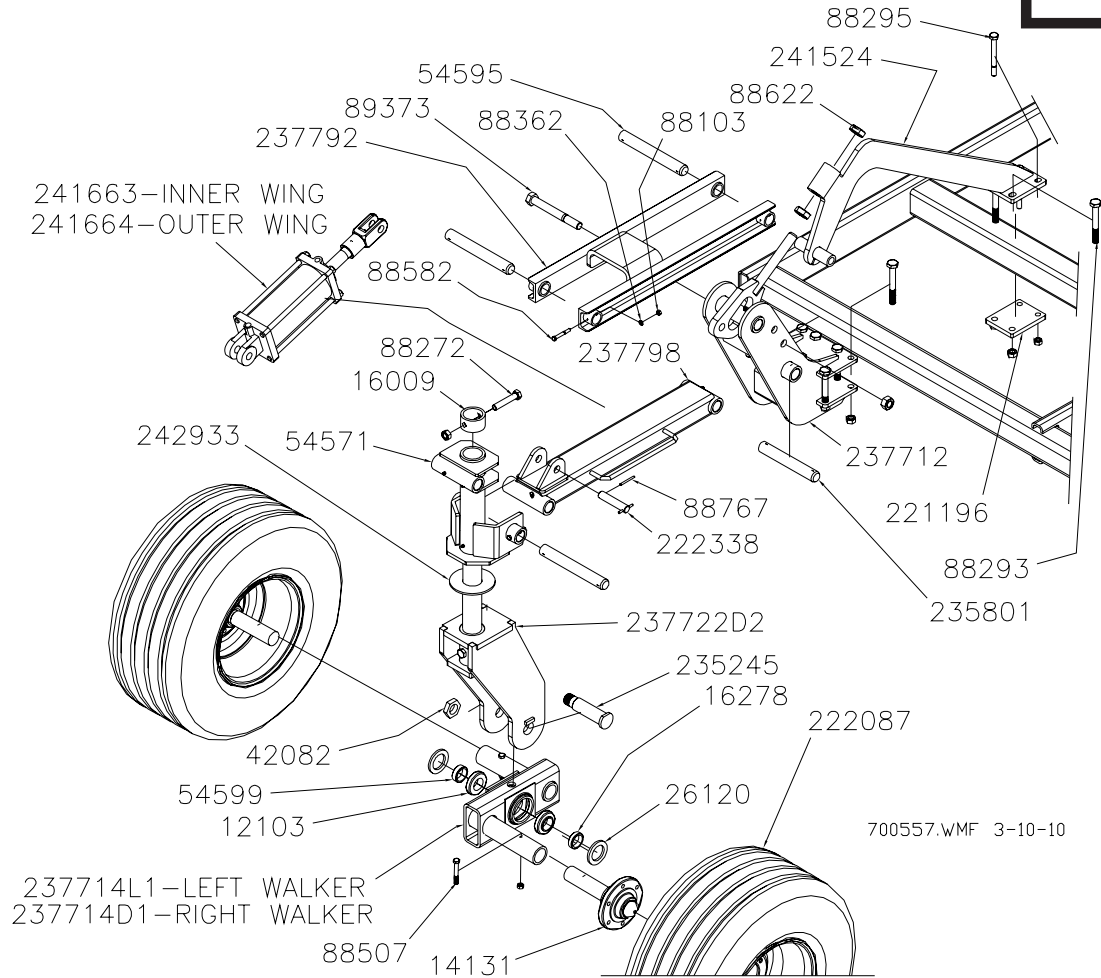

PART NO.	DESCRIPTION	QTY	PART NO.	DESCRIPTION	QTY
12103	BEARING CONE 1-3/4ID (25580)	2	241644	HYD CYL 3-3/4X8 WITH SPACER	1
14131	2IN HUB & SPINDLE (LG7830015)	2	242933	PIVOT WEAR PLATE	1
16009	COLLAR	1	26120	SEAL	2
16278	BEARING BUSHING	1	42082	1-1/2NF HYDRA JAM LOCK NUT	1
221196	MOUNT PLATE - PAINTED GRAY	1	54571	GAUGE WHEEL PIVOT	1
222087	WHL ASSY 31X13.5 6B 10" 12P GRAY	2	54595	HEADLESS PIN(2) 1-1/2X9-19/32	3
222338	HEADLESS PIN(2) 1X4-1/8	1	54599	WALKER BEARING BUSHING	1
235245	TANDEM PIN	1	88103	NUT HEX 3/8-16NC 5Z	8
235801	PIVOT PIN (1-1/2 X 10)	1	88272	BLT HEX 3/4-10NCX4 5Z	1
237712	FRONT MAST MOUNT - ATD	1	88293	BLT HEX 3/4-10NCX6 5Z	9
237714D1	LEFT OUTER WALKER - ATD	1	88295	BLT HEX 5/8-11NCX6 5Z	2
237714L1	RIGHT OUTER WALKER - ATD	1	88362	WSHR HLK 3/8ID Z	8
237722D2	WING FRONT AXLE PIVOT - ATD	1	88507	BLT HEX 1/2-13NCX3-1/2 5Z	2
237792	OUTER LINK ARM	1	88582	BLT HEX 3/8-16NCX2-3/4 5Z	8
237798	LOWER OUTER ARM	1	88622	NUT JAM 1-1/4-7NC 5Z	4
241524	FRONT MAST SUPPORT	1	88767	PIN ROLL 1/4DIA X2-1/2 Z	2
241663	HYD CYL 4X8 WITH SPACER	1	89373	BLT HEX 1-8NC X 8-1/2 8YZ	1

**THIS PAGE INTENTIONALLY
LEFT BLANK**

MAIN FRAME PACKER/LIFT ASSEMBLY

**UNLESS SPECIFIED, ALL HARDWARE IS
SECURED WITH MATCHING LOCK NUTS**

PART NO.	DESCRIPTION	QTY	PART NO.	DESCRIPTION	QTY
12103	BEARING CONE 1-3/4ID (25580)	4	241623	HYD CYL 4-3/4X8 SEQ	2
16154	2-1/2IN HUB&SPINDLE ASSY(LG8210011)	4	26120	SEAL	4
16278	BEARING BUSHING	2	34132	AXLE CLAMP ASSEMBLY (RED)	8
221347D1	RIGHT 3X11 HD WALKING TANDEM	1	42082	1-1/2NF HYDRA JAM LOCK NUT	2
221347D1R	LEFT 3X11 HD WALKING TANDEM	1	22022	HEADLESS PIN(2) 1-1/4X2-7/16	2
222213F1	HYD CYL 4X16 FGS #A519CY26	2	54599	WALKER BEARING BUSHING	2
222259	WHL ASSY 31X13.5 8B 10" 12P	4	67854	HEADLESS PIN(2) 1-1/4X3-23/32	8
234811	1/2X4 BENT PIN W/HAIRPIN	2	68399	HEADLESS PIN(2) 1-1/4X7-1/8	2
234836	REAR BRACE TUBE	2	88125	NUT HEX 1-8NC 5Z	2
235245	TANDEM PIN	2	88131	WSHR FLAT 3/4(13/16X2ACT) Z	8
237756D1	REAR LIFT AXLE - LEFT	1	88181	BLT HEX 1-8NCX7 5Z	8
237756D1R	REAR LIFT AXLE - RIGHT	1	88272	BLT HEX 3/4-10NCX4 5Z	8
237961D1	LIFT AXLE PIVOT	4	88290	BLT HEX 3/4-10NCX2 8YZ	4
240438	MAIN FRAME - ATD	1	88291	BLT HEX 3/4-10NCX3 5Z	4
240479	CENTER PACKER MOUNT	1	88381	BLT HEX 5/8-11NCX4-1/2 5Z	4
240484	PACKER LIFT ANCHOR	2	88398	BLT HEX 1-8NCX4 5Z	4
240488	PACKER LIFT BRACKET	2	88487	BLT HEX 3/4-10NCX8-1/2 5Z	8
240554	REAR LIFT MAST	2	88495	BLT HEX 7/8-9NCX2-1/2 5Z	8
240567	MAIN MAST TUBE	2	88602	WSHR FLAT 1-1/4(1-3/8X3ACT) Z	20
240572	LIFT MAST TUBE	2	88767	PIN ROLL 1/4DIA X2-1/2 Z	24
241513	CENTER PACKER HANGER	2	89371	BLT HEX 1-8NCX3-1/2 8YZ	4
241572	ADJUSTMENT SCREW	2	89389	BLT HEX 3/4-10NCX2-1/2 8YZ	8
241584	REAR CYLINDER CHANNEL LOCK	2			

REAR PACKER ASSEMBLY

**HDW KIT
74285-10**

SEE PAGE 37 FOR ADDITIONAL CRITICAL ASSEMBLY INFORMATION

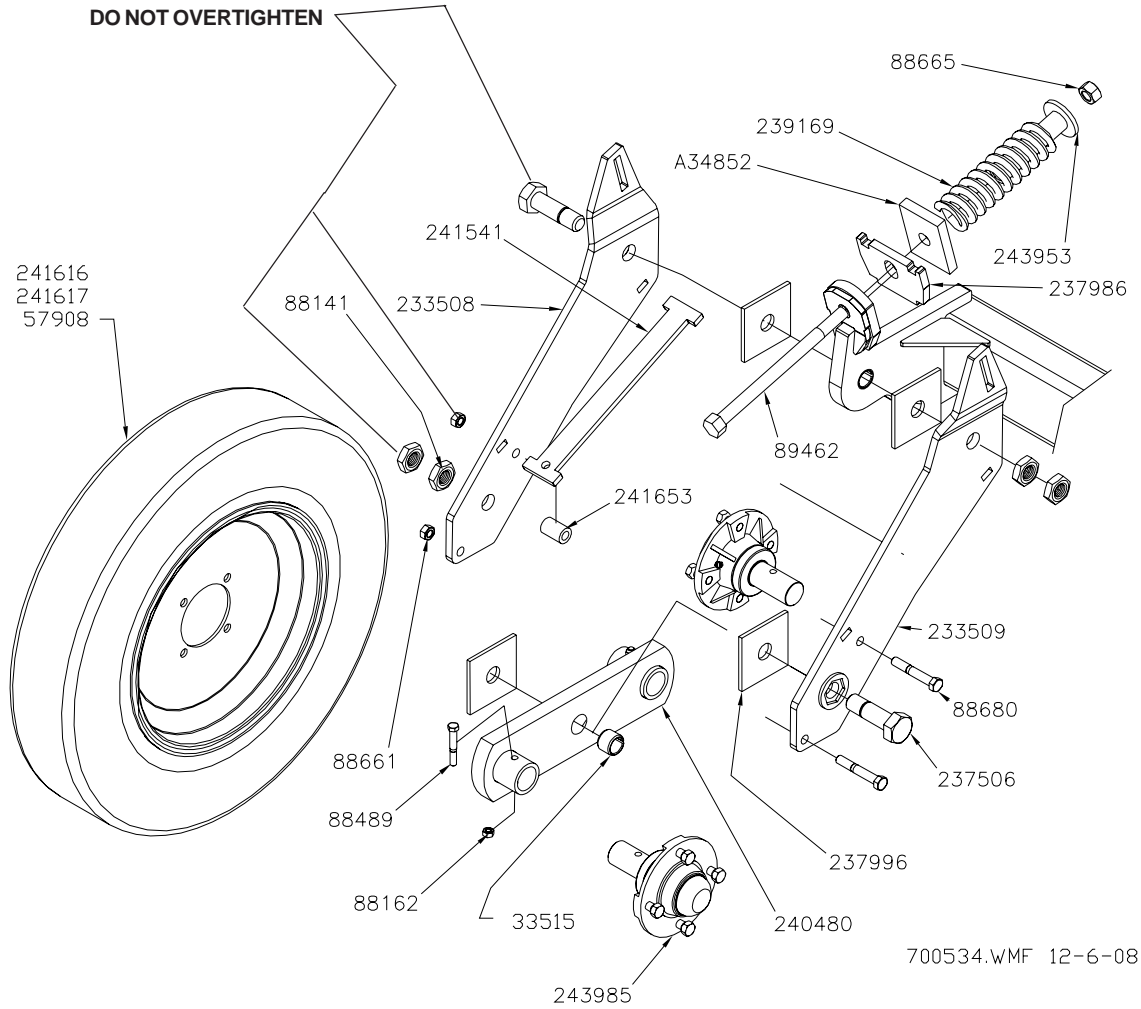

PART NO.	DESCRIPTION	QTY	PART NO.	DESCRIPTION	QTY
233508	LEFT PACKER ARM	1	243985	2009 PACKER HUB & SPINDLE ASSY	2
233509	RIGHT PACKER ARM	1	88141	NUT JAM 1-8NC 5Z	4
237506	1NCX3-1/2 SPECIAL HEX HEAD BOLT	2	88162	NUT 2POSLK 3/8-16NC 5P	2
237986	SPRING PLATE--PAINTED BLACK	1	88489	BLT HEX 3/8-16NCX2-1/2 8YZ	2
237996	WALKER PIVOT WASHER	4	88661	NUT TOP LK 1/2-13NC 5Z	2
239169	SPRING - PAINTED BLACK	1	88665	NUT TOP LK 3/4-10NC 5Z	1
240480	PACKER WALKER - 10 IN	1	88680	BLT HEX 1/2-13NCX3-1/4 5Z	1
241541	INNER PACKER PLATE (BLACK)	1	89462	BLT-HEX 3/4X10NCX10-1/2 8Z	1
241616	PACKER RIM 4.5X15 4 BOLT	1	A34852	PLATE-TDD SPRING RETAINER	1
241617	PACKER TIRE 26/6.50X15	1	57908	VALVE ASSEMBLY (STEEL)	1
241653	PACKER SPACER (ZINC)	1	33515	SPRING TENSION BUSHING (1")	1
243953	SPRING CENTERING WASHER/TUBE	2			

PACKER ASSEMBLY/SETTING INFORMATION

ONCE EACH PACKER ASSEMBLY HAS BEEN COMPLETED WITHOUT MOUNTING THE SPRING, IT IS CRITICAL TO PROPERLY SET THE TIGHTNESS OF THE PACKER ADJUST POINTS INDICATED. **THE SPRING LOADED PACKER ASSEMBLIES WILL NOT FUNCTION PROPERLY IF THE NOTED POINTS ARE OVER TIGHTENED. BOTH THE SPRING PIVOT ARMS AND PACKER WALKERS MUST ROTATE FREELY.**

TIGHTEN THE UPPER AND LOWER MAIN PIVOT BOLTS BY ADJUSTING THE INNER JAM NUT. CHECK TO ENSURE THE ARMS AND WALKER ARE FREE TO PIVOT. HOLD THE INNER JAM NUT WITH A WRENCH AND LOCK WITH THE OUTER JAM NUT. **DO NOT USE AN AIR WRENCH TO TIGHTEN ANY OF THE PACKER ADJUST POINTS.** ADJUST THE TWO (2) CLAMP BOLTS, CHECKING TO ENSURE THAT THE WALKER IS FREE TO PIVOT.

IF THE PACKER ADJUST POINTS ARE TIGHT THE SPRING WILL NOT RETURN THE SPRING ARMS TO THE CORRECT POINT AND THE DEPTH CONTROL AND PACKING OF THE REAR OF THE UNIT WILL BE INCONSISTENT. WITH THE PACKER ARMS AND WALKERS ABLE TO ROTATE AND THE SPRINGS SET AS NOTED BELOW THE PACKERS SHOULD CARRY THE REAR OF THE UNIT AT A CONSISTENT DEPTH AND ALLOW THE SPRING LOADED ARMS TO PIVOT WHEN OBSTACLES ARE ENCOUNTERED.

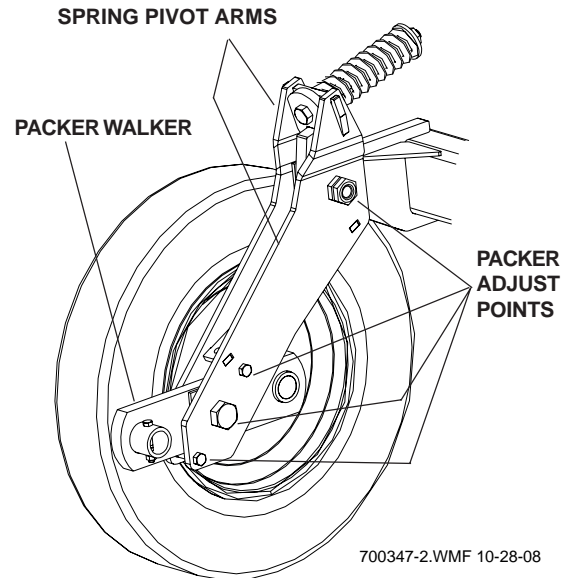

PACKER SPRING SETTINGS

TO MAINTAIN PROPER REAR MACHINE DEPTH THE SPRING ON EACH PACKER ASSEMBLY MUST BE ADJUSTED TO BALANCE THE WEIGHT OF THE MACHINE AND ALLOW PROPER RELIEF OF THE PACKER WHEELS WHEN ENCOUNTERING UNEVEN TERRAIN. ONCE THE PACKER PIVOTS HAVE BEEN PROPERLY ADJUSTED AS NOTED ABOVE THE SPRING CAN BE ADDED AND THE SPRING NUTS ADJUSTED. THIS SHOULD BE DONE WHEN THE UNIT IS COMPLETELY ASSEMBLED AND LEVELLED ON A FLAT SURFACE PRIOR TO GOING TO THE FIELD. LOWER THE UNIT SO THE SHANKS OR INJECTORS JUST CLEAR THE GROUND.

ALL SPRINGS SHOULD BE SET TO MAINTAIN CONTACT BETWEEN THE SPRING PLATE AND THE FRAME STOP ON EACH PACKER PIVOT. THIS SETTING IS DEPENDENT ON THE LOAD THAT IS SEEN BY EACH PACKER. SINCE THERE IS MORE WEIGHT ON MOST OF THE MAIN FRAME PACKERS THE SPRING SETTING (SS) WILL BE GREATER THAN REQUIRED ON THE OUTER WINGS. SET THE SPRING DISTANCE (SS) ON ALL SPRINGS TO MAINTAIN THE SPRING PLATE TO FRAME STOP CONTACT WITH THE WEIGHT OF THE UNIT. WHEN PROPERLY SET THE PACKERS SHOULD NOT MOVE EXCESSIVELY UNLESS THE PACKER WHEELS ENCOUNTER UNEVEN GROUND OR AN OBSTRUCTION.

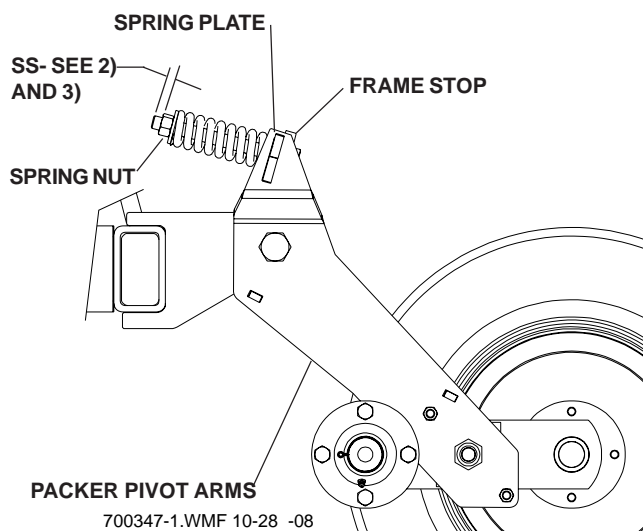

1) WITH THE MAIN FRAME LEVEL TIGHTEN THE SPRING BOLT TO A (SS) DISTANCE OF APPROXIMATELY 3/8"-1/2" ON ALL THE MAIN FRAME PACKERS.

2) TIGHTEN THE PACKER SPRINGS ON THE INNER PORTION OF THE INNER WINGS TO A (SS) DISTANCE OF 3/8"-1/2" WITH THE REMAINING WING PACKER SPRINGS TO A LESSER DISTANCE.

3) DEPENDING ON THE WEIGHT AND SIZE OF THE UNIT TIGHTEN THE REMAINING PACKER SPRINGS ON THE OUTER WINGS TO A 1/4" TO 3/8" DIMENSION.

4) CHECK TO ENSURE THAT THE SPRING PLATE TO FRAME STOP CONTACT IS MAINTAINED TO ENSURE THAT ALL PACKERS ARE SET TO THE SAME DEPTH.

5) PROCEED TO COMPLETING THE FIELD SETTINGS AND CHECK TO SEE THAT THE STOP CONTACT IS MAINTAINED AS THE UNIT MOVES THROUGH THE FIELD. IF THE PACKER PIVOT ARMS ARE MOVING EXCESSIVELY DUE TO NORMAL LOADING, NOT OBSTRUCTIONS, TIGHTEN THE SPRING NUTS. TIGHTEN SPRINGS ONLY TO THE POINT OF MAINTAINING SPRING PLATE TO FRAME STOP CONTACT WHILE OPERATING. EXCESS SPRING PRESSURE WILL RESTRICT RELIEF WHEN ENCOUNTERING OBSTRUCTIONS.

REAR HITCH ASSEMBLY

HDW KIT 74285-1

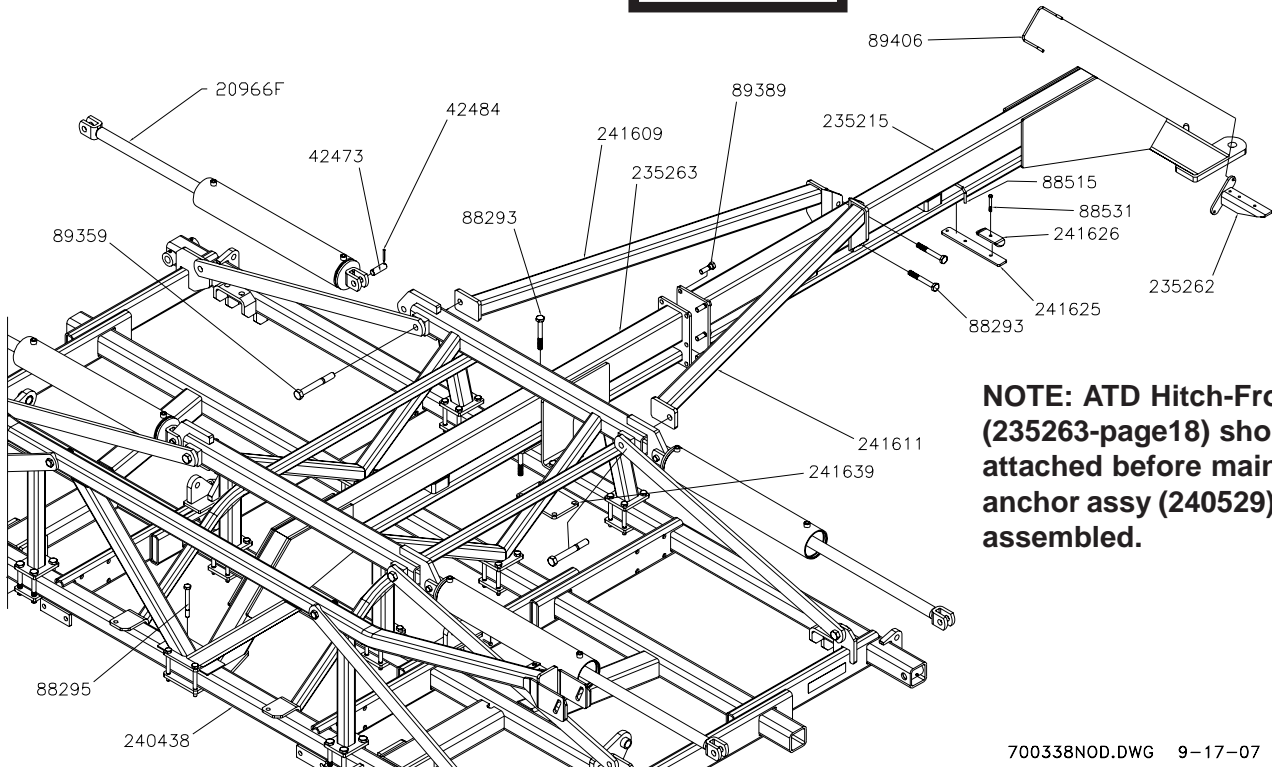

NOTE: ATD Hitch-Front (235263-page18) should be attached before main frame anchor assy (240529) is assembled.

700338NOD.DWG 9-17-07

HDW KIT 74285-1

PART NO.	DESCRIPTION	QTY
20966F	HYD CYL 5X30 FGS #A519CY07	4
241639	REAR HITCH PLATE	1
241626	HOSE CLAMP	7
241625	HOSE BRACKET	6
241611	REAR HITCH BRACE - LEFT	1
241609	REAR HITCH BRACE -RIGHT	1
240438	MAIN FRAME - ATD	1
235263	ATD HITCH - FRONT	1
235262	HOSE BRACKET	1
235215	ATD HITCH - REAR	1
89406	BLT-U 3/8-NCX6 X 5	1
89389	BLT HEX 3/4-10NCX2-1/2 8YZ	6
89359	BLT HEX 1X8NC X 8 8YZ	2
88531	BLT HEX 3/8-16NCX3 5Z	7
88515	BLT-U 3/8-16NCX4X2-3/4 Z	6
88295	BLT HEX 5/8-11NCX6 5Z	4
88293	BLT HEX 3/4-10NCX6 5Z	6
42484	1/4 X 2-1/4 ROLL PIN	8
42473	HEADLESS PIN (H) (2) 1X2-3/8	4

LIFT SENSOR MOUNT ASSEMBLY

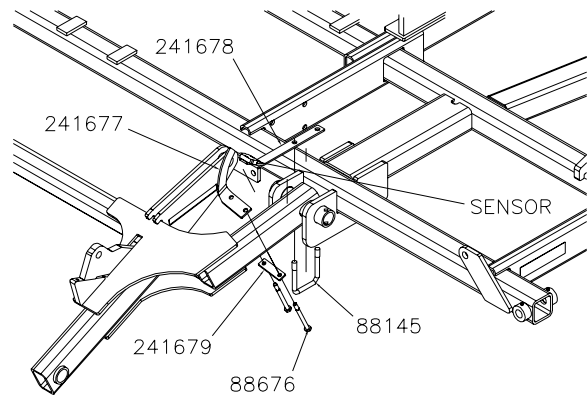

700350MOD.DWG 3-2-07

PART NO.	DESCRIPTION	QTY
241677	SENSOR MOUNT	1
241678	SENSOR PLATE	1
241679	TIE STRAP	1
88145	BLT-U 5/8-11NCX4X5-1/4 Z	1
88676	BLT HEX 1/2-13NCX6-1/2 5Z	2
SENSOR	SENSOR	1

CHISEL PLOW SHANK ASSEMBLY

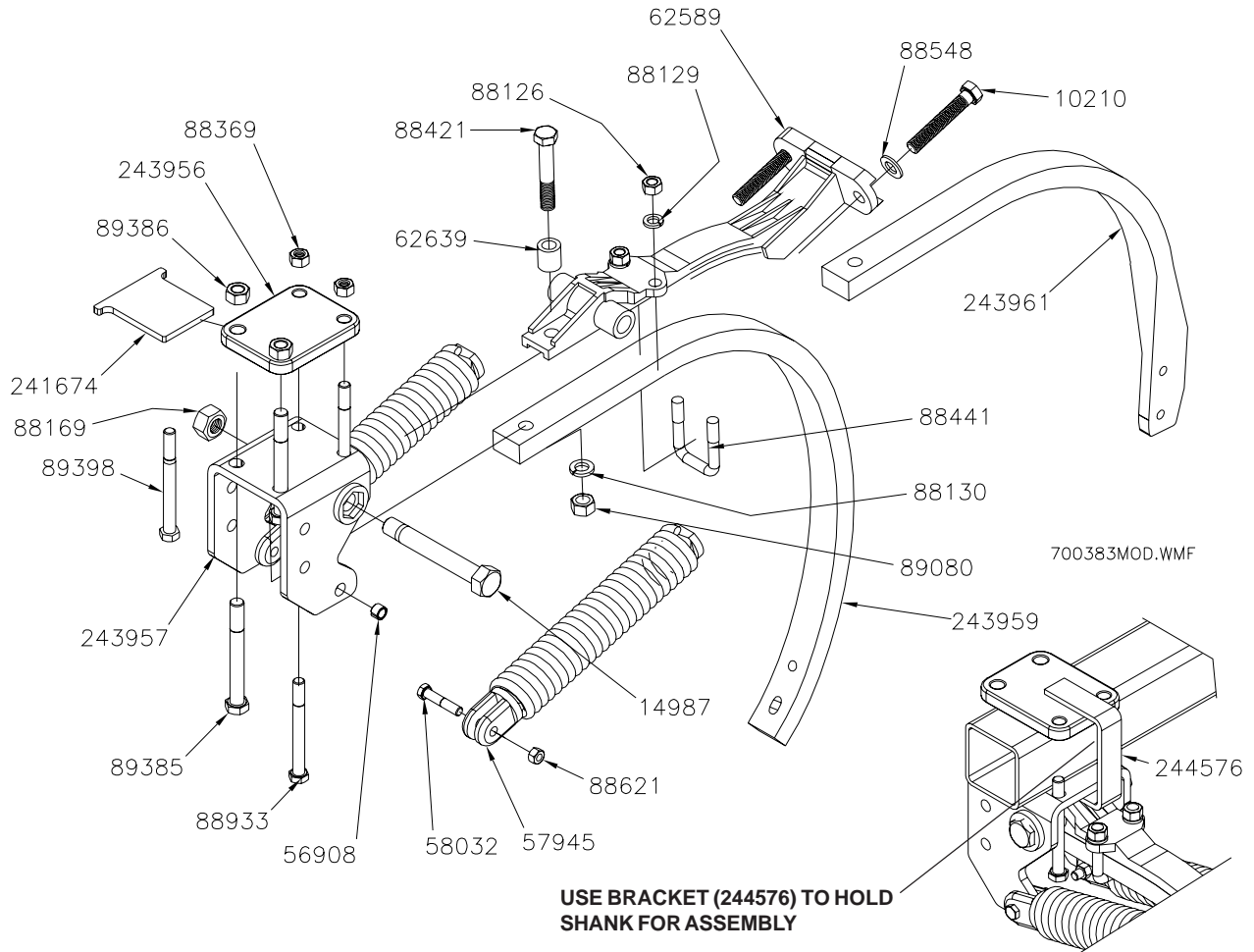

89398 BOLT USED WITH 241764 SHIM
AND 241675 SHIM KIT

243954-EDGE-ON SHANK ASSY (BLACK)
243955-CHISEL SHANK ASSY (BLACK)

PART NO.	DESCRIPTION	QTY	PART NO.	DESCRIPTION	QTY
10210	ADJUSTMENT BOLT	2	88441	BLT-U 5/8-11NCX2X3-1/4 Z	1
14987	PIVOT BOLT (CP SHANK)	1	88548	WSHR FLAT 3/4SAE(13/16X1-1/2) Z	2
48836	CAST SPRING YOKE	1	88621	NUT NLK 1/2-13NC 5Z	2
56908	1/2" SPRING TENSION BUSHING	2	88933	BLT HEX 5/8NCX6 8YZ	2
56910	13-15/16 EXTENSION SPRING	1	89080	NUT HEX 3/4-10NC 8YZ	1
57945	16.12 SPRING ASSEMBLY	2	89385	BLT HEX 3/4-16NF6-1/2 8YZ	2
57963	CAST SPRING PLUG	1	89386	NUT NYL 3/4-16NF 8YZ	2
58032	HDN 1/2 X 2-1/2 BOLT Z	2	89398	BLT HEX 5/8-11NCX6-1/2 8YZ	24
62589	DUCTILE PIVOT ARM	1	241674	3/8 IN SHANK SHIM	12
62639	STOP COLLAR	1	243954	EDGE-ON CP SHANK ASSY (BLACK)	1
88126	NUT HEX 5/8-11NC 5Z	2	243955	CP SHANK ASSY 32IN (BLACK)	1
88129	WSHR HLK 5/8ID(11/16ACT) Z	2	243956	CAST TOP PLATE (BLACK)	1
88130	WSHR HLK 3/4ID(13/16ACT) Z	1	243957	SHANK HOLDER FRAME BRKT (BLACK)	1
88169	NUT 2POSLK 1-14NF 5Z	1	243959	54 DEG 32IN CP SHK (BLACK)	1
88369	NUT 2POSLK 5/8-11NC 5Z	2	243961	SHANK EDGE ON (BLACK)	1
88421	BLT HEX 3/4-10NCX4-1/2 5Z	1	244576	SHANK MOUNT TOOL	2

DISC LEVELER - OPTIONAL

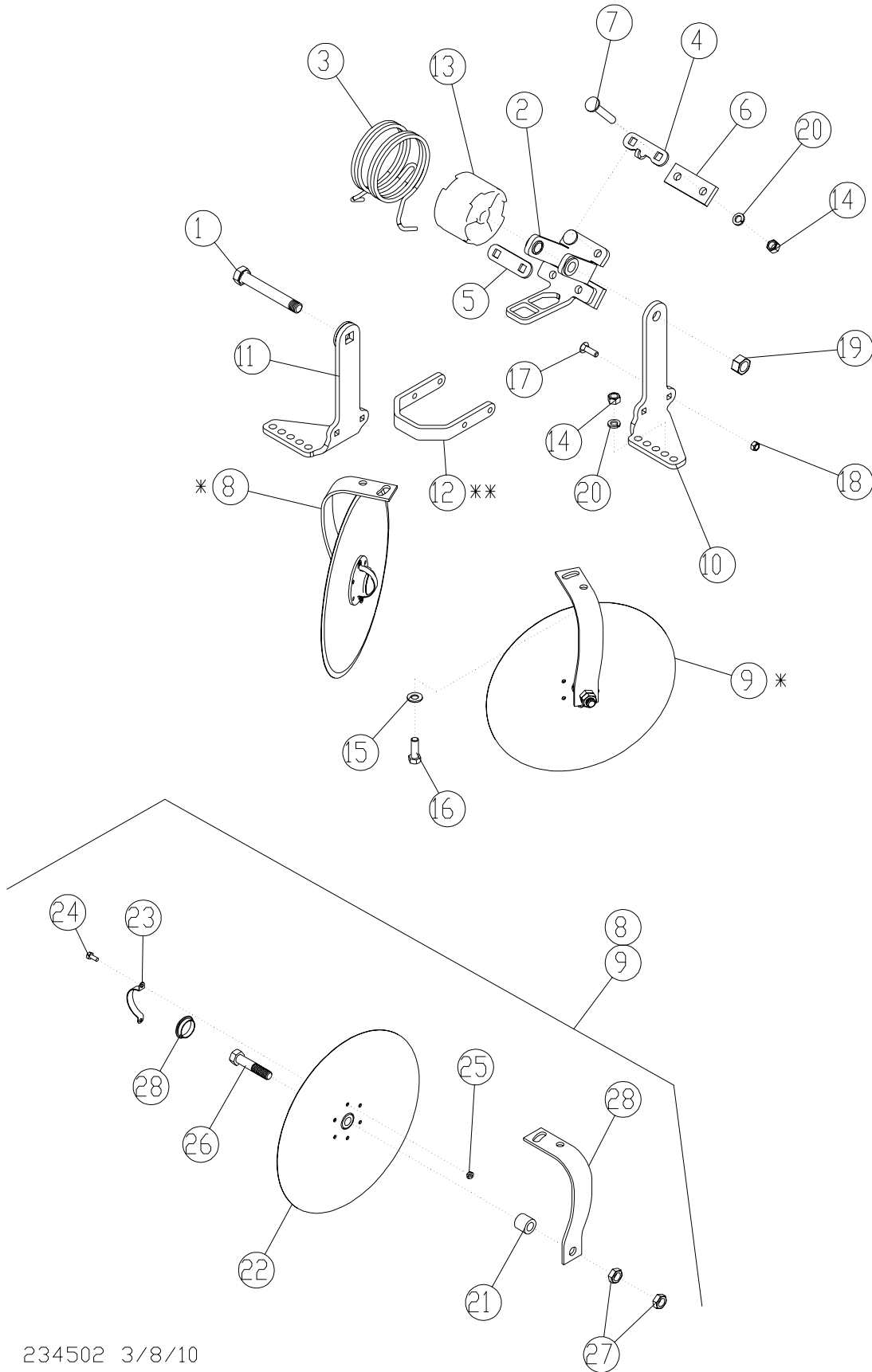

234502 3/8/10

DISC LEVELER - OPTIONAL

ITEM	PART NO.	DESCRIPTION	QTY
1	234504	BOLT-HEX: .50 X 5.75 NC GR5 ZP	1
2	66477	ASSY-CENTER CARRIER	1
3	67206	SPRING-TORSION .250 OTII	1
4	67208	HOLDER-SPRING ZP	1
5	67209	SPACER-DISC LEVELER ZP	1
6	67133	PLATE-BACKING ZP	2
7	67402	BOLT-CARR: .50-13 X 3.00 1.50 THREAD ZP	4
8	66478*	ASSY-LH DISC ARM	1
9	66479*	ASSY-RH DISC ARM	2
10	67132	ARM LONG LEFT	1
	234506	ARM SHORT LEFT	
11	67131	WLDMT-ARM LONG RIGHT	1
	234509	WLDMT-ARM SHORT RIGHT	
12	234513	STRAP-GUARD	1
	234520**	STRAP-EXTENDED GUARD	
13	67409	SPACER-CENTER CARRIER	1
14	1011577	NUT-HEX: .50 NC ZP	4
15	33036	WASHER-FLAT: .50 ZP HD	4
16	1011606	BOLT-HEX: .50 X 1.25 NC GR5 ZP	1
17	1016362	BOLT-CRG: .38 X 1.25 NC GR5 ZP	1
18	1016999	NUT-TOPLOCK: .38 NC GR5 ZP	1
19	1013537	NUT-TOPLOCK .75 NC GR5 ZP	1
20	1011581	WASHER-LOCK: .50 ZP	8
21	234516	TUBE-SPACER	2
22	234965	ASSY-DISC BLADE	2
23	234517	RETAINER-DUST CAP	2
24	66834	BOLT-HEX: .25 X .63 NC GR5	6
25	1013427	NUT-CENTERLOCK	6
26	1011624	BOLT-HEX: .63 X 3.00 NC GR5 ZP	2
27	1026259	NUT-JAM: .63 NC GR2 ZP	4
28	234515	SPRING-ARM DISC RH	1
	234514	SPRING-ARM DISC LH	1
29	66057	CAP-DUST	2

*ITEMS 21-29 ARE COMPONENTS OF ITEMS 8 & 9

**234520 IS A LONGER STRAP FOR DUAL SHOOT CONFIGURATIONS

4 BOLT PACKER HUB & SPINDLE - THRU 2008

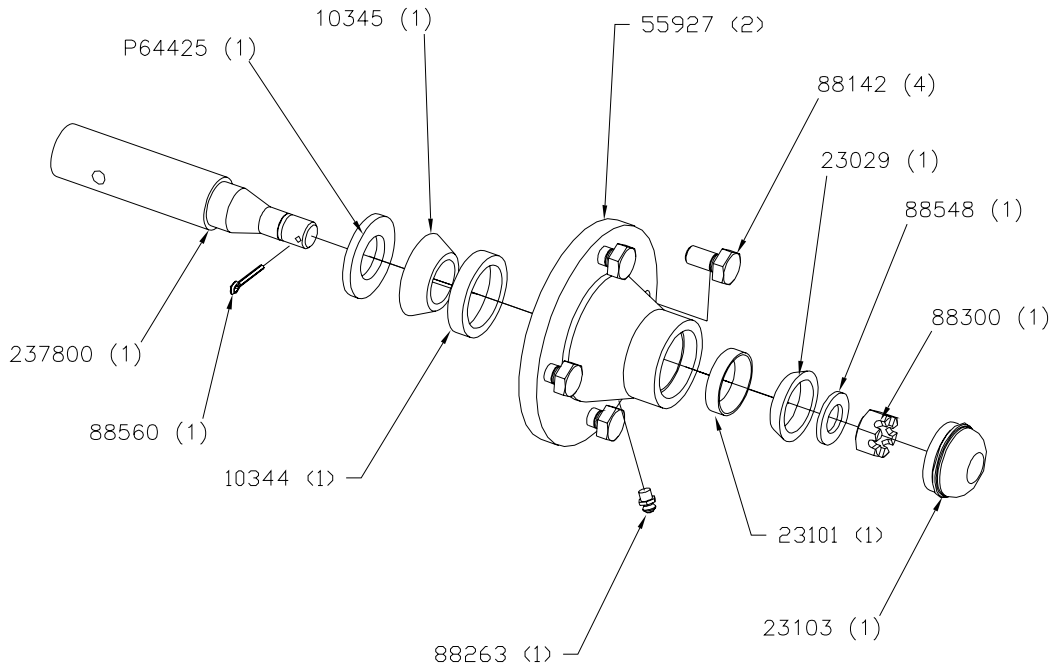

240482 - COMPLETE HUB & SPINDLE ASSY PAINTED BLACK

PART NO.	DESCRIPTION	QTY
10344	BEARING CUP 2.328 OD (LM67010)	1
10345	BEARING CONE 1-1/4ID (LM67048)	1
23029	BEARING CONE 3/4ID (LM11949)	1
P64425	SEAL	1
23101	BEARING CUP 25/32OD (LM11910)	1
23103	DUST CAP	1
237800	PACKER WHEEL SPINDLE	1
55927	4 BOLT WHEEL HUB (58054)	1
58054	4 BOLT PRESSED HUB	1
88142	BLT WHL 1/2-20NFX1 (13/16 HEAD)	4
88300	NUT SLTD 3/4-16NF 5Z	1
88548	WSHR FLAT 3/4SAE(13/16X1-1/2) Z	1
88560	PIN COT 1/8DIAX1-1/4 Z	1

4 BOLT PACKER HUB & SPINDLE - 2009 & LATER

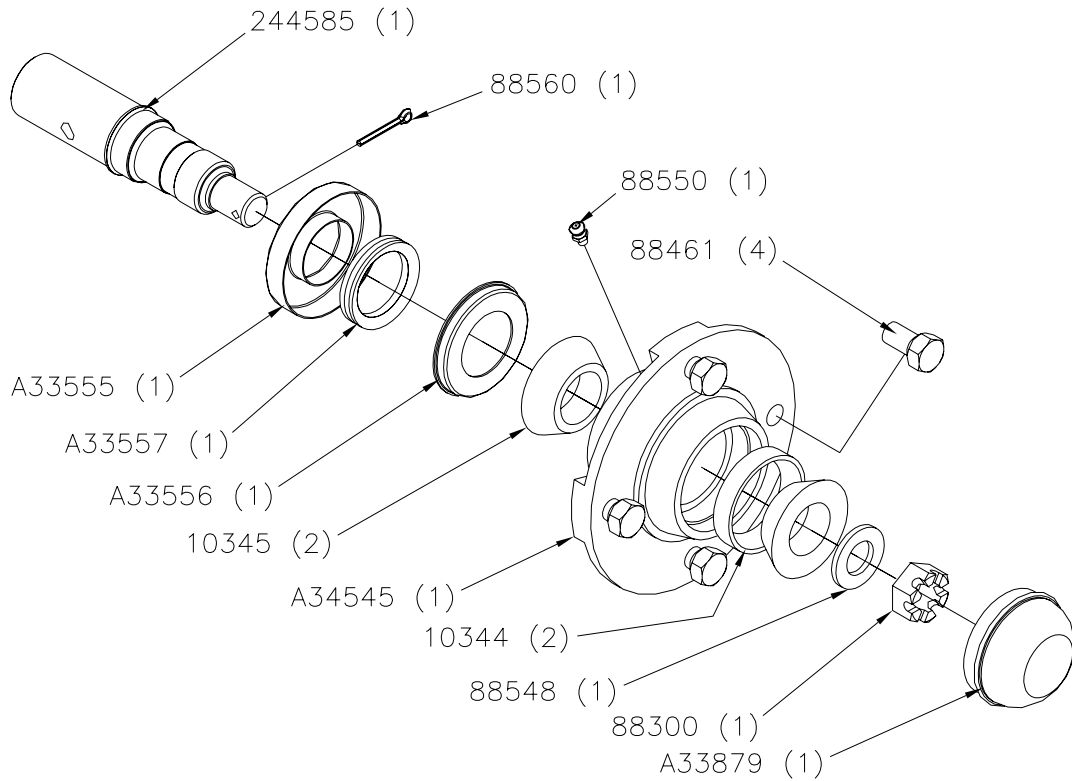

243985 - COMPLETE HUB & SPINDLE ASSY PAINTED BLACK

PART NO.	DESCRIPTION	QTY
10344	BEARING CUP 2.328 OD (LM67010)	2
10345	BEARING CONE 1-1/4ID (LM67048)	2
244585	PACKER SPINDLE	1
88300	NUT SLTD 3/4-16NF 5Z	1
89461	BLT-WHL 1/2-20 UNF X .75	4
88548	WSHR FLAT 3/4SAE(13/16X1-1/2) Z	1
88550	FTG GRS 1/4-28 3038-B	1
88560	PIN COT 1/8DIAX1-1/4 Z	1
A33555	SEAL RETAINER	1
A33556	SEAL COUNTERFACE	1
A33557	V-SEAL	1
A33879	HUB CAP	1
A34545	PACKER HUB	1

4 BOLT PACKER HUB & SPINDLE

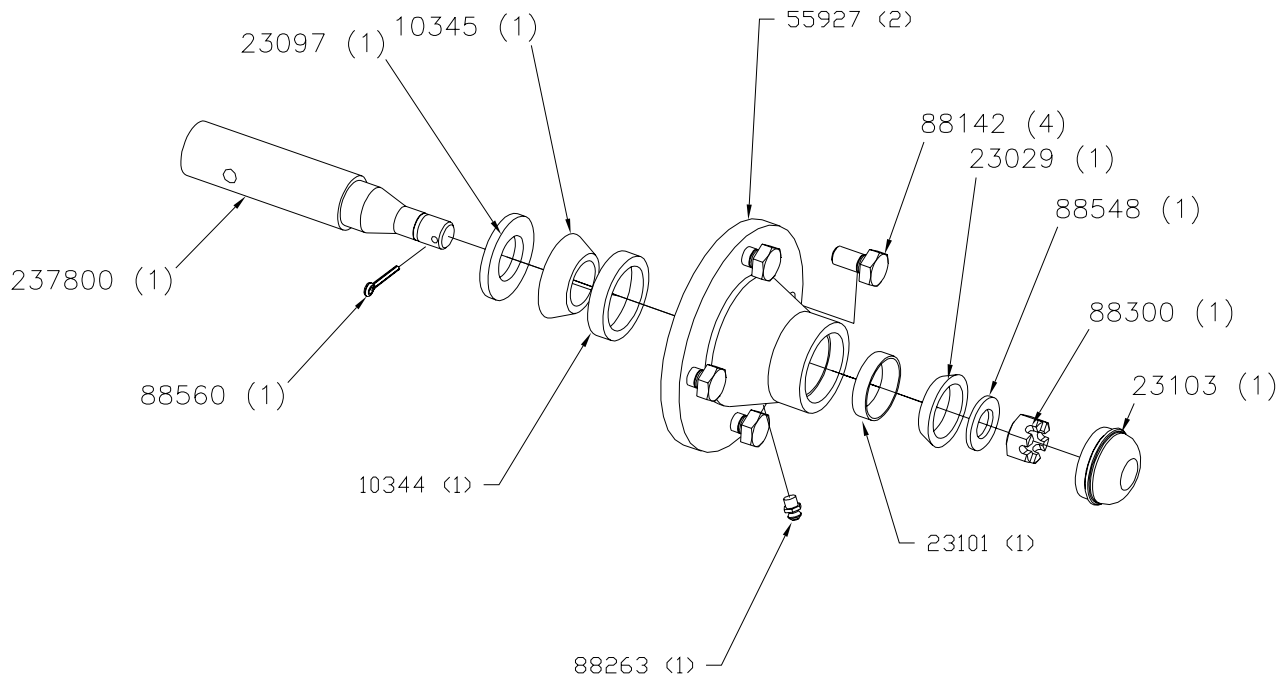

PART NO.	DESCRIPTION	QTY
10344	BEARING CUP 2.328 OD (LM67010)	1
10345	BEARING CONE 1-1/4ID (LM67048)	1
23029	BEARING CONE 3/4ID (LM11949)	1
23097	SEAL	1
23101	BEARING CUP 25/32OD (LM11910)	1
23103	DUST CAP	1
237800	PACKER WHEEL SPINDLE	1
55927	4 BOLT WHEEL HUB (58054)	1
58054	4 BOLT PRESSED HUB	1
88142	BLT WHL 1/2-20NFX1 (13/16 HEAD)	4
88300	NUT SLTD 3/4-16NF 5Z	1
88548	WSHR FLAT 3/4SAE(13/16X1-1/2) Z	1
88560	PIN COT 1/8DIA X 1-1/4 Z	1

6-BOLT HUB & 2" SPINDLE

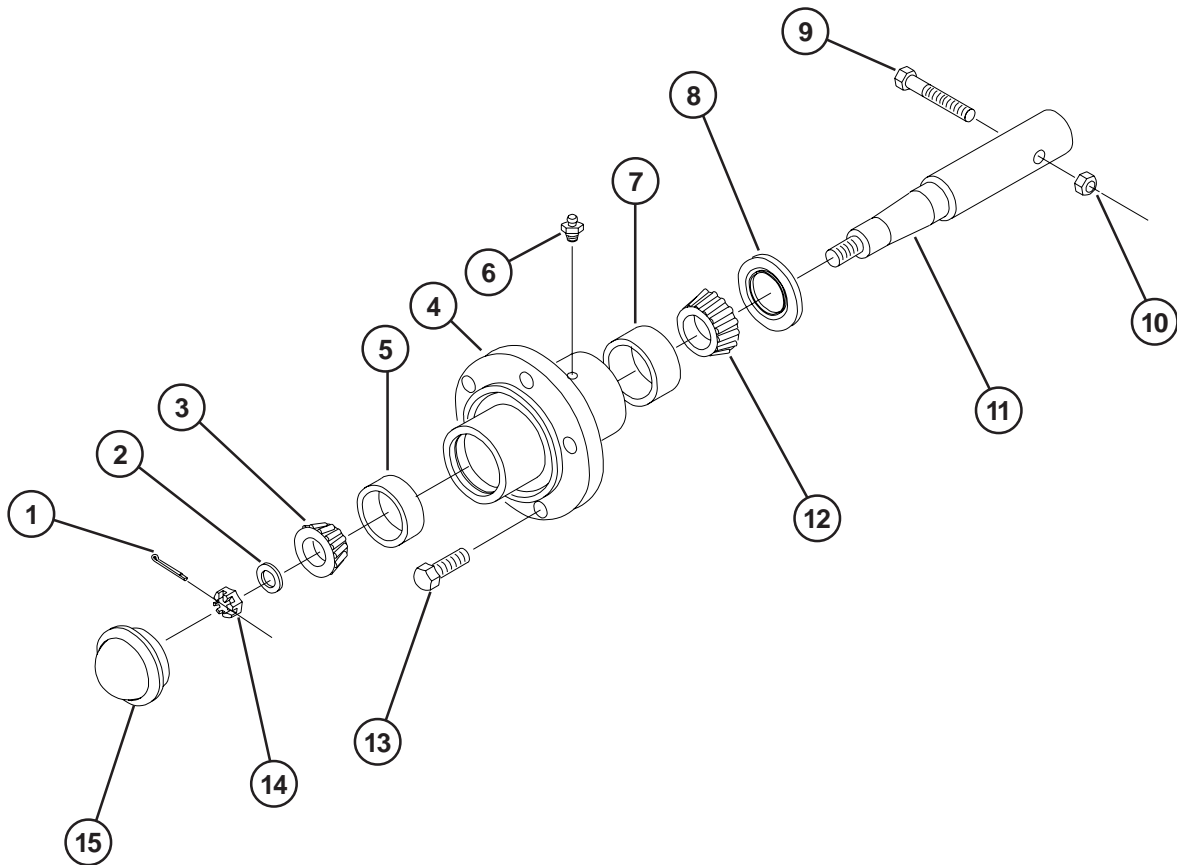

77836.PLT

ITEM PART NO. DESCRIPTION

	14131	2" HUB & SPINDLE ASSY (INCLUDES 1-8 & 11-15)
1	88301	PIN COT 3/16DIAx1-1/2
2	16094	SPINDLE WASHER 7/8ID
3	10345	BEARING CONE 1-1/4ID (LM67048)
4	24097	6-BOLT HUB W/CUPS
5	10344	BEARING CUP 2.328 OD (LM67010)
6	88263	FTG GRS 1/8NPT 1610-BL(11/16")
7	14249	BEARING CUP 2.891 OD (LM501310)
8	58546	2" TRIPLE LIP SEAL
9	88429	1/2NFx3-1/4 GR5 BOLT
10	88304	NUT 2POSLK 1/2NF
11	14251	2" AXLE SPINDLE
12	14248	BEARING CONE 1-5/8ID (LM501349)
13	88142	WHEEL BOLT 1/2NFx1 (13/16 HEAD)
14	88340	NUT SLTD 7/8NF
15	11381	DUST CAP

8-BOLT HUB & 2-1/2" SPINDLE

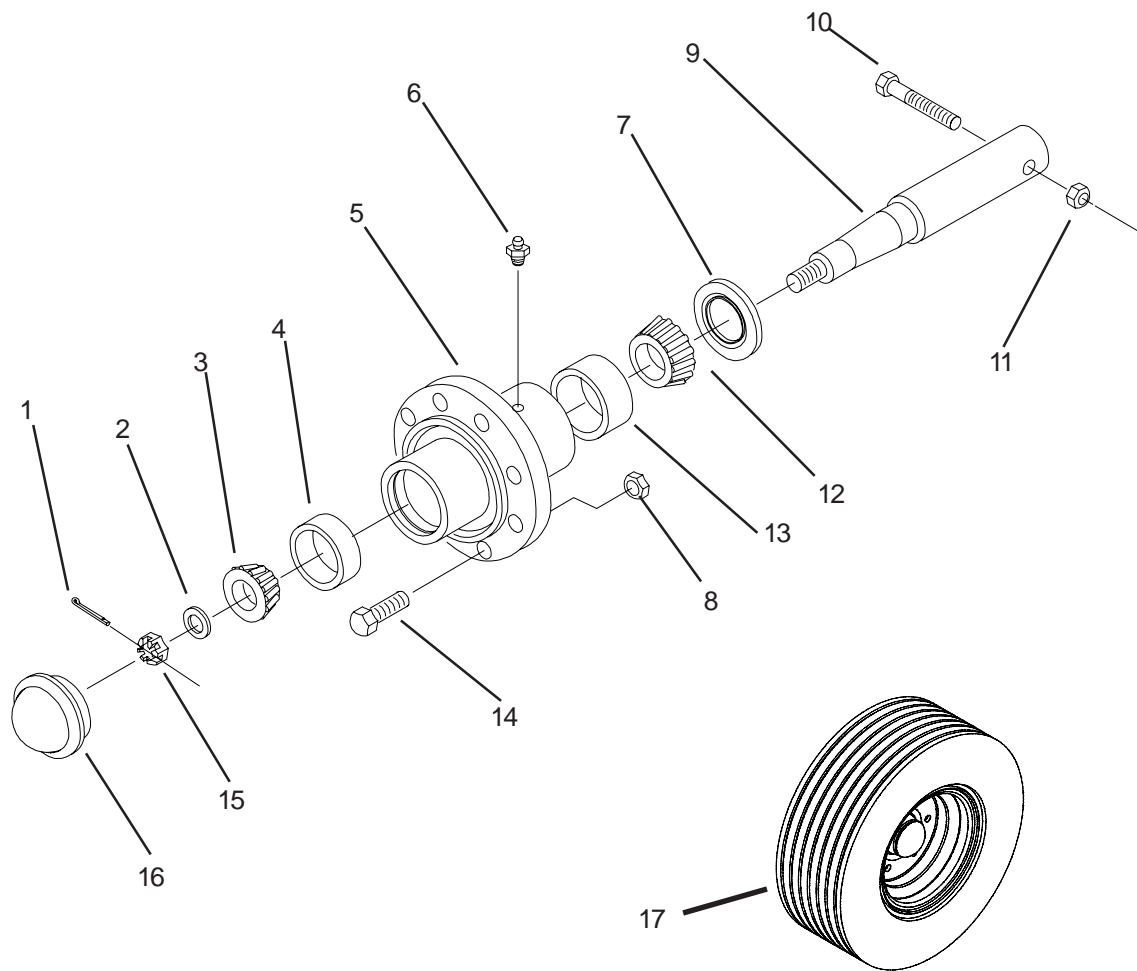

78195A

ZE

ITEM	PART NO	DESCRIPTION	ITEM	PART NO	DESCRIPTION
	16154	8-BOLT HUB & SPINDLE (RED) (INCLUDES ITEMS 1-7,9,12-16)	9	16156	2-1/2" AXLE SPINDLE (14-3/4)
1	88301	3/16x1-1/2 COTTER PIN	10	88298	5/8NCx4 GR5 BOLT
2	64050	2-1/2ODx1-1/16ID SPINDLE WASHER	11	88369	5/8NC LOCK NUT
3	16081	OUTER BEARING CONE (TIMKEN# 2790)	12	16083	INNER BEARING CONE (TIMKEN# 3780)
4	16082	OUTER BEARING CUP (TIMKEN# 2720)	13	16084	INNER BEARING CUP (TIMKEN# 3720)
5	41054	8-BOLT PRESSED HUB (RED) (INCLUDES ITEMS 4, 6 & 12)	14	63831	9/16NFx1-1/8 90° WHEEL BOLT
6	88143	1/4NPT GREASE FITTING	15	88299	1NF SLOTTED NUT
7	235298	2-1/2" SINGLE LIP SEAL	16	16077	DUST CAP
8	89458	9/16NF JAM NUT	17	222259	31x13.5 12 PLY 8 BOLT WHEEL ASSY
				203196	15x10 WHEEL RIM
				57908	VALVE ASSEMBLY
				222088	31x13.5 12PLY TIRE

MAIN LIFT BYPASS CYLINDER CIRCUIT

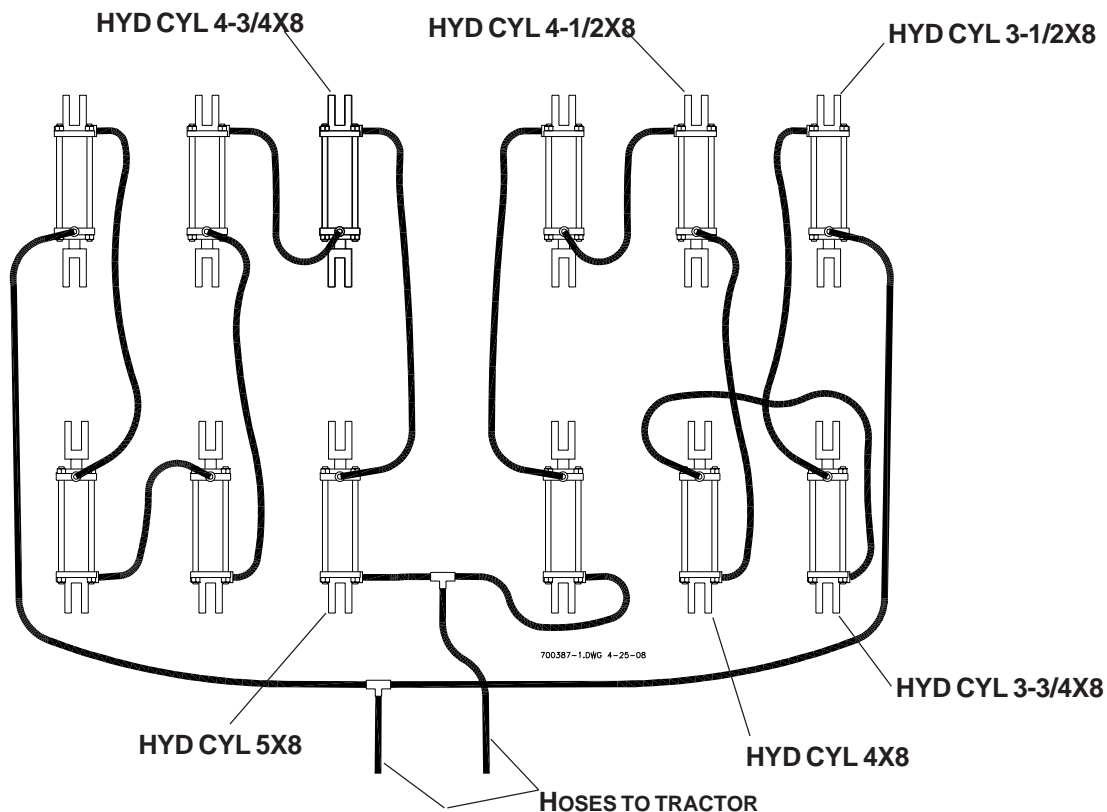

REFER TO PAGE 43 FOR CYLINDER LOCATIONS ON THE MAIN UNIT, NOTE ORIENTATION OF FRONT CYLINDERS ON THE LEFT SIDE OF THE UNIT. ILLUSTRATION SHOWS 50FT & 60FT UNIT, 40FT UNIT DOES NOT USE THE

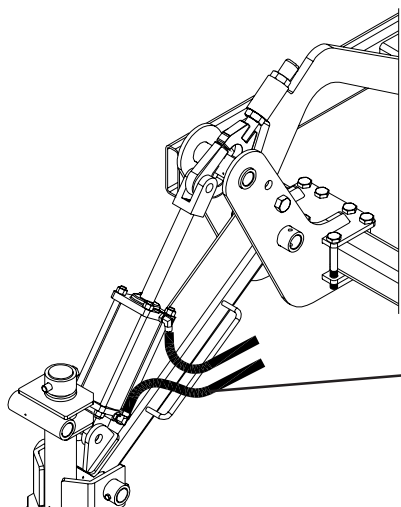

NOTE: CYLINDERS ON FRONT LIFT AXLES AND REAR PACKER LIFTS MUST BE MOUNTED WITH RODS UP AND PORTS TO THE SIDE. REMOVE AND ROTATE END GLANDS IF REQUIRED. FAILURE TO ORIENTATE AS INDICATED CAN CAUSE PORT INTERFERENCE, CHECK FOR INTERFERENCE BEFORE AND WHILE ACTIVATING ALL CYLINDERS.

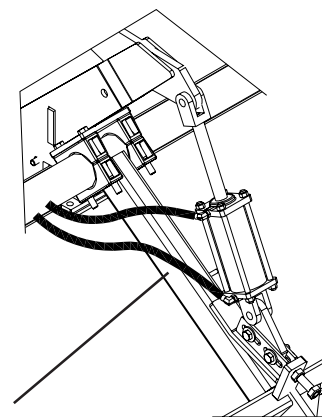

700388.DWG 7/11/07

CYLINDER LOCATIONS

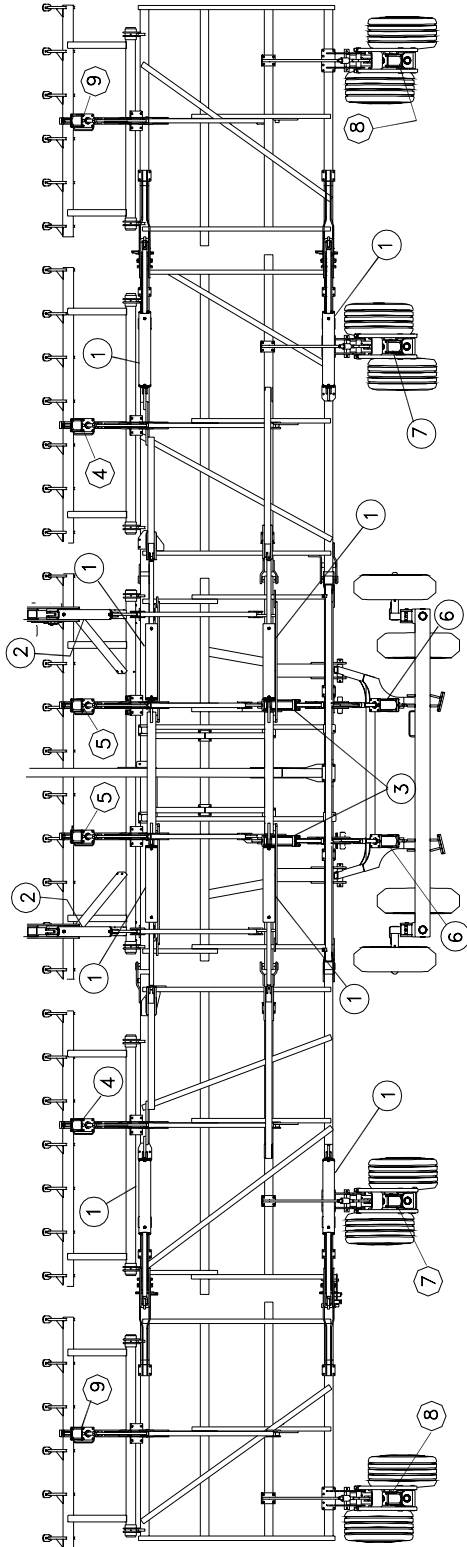

40 FT UNIT DOES NOT REQUIRE 3-3/4X8
OR 3-1/2X8 LIFT CYLINDERS

ITEM #	PART NO.	DESCRIPTION	60' QTY	40' QT
1	20966F	HYD CYL 5X30 FGS #A519CY07	8	4
2	222213F1	HYD CYL 4X16 FGS #A519CY26	2	2
3	234764	HYD CYL 4" X 12" (BLACK)	2	2
4	241622	HYD CYL 4-1/2X8 SEQ	2	2
5	241623	HYD CYL 4-3/4X8 SEQ	2	2
6	241624	HYD CYL 5X8 SEQ	2	2
7	241663	HYD CYL 4X8 WITH SPACER	2	2
8	241664	HYD CYL 3-3/4X8 WITH SPACER	2	0
9	241665	HYD CYL 3-1/2X8 WITH SPACER	2	0

HYDRAULIC STOP COLLARS & SEAL KITS

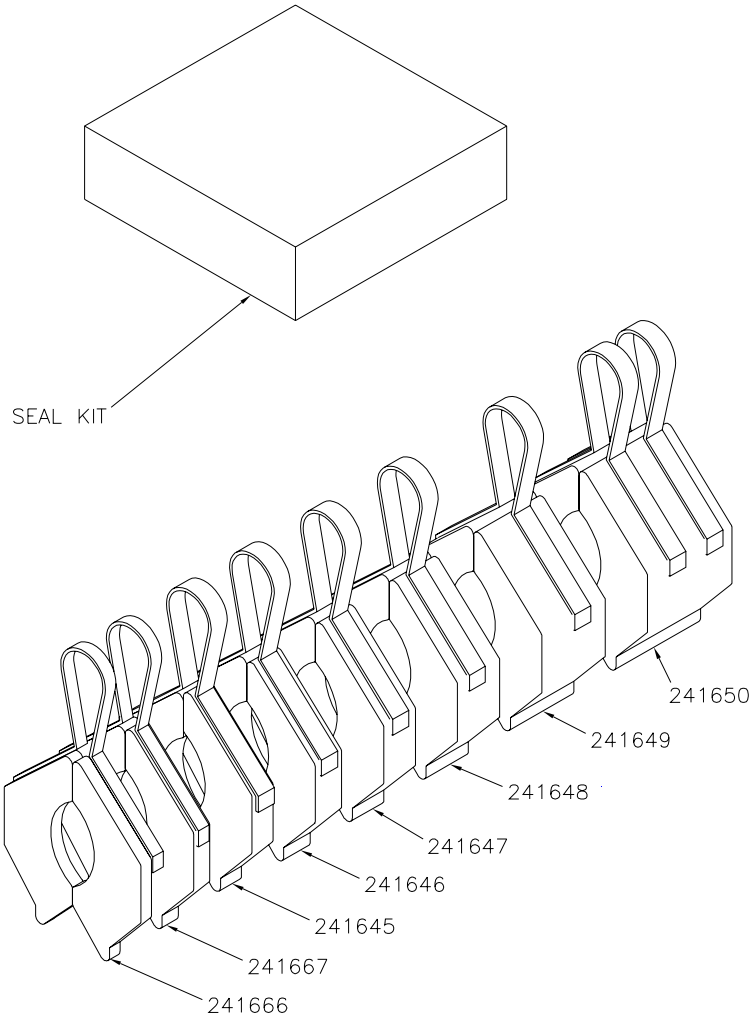

PART NO.	DESCRIPTION	PART NO.	DESCRIPTION
241621	MAIN LIFT STOP COLLAR KIT	241649	1-1/2IN CYLINDER STOP
241668	SEAL KIT 3-1/24IN ATD BP CYL	241650	2IN CYLINDER STOP
222038	SEAL KIT 4IN (4X12 CYL)	241666	1/4 IN CYLINDER STOP
233731	SEAL KIT 5IN (5X30CYL)	241667	3/8 IN CYLINDER STOP
233838	SEAL KIT 4IN (4X16 CYL)	241669	SEAL KIT 3-3/4IN ATD BP CYL
241645	1/2IN CYLINDER STOP	241670	SEAL KIT 4IN ATD BP CYL
241646	5/8IN CYLINDER STOP	241671	SEAL KIT 4-1/2IN ATD BP CYL
241647	3/4IN CYLINDER STOP	241672	SEAL KIT 4-3/4IN ATD BP CYL
241648	1IN CYLINDER STOP	241673	SEAL KIT 5IN ATD BP CYL

HOSE ROUTING-40' MAIN LIFT

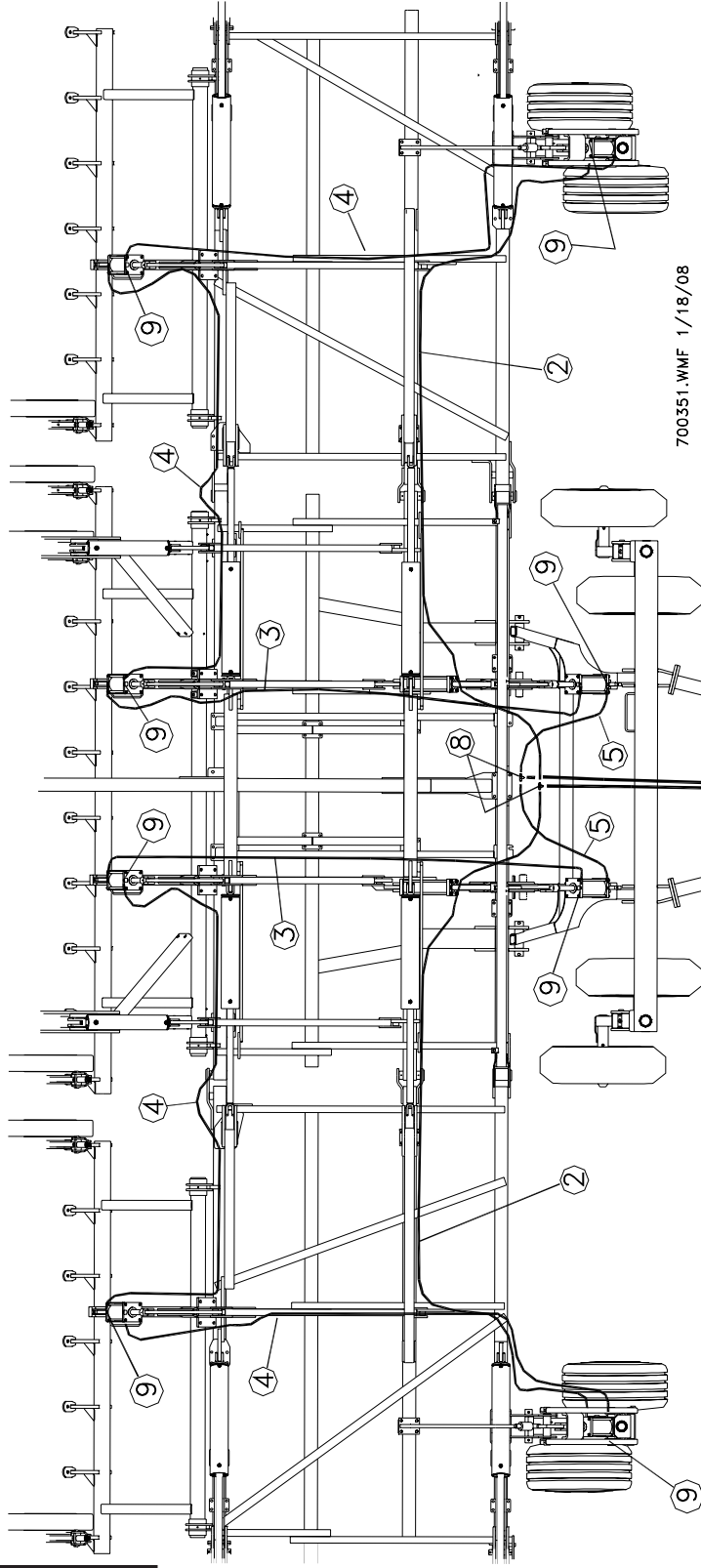

700351.WMF 1/18/08

**HDW KIT
74285-11**

ITEM #	PART NO.	DESCRIPTION	QTY
1	237264	HSE 3KPSI 1/2X237 8FJX-8FJX	2
2	233688	HSE 3KPSI 3/8X252 8FJX-8FJX	2
3	233689	HSE 3KPSI 3/8X180 8FJX-8FJX	2
4	234947	HSE 3KPSI 3/8X194 8FJX-8FJX	4
5	15515	HSE 3KPSI 3/8X62 8FJX-8FJX	2

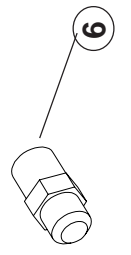
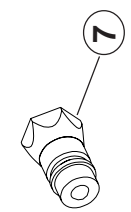

ITEM #	PART NO.	DESCRIPTION	QTY
6	13234	ADP 8MJ X 8MPT	2
7	60640	QUICK DISCONNECT COUPLER	2
8	13238	TEE 8MJ X 8MJ X 8MJ	2
9	25580	ELB 8MORB X 8MJ	16

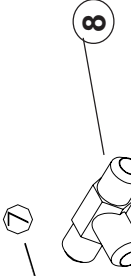
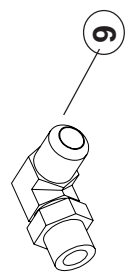

LIFT HOSE DECALS

HOSE ROUTING-40' WING FOLD

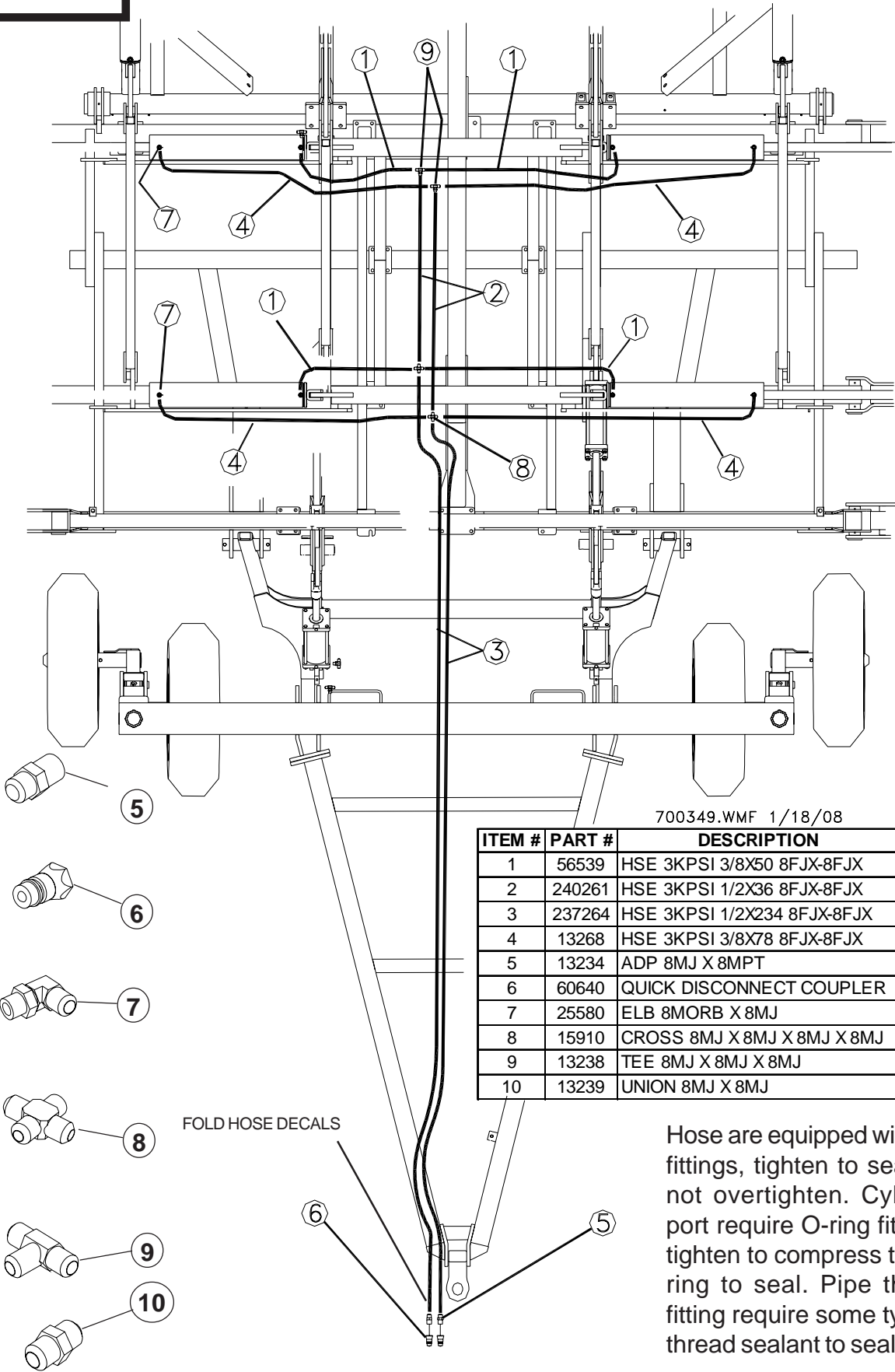

700349.WMF 1/18/08

ITEM #	PART #	DESCRIPTION	QTY/UNIT
1	56539	HSE 3KPSI 3/8X50 8FJX-8FJX	4
2	240261	HSE 3KPSI 1/2X36 8FJX-8FJX	4
3	237264	HSE 3KPSI 1/2X234 8FJX-8FJX	2
4	13268	HSE 3KPSI 3/8X78 8FJX-8FJX	4
5	13234	ADP 8MJ X 8MPT	2
6	60640	QUICK DISCONNECT COUPLER	2
7	25580	ELB 8MORB X 8MJ	8
8	15910	CROSS 8MJ X 8MJ X 8MJ X 8MJ	2
9	13238	TEE 8MJ X 8MJ X 8MJ	2
10	13239	UNION 8MJ X 8MJ	2

Hose are equipped with JIC fittings, tighten to seal, do not overtighten. Cylinder port require O-ring fittings, tighten to compress the O-ring to seal. Pipe thread fitting require some type of thread sealant to seal.

HOSE ROUTING - 40'/50'/60' TRANSPORT LIFT

**HDW KIT
74285-13**

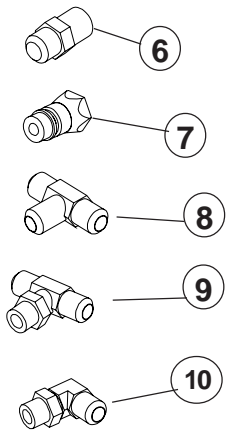
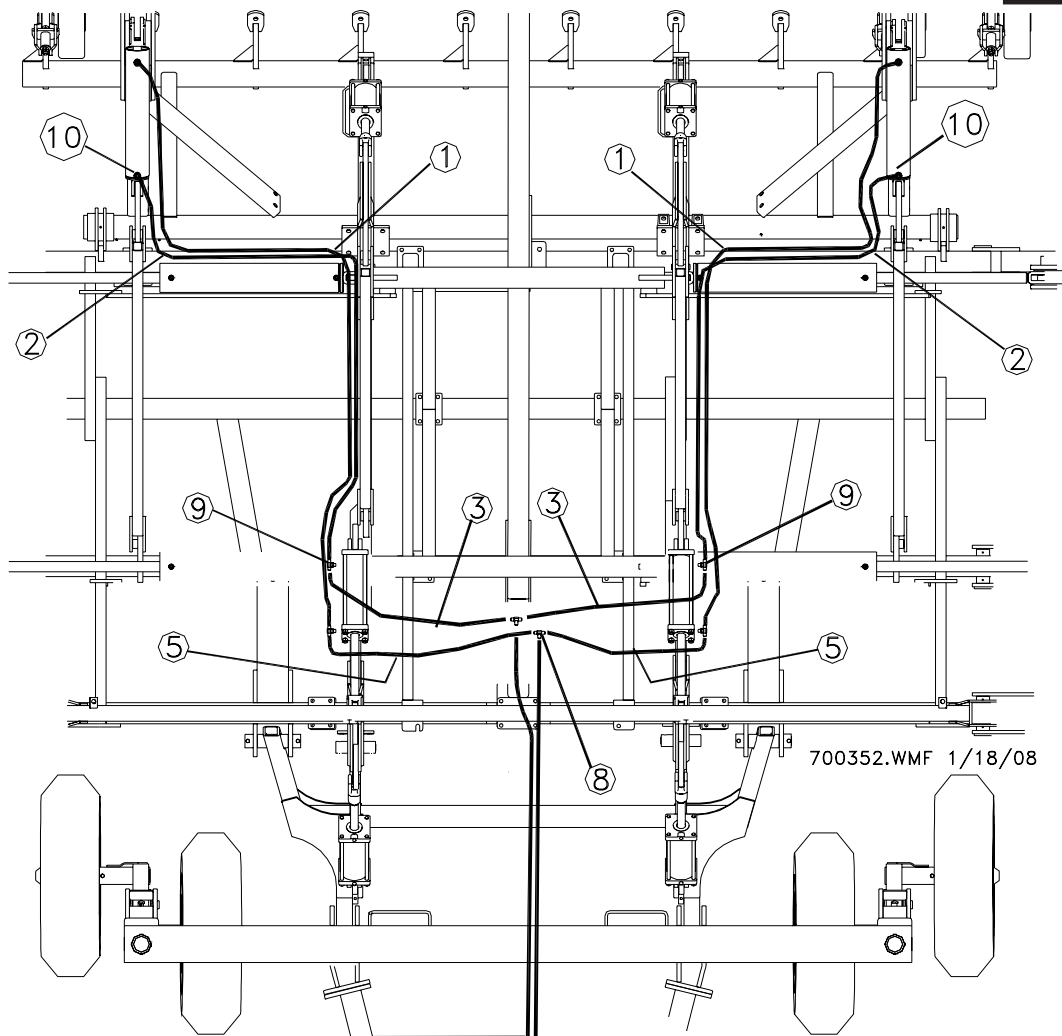

ITEM #	PART #	DESCRIPTION	QTY
1	13484	HSE 3KPSI 3/8X156 8FJX-8FJX	2
2	67634	HSE 3KPSI 3/8X132 8FJX-8FJX	2
3	15515	HSE 3KPSI 3/8X62 8FJX-8FJX	2
4	237264	HSE 3KPSI 1/2X234 8FJX-8FJX	2
5	56539	HSE 3KPSI 3/8X50 8FJX-8FJX	2
6	13234	ADP 8MJ X 8MPT	2
7	60640	QUICK DISCONNECT COUPLER	2
8	13238	TEE 8MJ X 8MJ X 8MJ	2
9	56534	TEE 8MJ X 8MJ X 8MORB	4
10	25580	ELB 8MORB X 8MJ	4

Hose are equipped with JIC fittings, tighten to seal, do not overtighten. Cylinder port require O-ring fittings, tighten to compress the O-ring to seal. Pipe thread fitting require some type of

HOSE ROUTING-50'/60' WING FOLD

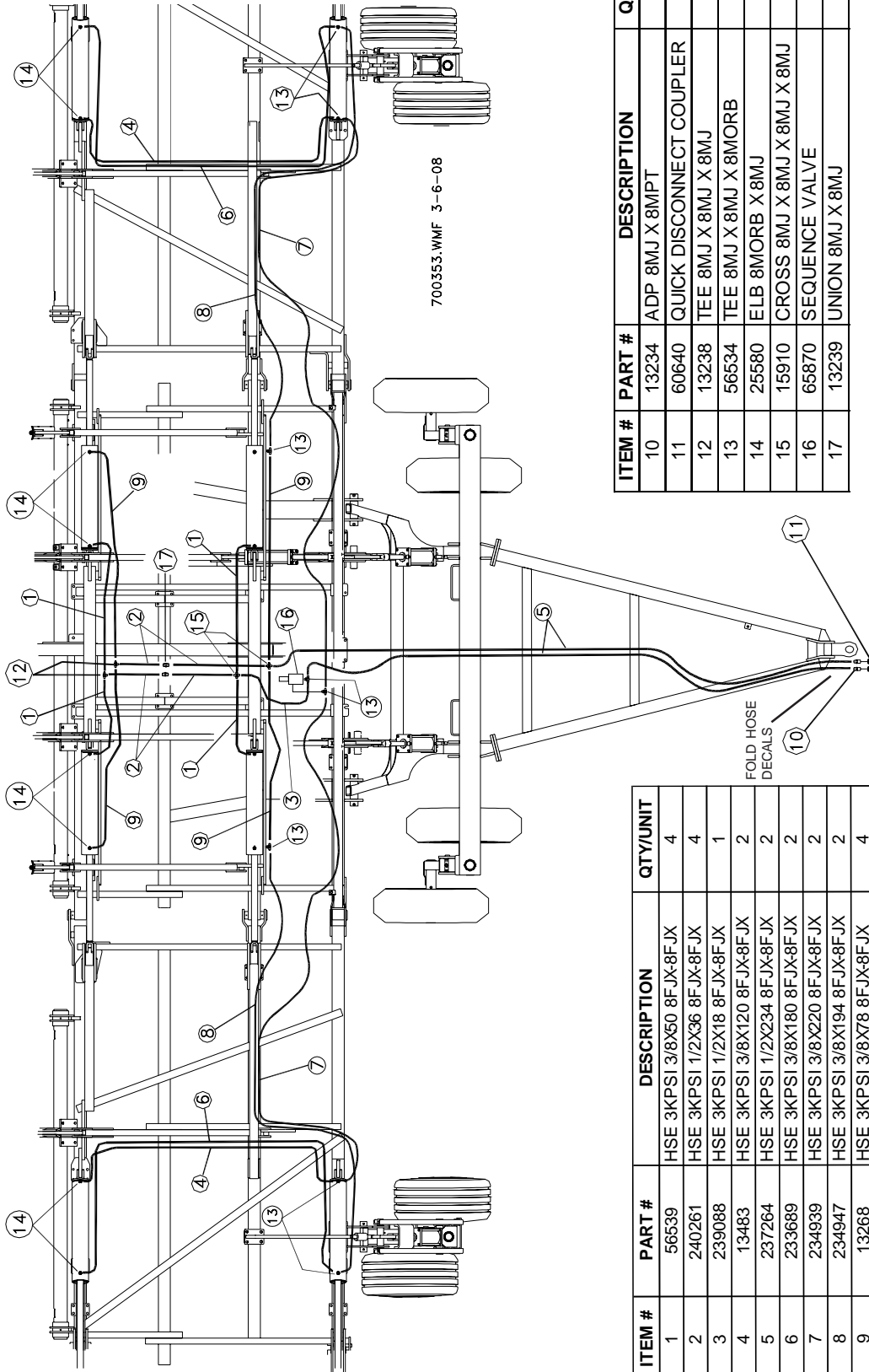

ITEM #	PART #	DESCRIPTION	QTY/UNIT
10	13234	ADP 8MJ X 8MPT	2
11	60640	QUICK DISCONNECT COUPLER	2
12	13238	TEE 8MJ X 8MJ X 8MJ	2
13	56534	TEE 8MJ X 8MJ X 8MORB	8
14	25580	ELB 8MORB X 8MJ	10
15	15910	CROSS 8MJ X 8MJ X 8MJ X 8MJ	2
16	65870	SEQUENCE VALVE	1
17	13239	UNION 8MJ X 8MJ	2

ITEM #	PART #	DESCRIPTION	QTY/UNIT
1	56539	HSE 3KPSI 3/8X50 8F-JX-8F-JX	4
2	240261	HSE 3KPSI 1/2X36 8F-JX-8F-JX	4
3	239088	HSE 3KPSI 1/2X18 8F-JX-8F-JX	1
4	13483	HSE 3KPSI 3/8X120 8F-JX-8F-JX	2
5	237264	HSE 3KPSI 1/2X234 8F-JX-8F-JX	2
6	233689	HSE 3KPSI 3/8X180 8F-JX-8F-JX	2
7	234939	HSE 3KPSI 3/8X220 8F-JX-8F-JX	2
8	234947	HSE 3KPSI 3/8X194 8F-JX-8F-JX	2
9	13268	HSE 3KPSI 3/8X78 8F-JX-8F-JX	4

Set sequence valve (16) by adjusting valve screw to control the extension of the outer wing fold cylinders. Turn adjust screw counter-clockwise from factory setting to retard the inner wing fold cylinders until outer wing fold cylinders are totally extended.

Hose are equipped with JIC fittings, tighten to seal, do not overtighten. Cylinder port require O-ring fittings, tighten to compress the O-ring to seal. Pipe thread fitting require some type of

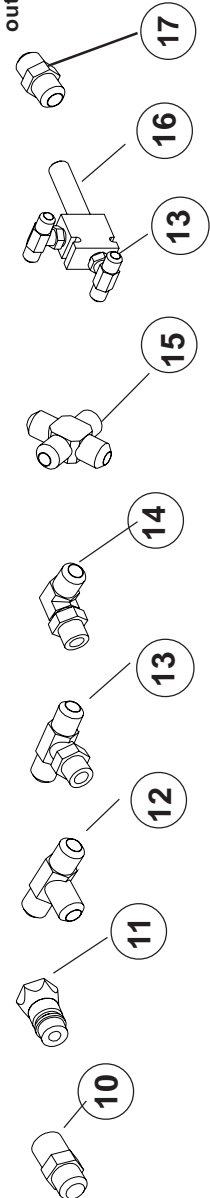

HOSE ROUTING - 50'/60' MAIN LIFT

**HDW KIT
74285-15**

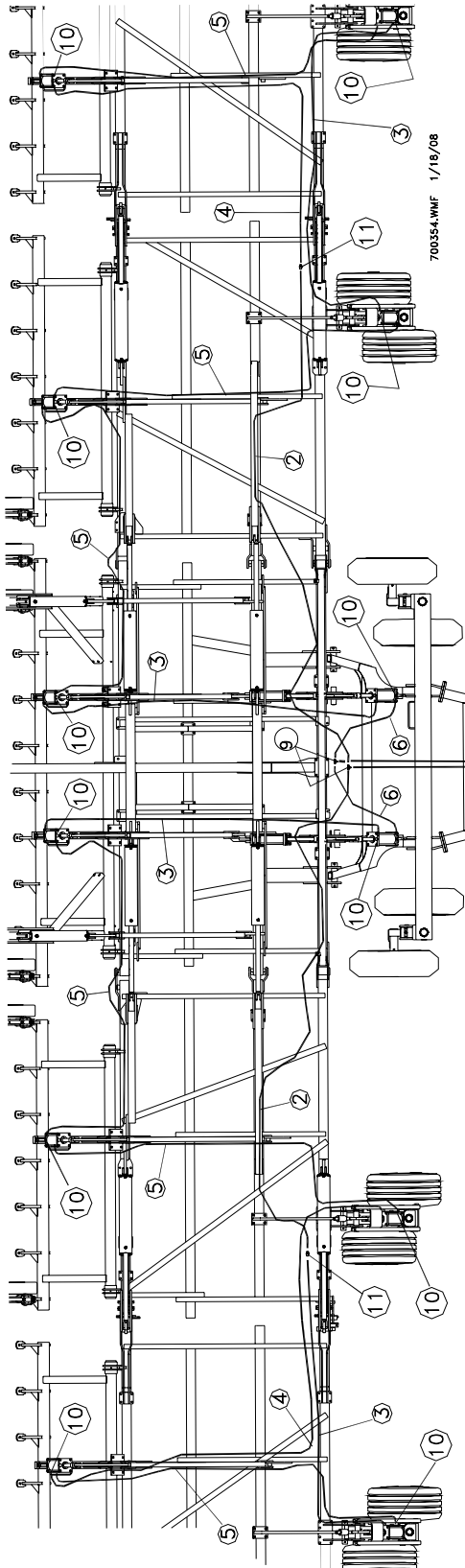

LIFT HOSE DECALS

ITEM #	PART #	DESCRIPTION	QTY/UNIT
7	13234	ADP 8MJ X 8MPT	2
8	60640	QUICK DISCONNECT COUPLER	2
9	13238	TEE 8MJ X 8MJ X 8MJ	2
10	25580	ELD 8MORB X 8MJ	24
11	13239	APD UNION 8MJ X8MJ	2

ITEM #	PART #	DESCRIPTION	QTY/UNIT
1	237264	HSE 3KPSI 1/2X234 8FJX-8FJX	2
2	233688	HSE 3KPSI 3/8X252 8FJX-8FJX	2
3	233689	HSE 3KPSI 3/8X180 8FJX-8FJX	4
4	234939	HSE 3KPSI 3/8X220 8FJX-8FJX	2
5	234947	HSE 3KPSI 3/8X194 8FJX-8FJX	6
6	15515	HSE 3KPSI 3/8X62 8FJX-8FJX	2

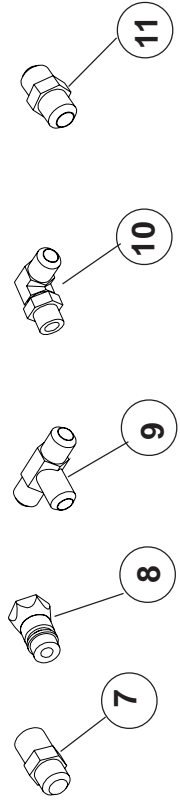

Hose are equipped with JIC fittings, tighten to seal, do not overtighten. Cylinder port require O-ring fittings, tighten to compress the O-ring to seal. Pipe thread fitting require some type of thread sealant to seal.

HOSE ROUTING - AIR SEEDER

**HDW KIT
74285-11**

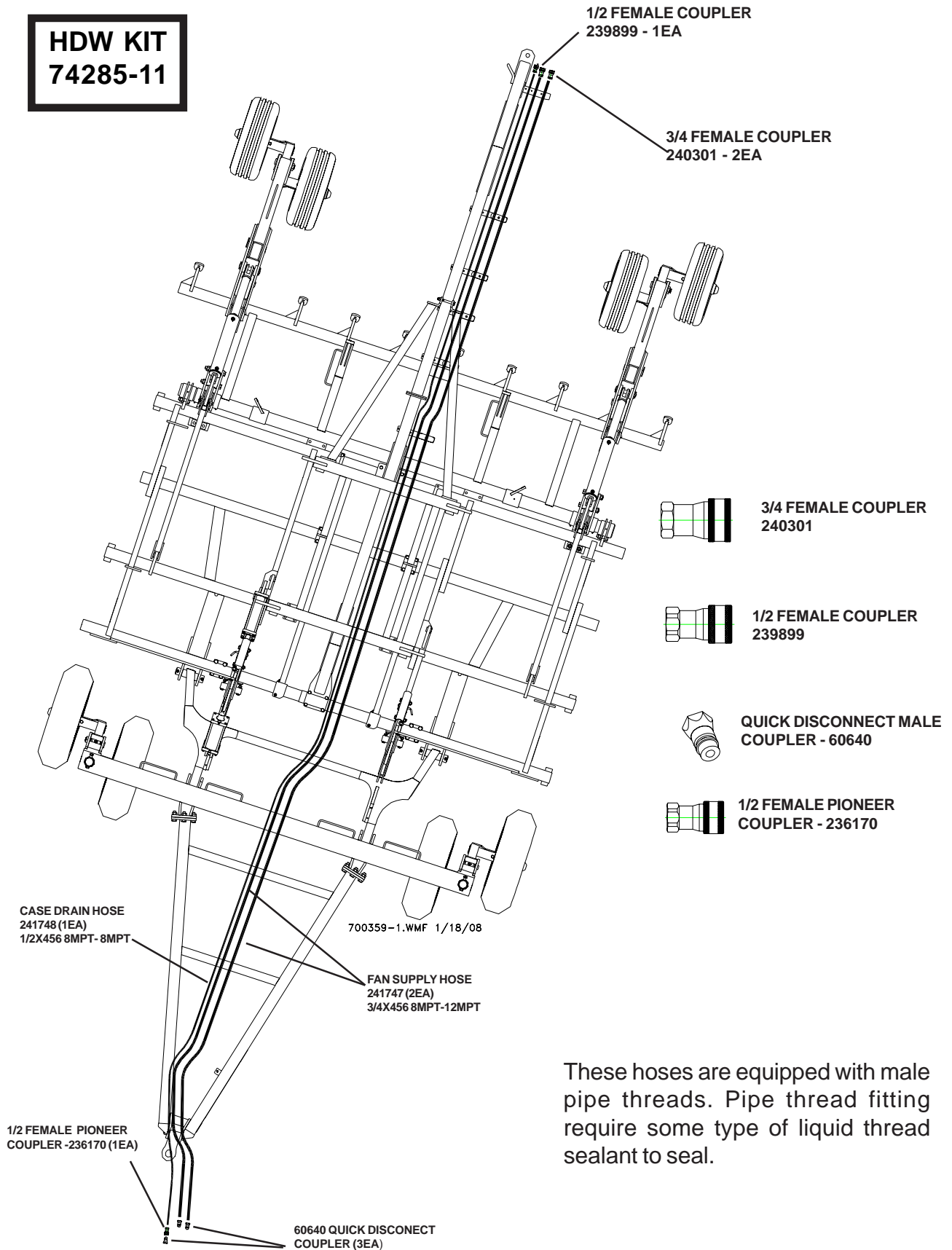

RIGHT SIDE SHANK SPACINGS - 40'/60'

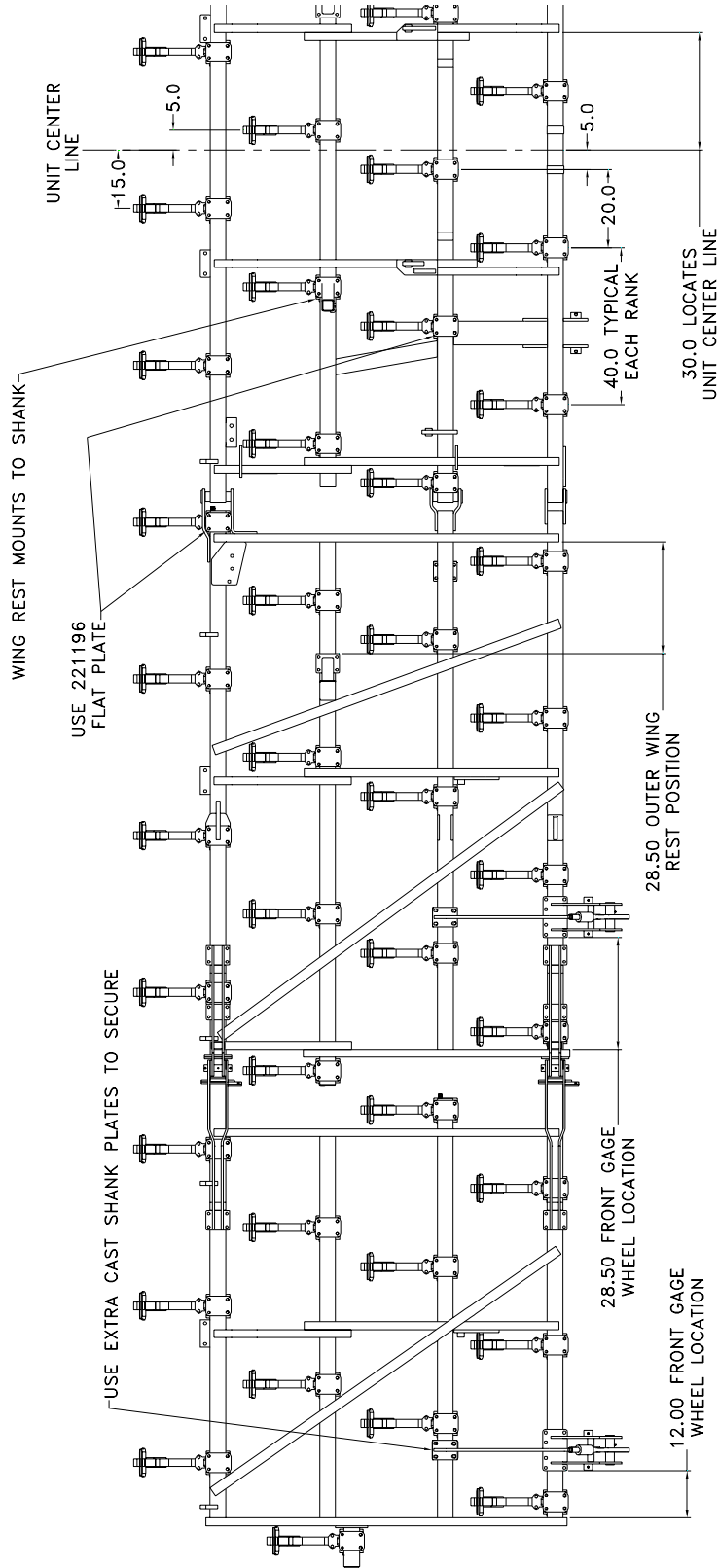

700355MOD-1.WMF

LEFT SIDE SHANK SPACINGS - 40'/60'

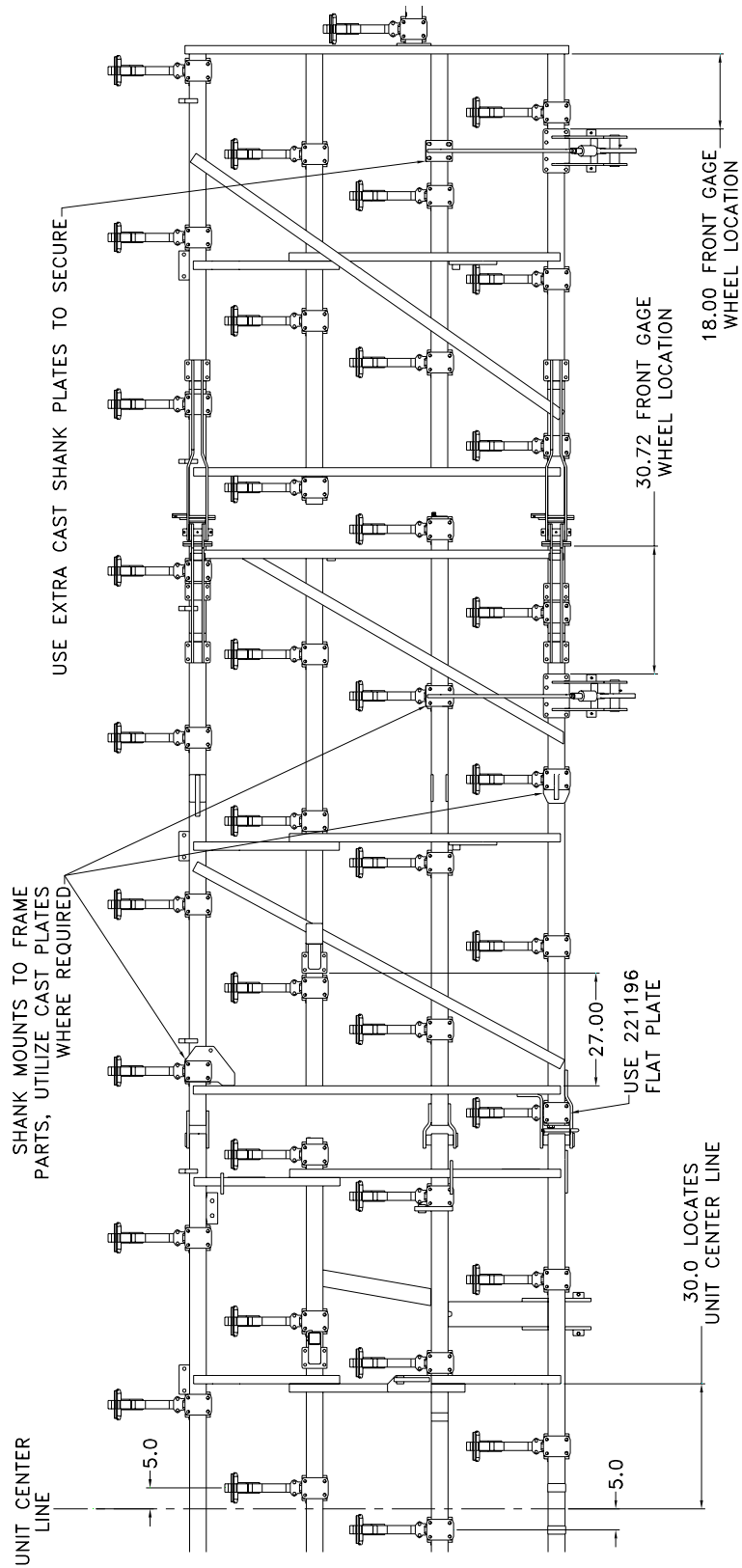

RIGHT SIDE SHANK SPACINGS - 50'

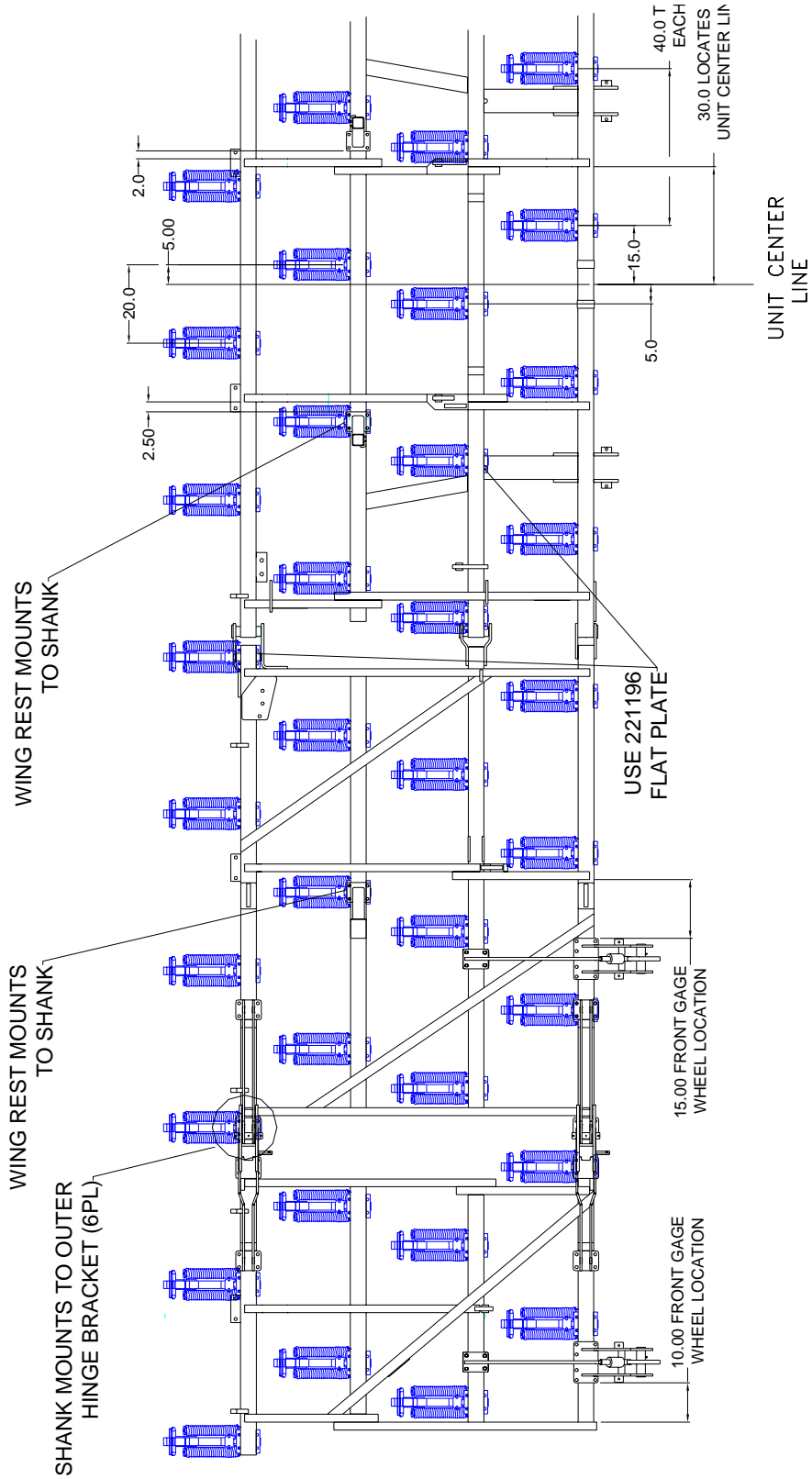

LEFT SIDE SHANK SPACINGS - 50'

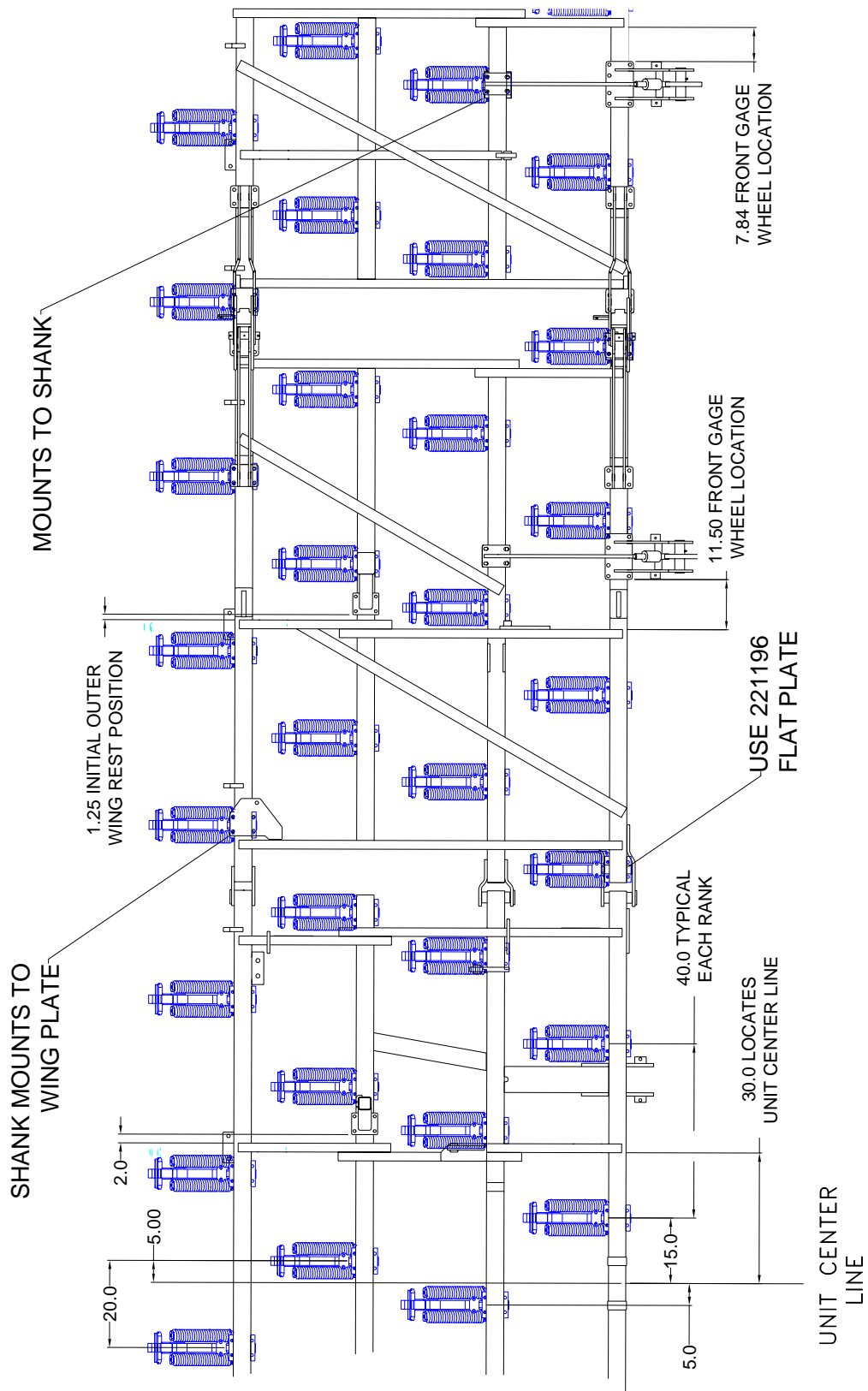

DECAL LOCATIONS/GREASE FITTINGS - 40'/60'

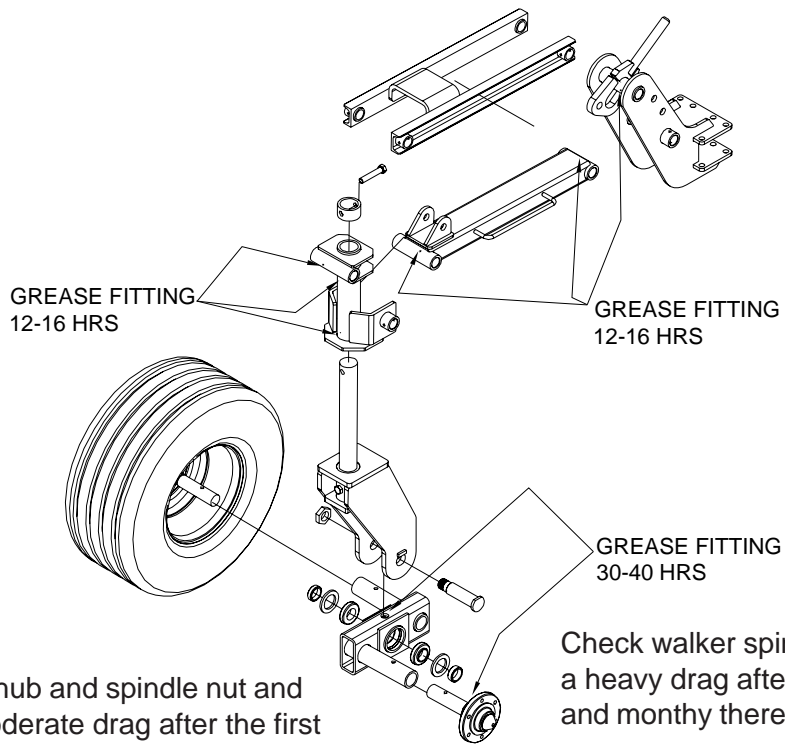
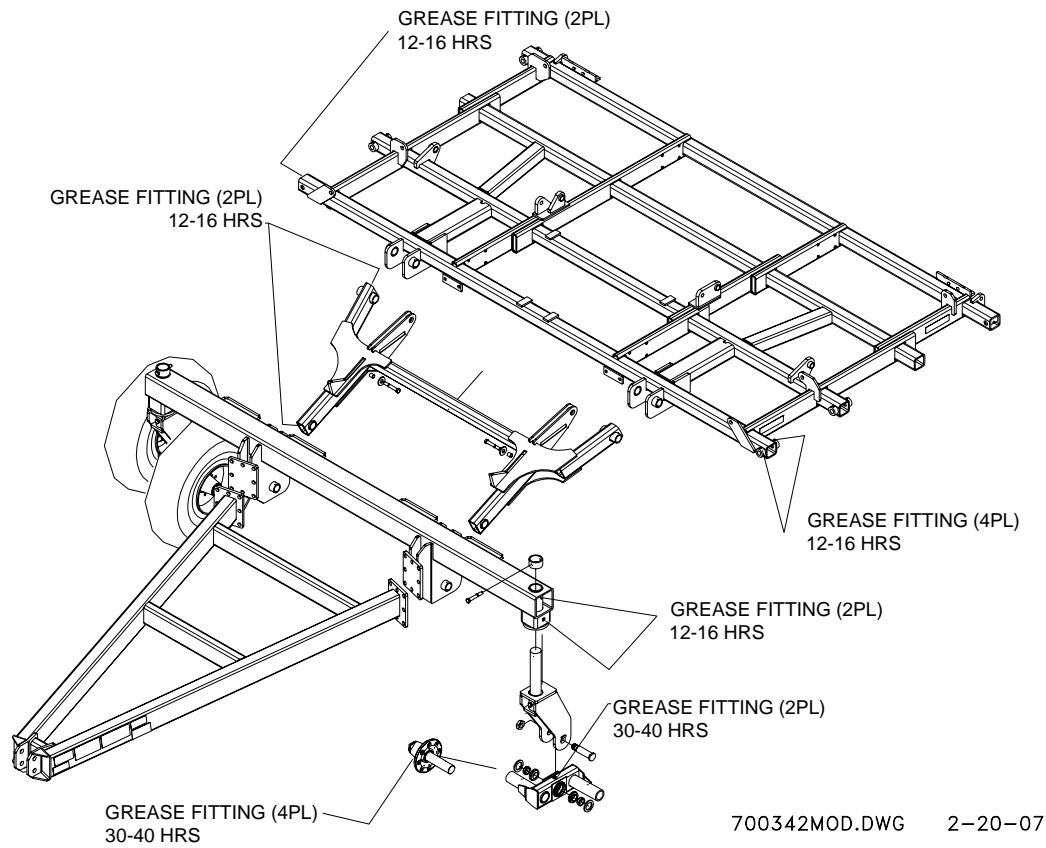

Check wheel hub and spindle nut and adjust to a moderate drag after the first 40 hrs of use. Recheck monthly thereafter. Repack bearings at end of season.

Check walker spindle nut and adjust to a heavy drag after the first 40 hrs of use and monthly thereafter.

700343MOD.DWG 2-20-07

DECAL LOCATIONS/GREASE FITTINGS - 40'/60'

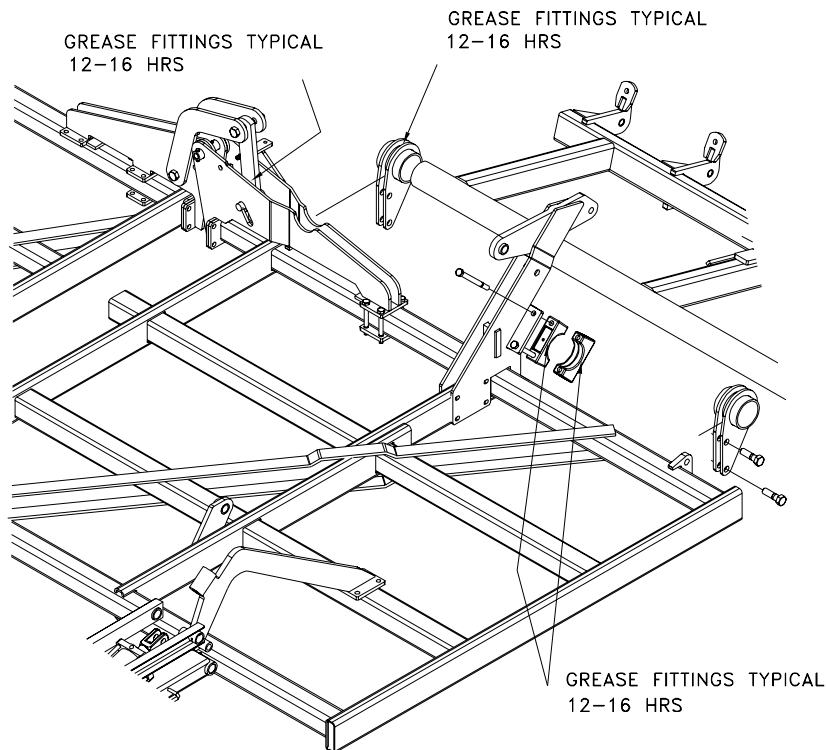
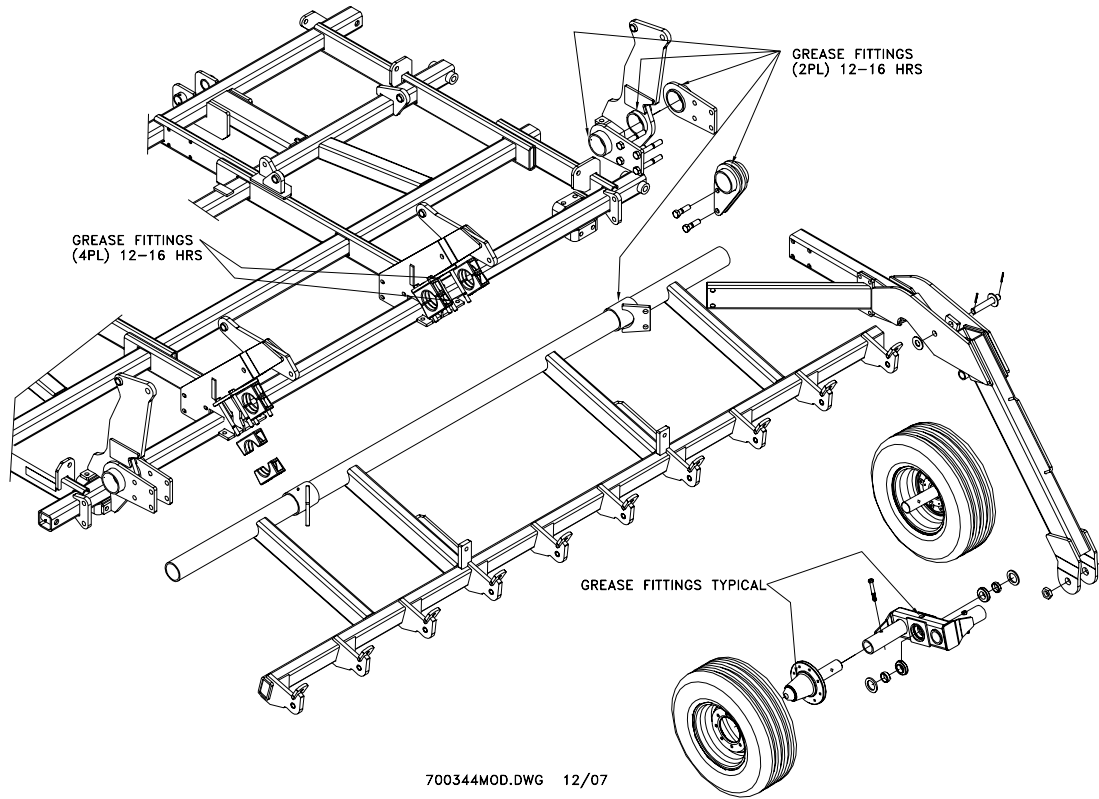

SAFETY LIGHTS MOUNTING

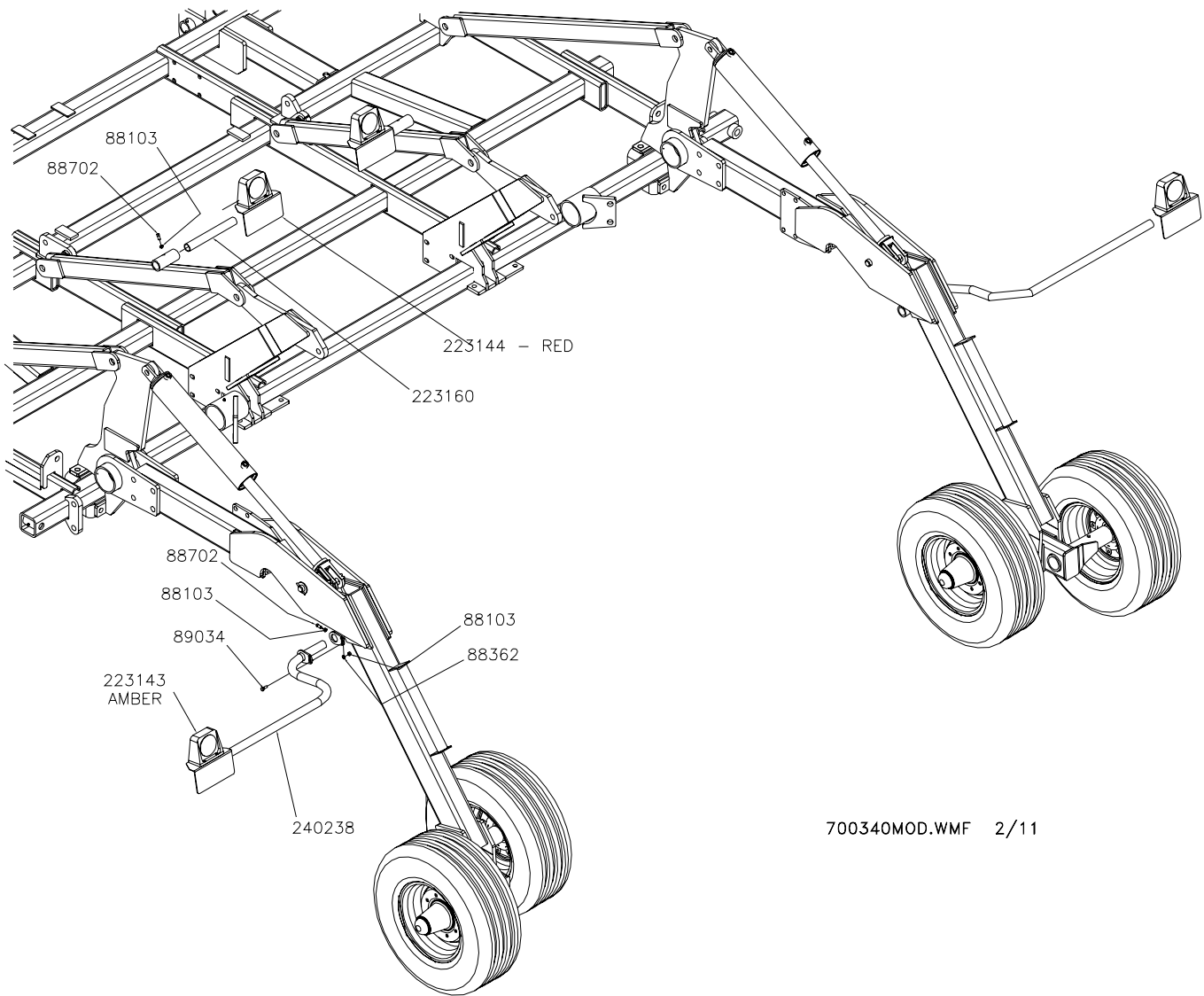

700340MOD.WMF 2/11

PART NO.	DESCRIPTION	QTY
223126	LIGHT/REFLECTOR BRACKET	4
223143	AG LIGHT, SINGLE AMBER TRI-PLUG	2
223144	AG LIGHT, SINGLE RED TRI-PLUG	2
223160	12 LIGHT ARM	2
240238	48IN OFFSET LIGHT ARM W/LOCK	2
88103	NUT HEX 3/8-16NC 5Z	12
88172	NUT HEX 1/4-20NC 5Z	16
88203	BLT HEX 1/4-20NCX1 5Z	16
88262	WSHR HLK 1/4ID(5/16ACT) Z	16
88362	WSHR HLK 3/8ID Z	2
88702	SCR SET 3/8NCX3/4 SQHD CUP-PT P	10
89034	BLT HEX 3/8NC X 1 5Z	2

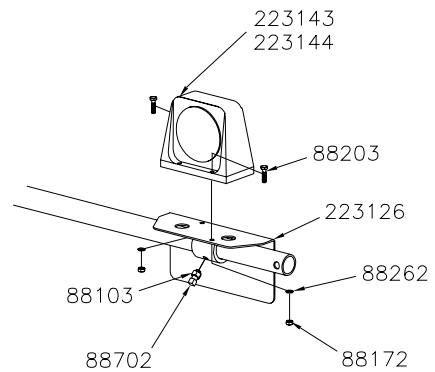

700340MOD1.WMF 2/11

SAFETY

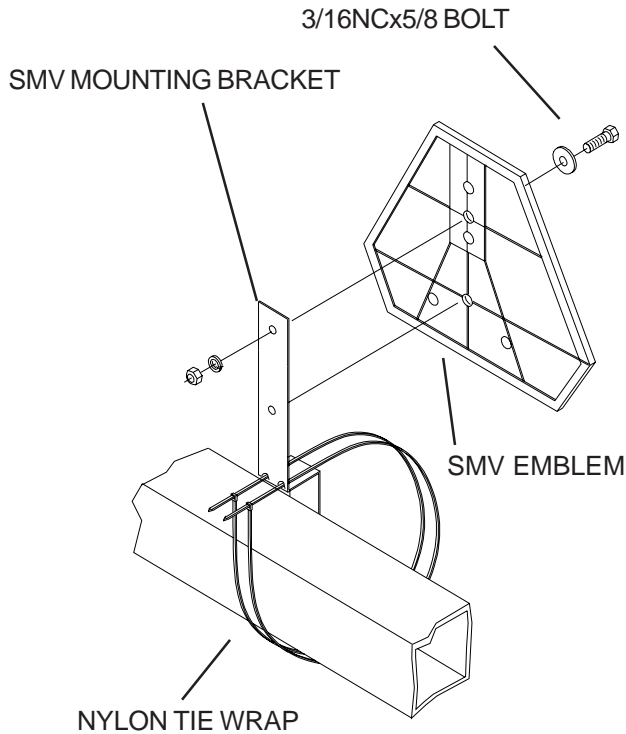

CI-77643

The bracket provided is designed to mount to numerous frame sizes and can be orientated in numerous positions to avoid interference with implement components.

The SMV emblem is to be secured as near to the rear and centered, or as near to the left of center of the implement as possible.

Emblem is to be 2 to 6 feet above the ground measured from the ground edge of the emblem.

Keep safety decals clean. Replace any safety decals that are damaged, destroyed, missing, painted over or can no longer be read. Replacement safety decals are available through your dealer.

SAFETY LIGHTS

NOTE: REFER TO LIGHT PLACEMENT INSTRUCTIONS SPECIFIC TO THIS UNIT. THIS SHOWS BASIC WIRE CONNECTIONS.

NOTE: MOUNT AMBER LIGHTS AS WIDE AS POSSIBLE. THE AMBER LIGHTS MUST BE MOUNTED NO MORE THAN 16" FROM THE IMPLEMENT EXTREMITIES.

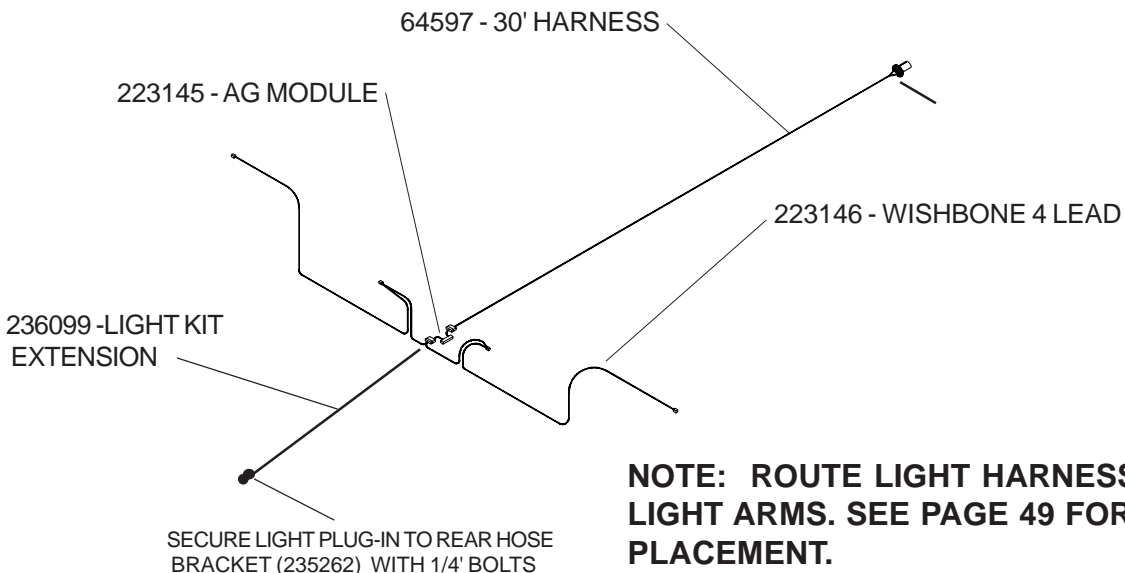

NOTE: ROUTE LIGHT HARNESS THRU LIGHT ARMS. SEE PAGE 49 FOR LIGHT PLACEMENT.