

Amity

TECHNOLOGY

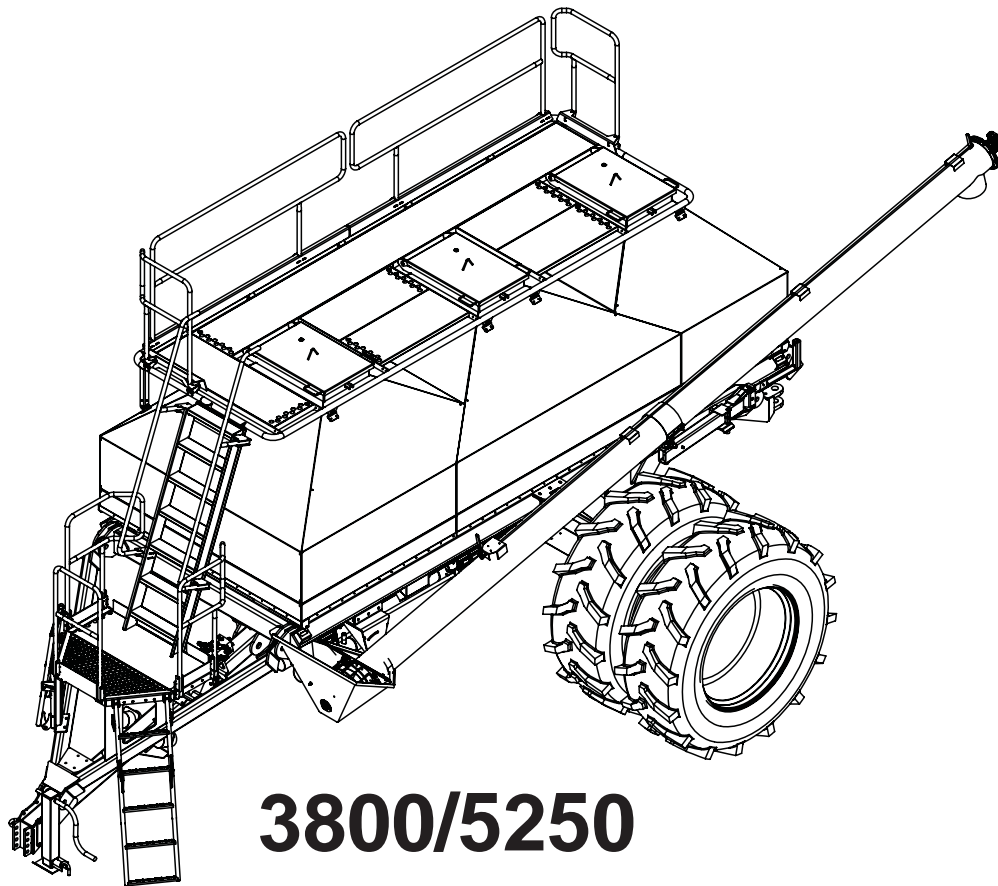

OWNERS OPERATING MANUAL



3800/5250 AIR CART

P/N 330544
S/N 702045, 702060...

Amity Technology, LLC
2800 7th Avenue North
Fargo, ND 58102
(701) 232-4199
www.amitytech.com

AMITY TECHNOLOGY, LLC LIMITED WARRANTY FOR NEW PRODUCTS

1. **General Provisions.** This Warranty shall apply to the original purchaser of (1) any new and unused machine manufactured by Amity Technology, LLC ("Amity"), and (2) any new and unused part which is manufactured by Amity for use in an Amity machine, jointly referred to as "Products," whether such Product is purchased through a dealer or directly from Amity. Under this Warranty, Amity will repair or replace, as it chooses in its sole discretion, any covered Product, or any component thereof, which Amity determines to be defective. This Warranty shall be in effect for a period of twelve (12) months ("the Warranty Period"), beginning on the date of delivery of the covered machine or part by the dealer or Amity to the purchaser ("the Warranty Start Date"). The purchaser must pay the cost of transportation of a Product to be repaired or replaced to and from an authorized Amity dealer. This Warranty may not be transferred from the original purchaser of a Product to any other person. This Warranty does not give a purchaser the right to any relief other than repair or replacement of the Product, and it specifically does not allow for consequential or incidental damages, exemplary or punitive damages, or costs and fees.
2. **Scope and Limitations of Warranty.** With respect to machines, this Warranty is void if any part not supplied by Amity is used in assembly or repair of the machine, or if the machine has been altered, abused or neglected, as determined by Amity. With respect to parts, this Warranty is void if the part is used in any manner other than that for which it is intended. This Warranty does not extend in any way to tires and any other component of a Product warranted by another manufacturer, a copy of which warranty is provided herewith ("Third-Party Warranties"). In the event Amity determines that a Product is not defective, or that any other provision of this Paragraph 2 operates to limit the Warranty, this Warranty shall not apply and the purchaser shall be responsible for transporting the Product from the authorized Amity dealer's location within 10 days of notice by Amity.
3. **Procedures for Obtaining Service.** To secure Warranty service, a purchaser must (1) report the defect to an authorized dealer and request repair within 45 days of the failure and within the Warranty Period; (2) present evidence that this Warranty applies to the Product; (3) present evidence of the Warranty Start Date; and (4) bring the Product to an authorized Amity dealer within a reasonable period of time after reporting the defect.
4. **LIMITATION OF IMPLIED WARRANTIES AND OTHER REMEDIES.** To the extent allowed by law, neither Amity, its dealers, nor any company affiliated with Amity makes any warranties, representations, or promises as to the quality, performance, or freedom from defect of any Product covered by this Warranty.
AMITY HEREBY WAIVES, TO THE EXTENT APPLICABLE, ANY AND ALL IMPLIED WARRANTIES OF MERCHANTABILITY AND FITNESS FOR A PARTICULAR PURPOSE. A PURCHASER'S ONLY REMEDIES IN CONNECTION WITH THIS WARRANTY ARE THOSE SET FORTH ON THIS PAGE. IN NO EVENT WILL AMITY, ITS DEALERS, OR ANY COMPANY AFFILIATED WITH AMITY BE LIABLE FOR INCIDENTAL, CONSEQUENTIAL OR PUNITIVE DAMAGES.
Some states do not allow waivers of certain warranties, so the above waivers may not apply to you. You may also have other rights which vary from state to state.
5. **No Dealer Warranty.** This is the exclusive warranty applicable to Amity Products. No dealer has any authority to make any other warranty, modify, limit, or expand the terms of this Warranty in any fashion, or make any representation or promise on behalf of Amity.
6. **Dispute Resolution.** Any controversy or claim arising out of or relating to this Warranty must be settled by arbitration in Fargo, North Dakota, at a time and location designated by the arbitrator, but not exceeding 30 days after a demand for arbitration has been made, and may be conducted by electronic, video, or other technical means. Arbitration will be conducted by the American Arbitration Association in accordance with its Rules of Commercial Arbitration, and judgment upon the award rendered by the arbitrator may be entered in any court having jurisdiction thereof. The arbitrator will have the authority to order Amity to undertake a repair or replace any Product, at its election, if the arbitrator finds that this Warranty requires Amity to do so. The arbitrator will not have the authority to impose any other remedy against Amity, including without limitation consequential or incidental damages, exemplary or punitive damages, or costs and fees.

• AMITY TECHNOLOGY, LLC • 2800 7TH AVENUE NORTH • FARGO, ND 58102 • e-mail address: info@amitytech.com •
(701) 232-4199 fax (701) 234-1716

Prices subject to change without notice

Table of Contents	
Congratulations!.....	6
Precautions.....	6
Safety First	
Features and Specifications.....	7
Air Cart	
Conversion Factors	
Formulas	
Mechanical Systems - Setup and Operation.....	8
Safety Railing / Ladder	
Product Bin Lids	
Auger	
Hdraulic Systems	
Hydraulic Drive	
Blower	
Tires and Rims	
D3 System Overview	15
D3 System Hardware	
Cart Control General Information	17
Using Virtual Terminals with Your Cart Control System	
Alarm and Indicator Icons	
Confirmation Screen	
Main (Home) Screen	
Fan RPM	
Product On/Off	
Desired Rate	
Actual (Live) Rate	
Product/Bin Alarms	
Bin Count	
Ground Speed	
Area Counters	
Seeder UP/Down	
Seeding State	
Work Switch Softkey	
System Set Up	24
System Settings Screen	
Units	
Cart Model	
Drive Type	

Fan Enable
NH3 Enable
Implement Width
Ground Speed Type
Test Speed
Fan Targets and High/Low Alarms
Work Switch Operation
Setting Up Work Switch Operation
Manual Work Switch Operation
Automatic Work Switch Operation
Dry Product/Bin Settings 28
System Settings Screen
Bin Size (Volume)
Bin Count %
Product Weight/Volume (Density or Test Weight)
Product Weight
Selecting Air Stream (Dual Chute Only)
Adjusting Product Meters
Hydraulic Drive Calibration and Operation
Mechanical Systems - Maintenance and Troubleshooting..... 41
Routine Maintenance
Changing Metering Rolls - Hydraulic drive System
Meter Roll Options
Other Meter Adjustments
Mechanical Systems Troubleshooting: Common Problems and Solutions
Storage
Appendix: Connector Pinouts..... 46
ECU Signal Conectors
ISO-BUS Connector
CAN Terminator Connector
ECU Power Contacts
Motor Control Connectors
Low-Bin Level Sensor Connectors
Motor Speed (Tach) Connectors
Meter Box Sensor Connectors
Ground Speed Sensor Connectors
Fan Sensor Connectors
Anhydrous Ammonia/Liquid Control Connector
Approximate Tank Fill Percentages
Advanced Screens
Sensor Types

CONGRATULATIONS!

Congratulations on your purchase of an Amity Technology Air Cart! Your Model 5250 Air Cart has been designed to be durable, versatile, and simple to use.

Your Air Cart features stainless steel tanks and metering components, a streamlined and reliable meter system, a fill/unload auger with cupped poly lighting, and a world class ISOBUS-compatible monitoring and control system.

The following pages contain a wealth of important information on your Air Cart's features, equipment and systems. Read this manual carefully to learn how to set up, operate and use this equipment.

PRECAUTIONS

Safety First

The purpose of this manual is to assist you in safely operating and maintaining your Amity Technology equipment. It is the responsibility of the owner to ensure that anyone operating this equipment thoroughly reads and understands the information in this document.

It is not possible to overstate the importance of safety. Serious injury or death can result from improper operation of any farm equipment. We have taken great care to point out potential hazards that require special consideration.

Warning and Caution Symbols



This manual uses the following symbols to signify caution and warning. For your own safety take note of these symbols and exercise caution when working with this equipment.



Warnings

***ALWAYS** know your equipment. Read the owners manual before operating.*

***DO NOT** allow anyone to ride on the Air Cart.*

***ALWAYS** install and transport stops when transporting the drill.*

***ALWAYS** use an adequate tow vehicle.*



***ALWAYS** remember to properly secure the safety chain.*

***DO NOT** Transport at speed greater than 20 MPH (32 KmPH).*

***DO NOT** modify or alter this equipment without first contacting Amity Technology, LLC.*

Caution

***ALWAYS** keep decals free of dirt and replace if they become damaged. See the parts section for proper placement.*



***ALWAYS** avoid high-pressure fluids. Use a piece of cardboard to search for suspected hydraulic leaks.*

FEATURES AND SPECIFICATIONS

Air Cart

Feature	AS3800	AS5250
Hopper Capacity	380 Bu(128 front, 158 center, 94 rear)	525 Bu (175 front, 225 center, 125 rear)
Blower Drive	Hydraulic Drive	Hydraulic Drive
Meter Drive	Hydraulic Drive	Hydraulic Drive
Wheel Spacing	142" OC	Inside Duals 118" OC Outside Duals 182" OC
Tire Size	80070R38 Singles	620/70R42 Duals
Fill/Unload Auger Cupped steel flighting (poly flighting optional)	10" x 25' (25.4 cm x 7.6 m)	10" x 25' (25.4 cm x 7.6 m)
Total height	14' 0" (4.26m)	15' 4" (4.67 m)
Total length	29'1" (6.94m)	29' 4" (8.94 m)
Max width	17' 6" (5.33 m)	17' 6" (5.33 m)
Fill height	10' 10" (3.07 m)	12' 2" (3.71 m)
Minimum ground clearance	18" (45.72 cm)	18" (45.72 cm)
Empty weight	13,500 lbs (6124 kg)	15,750 lbs (7144 kg)

Conversion Factors

1 Hectare = 2.47 Acres	1 lb = 0.45359 kg	1 bushel = 1.2445 cubic ft
1 acre = 43,560 square feet	1 lb = 16 oz	1 bushel = 0.0352 cubic meters
1 acre = .404 Hectares	1 kg = 35.3 oz	1 bushel = 9.31 gallons
1 inch = 2.54 cm	1 oz = 0.028 kg	1 PSI = 6.8948 kPa
1 foot = 0.3048 m	1 mph = 1.609 kph	1 GPM = 3.785 LPM
	1 mile = 1.609347 km	

Formulas

$$\text{Rate (lbs/min)} = \frac{\text{Width (ft)} * \text{Speed (mph)} * \text{Field Rate (lbs/acre)}}{495}$$

$$\text{Performance (acres/hr)} = \frac{\text{Width (ft)} * \text{Speed (mph)}}{8.25}$$

MECHANICAL SYSTEMS - SETUP AND OPERATION

Safety Railing / Ladder

Your Air Cart is equipped with a ladder and safety railings for access to the top of the tanks. Always make sure that the safety railings are secured in the raised position when operating the air cart. The railings may be lowered for storage if required.

To lower the railings, remove spring pins and fold down the side railings over the top of the tank, then proceed to fold down the front and rear hand rails over the side rails. Reinsert the spring pins for storage.



Caution

Do not lower the railings while standing on the catwalks. Use a suitable ladder and lower them from below. Always have the railings raised when working on top of the air cart.



Safety railings

Product Bin Lids

The compartment lids on the air cart compartments must be properly closed and sealed for the meters to deliver product properly.

Periodically check the lid for proper adjustment and inspect the seal for damage.

To determine whether the lid is adjusted properly, observe the lid when it is unlatched. It should incline slightly toward the latch end. A firm pull on the latch handle should be required to over-center the latch.

To adjust the hinge end of the lid, loosen or tighten the jam nuts on the hold down bar. (See photo)

To adjust the latch, loosen or tighten the nuts on the toggle u-bolt. (See photo)

In the off season, it is recommended that the latch be released to relieve pressure on the gasket.



Caution

If equipped with screen baskets, do not step or lean on the screens. They will not support a person's weight and may fall into the tank, resulting in injury.



Lid and latch with toggle u-bolt adjustment



Jam nuts on hold-down bar

Auger

Your Air Cart is equipped with an auger for loading and unloading the product bins. The auger is mounted on a swing arm that allows a flexible discharge hose to be moved to each compartment without moving the hopper. The swing arm also enables the auger to be turned around to unload and clean out the compartments.

The auger's hydraulic drive is supplied with oil from the blower hydraulics. A diverter valve in front of the machine directs oil to the auger. This may be switched with the blower running.

The auger also has a three position variable speed valve mounted on it to run the auger forward, backward or to stop.

A diverter valve in front of the machine selects either the fan or auxiliary (auger and/or winch) function. Push the knob in to run the blower. Pull the knob out to run the auger or winch.

Using the Auger to Load Products

The auger can be used to load and unload the seed tanks. Use the diagram on the right to help in locating the auger arms to the correct position. **Always find a level area to fill the cart, if not, arms may be difficult to move.**

To place the auger in operating position:

1. Drop the lock pin into the neutral position.
2. Pull down the spring loaded pin on the inner arm and the outer arm into the detent position.
3. Remove the Auger from the clamp and pull the inner arm into position by swinging the hopper away from the Air Cart.
4. Once the inner arm is in position to fill the desired bin, release the detent pin on the inner arm and lock into place. Pull down the outer arm pin so the auger is free to move from the inner arm.
5. Position the auger over the lid of the tank which you would like to fill.

Tip

Place the hopper on the ground in a position perpendicular to the center tank lid. From this position the discharge end of the auger should be able to be moved between compartments without moving the hopper.

Note

When moving to a different compartment, remember to return the spring loaded pin into the detent position or damage may occur.

A diverter valve in front of the cart selects fan or auxiliary (auger and/or winch) function. Push the knob in to run the blower. Pull the knob out to run the auger or winch.

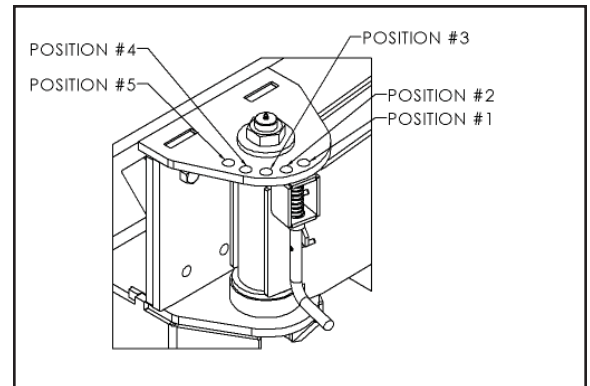

PIN LOCATION REFERENCE			
	BIN #1	BIN #2	BIN #3
POSITION #1	STOWED	STOWED	STOWED
POSITION #2	UNUSED	UNUSED	LOAD
POSITION #3	UNLOAD	LOAD	UNLOAD
POSITION #4	LOAD	LOAD	LOAD
POSITION #5	UNUSED	UNUSED	UNUSED

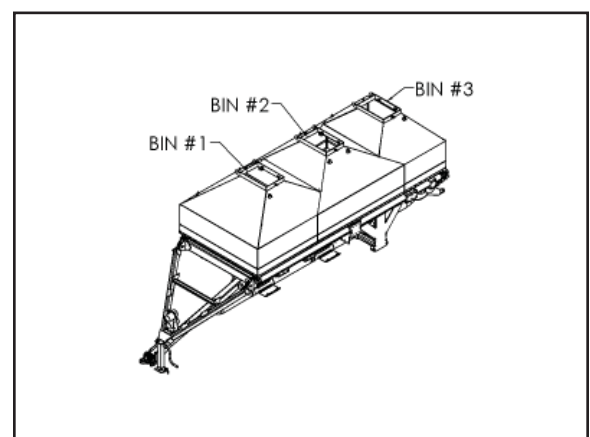
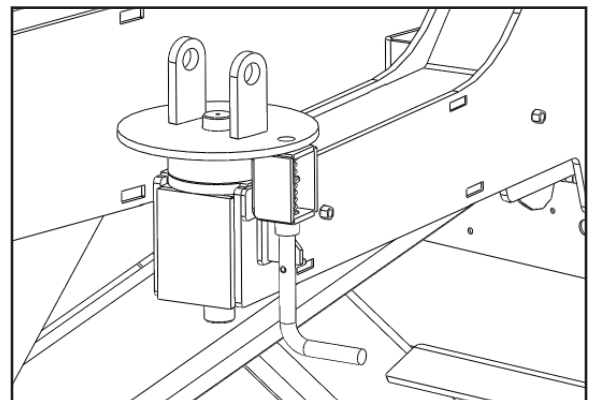

Using the Auger to Unload Products

1. Swing the inner arm far enough away from the machine to allow the hopper to fit in front of the wheels. See diagram for inner arm position.
2. Place the hopper under the meter for the compartment you wish to empty.

Tip

For the rear tank, the outer arm will have to swing greater than 180 degrees in order to achieve this.

3. Close the metering slide.
4. Remove the product meter door.
5. Open the metering slide to control flow from the compartment.

Note

Removing the pointer allows the gate to be opened without changing the rate setting.



Placing the hopper under the meter



The meter with door removed

Cleaning Out the Auger

1. Tip the hopper upside down to empty.
2. Run the auger backwards until the auger tube is empty.



Hopper in the upright position

Hydraulic Systems

The hydraulic system on 5250 air carts consists of a blower control circuit, an auger control circuit, and a hydraulic meter drive control circuit. A combination of various control valves enables all three circuits to be powered by one hydraulic remote on the tractor. This system was designed to function under a maximum hydraulic pressure of 2900 psi.

Hydraulic Capacity

<i>Fan w/ Hyd Drive</i>	<i>10cc Fan Motor w/5 gal meter priority</i>	
Fan Speed (rpm)	Flow (gpm)	Pressure (psi)
3000	13	1200-1700
4000	16	1600-2100
5000	18.5	2000-2500
6000	21	2400-2900

<i>Fan Only</i>	<i>10cc Fan Motor</i>	
Fan Speed (rpm)	Flow (gpm)	Pressure (psi)
3000	8	1000-1500
4000	10.5	1400-1900
5000	13.5	1800-2300
6000	16	2200-2700

Air Cart to Drill Hydraulic Couplers (tow behind cart)

The couplers connecting the air cart to the drill/implement are (3/4") #12 ISO 7241 Series B, high-flow couplers. Using these reduces the pressure drop across the coupler and enables the operator to easily disconnect the air cart from the drill/implement. It is important to ensure that the pressure line on the tank is connected to the pressure line on the drill.

The blower motor case drain line employs a (5/8") #10 ISO 7241 Series B coupler. This smaller size ensures that it cannot be confused with the larger couplers.



Caution

Be sure that the case drain line on the blower motor is not connected to pressure. Damage to the shaft seal or motor will result.



Hydraulic Couplers

Air Cart to Tractor Hydraulic Couplers (tow between cart)

The couplers connecting the air cart to the tractor are (1/2") #10 ISO 5675 (Pioneer) tip couplers connect the blower pressure and return lines to the tractor.

A (3/8") #8 ISO 16028 (flat-face) coupler tip on the drill connects the case drain line to the tractor. This line must be connected or the blower motor will be damaged. If a case drain return port is not available on your tractor, contact your dealer for assistance in determining how to connect this line to the tractor's hydraulic reservoir.

A (3/4") #12 ISO 7241-1 Series A low-pressure return tip is included with all Amity implements. It is also available through Amity Service Parts P/N (69120). If your tractor has a low-pressure port available, this tip can be used on the 3/4 inch blower return line to eliminate the pressure drop caused by the 1/2 inch Pioneer tip and the tractor's hydraulic valve on the return side. This tip can also be used on the case drain line, if the 3/8 inch flat face port is not available and the 3/4 inch low pressure return port is.

Do not install a tee connecting the blower return line and the blower case drain lines together. The blower case line must always be connected to a direct return to the hydraulic reservoir or blower motor failure will result.

The hydraulic line marked Pressure must be used to operate the blower. A check valve is installed in the blower circuit to protect the motor from an accidental pressurization of the return line and prevents cavitation during shutdown.

Note

The 3/4 inch low pressure return tip is not compatible with the 3/4 inch high flow fittings used at the front of the cart. They look similar, but they are not compatible.

Hydraulic Drive

This air cart is equipped with the hydraulic drive option that uses electric-over-hydraulic (EOH) technology to control the meter speed independently of ground speed. This gives the operator the benefit of a faster calibration procedure and on-the-go rate changing capability as well as the potential to apply product to a prescription map using GPS.

The hydraulic drive control valve diverts 5 GPM of hydraulic fluid flow from the right hand fan circuit to power the hydraulic drive motors. An electro-proportional flow-control valve controls the speed of each motor, allowing the meters to turn at speeds completely independent of each other.



Tractor Hydraulic Connections (1)



Tractor Hydraulic Connections (2)



Hydraulic drive Control Valve

The hydraulic drive motors mount to the meter housing and provide a direct drive of the meter shaft. The motor has a built-in speed sensor to provide accurate meter speed feedback to the electronics system.



Hydraulic drive Meter Drive Motor

Blower

The air cart's blower system generates air pressure/flow to carry the seed or other input products through the system to the implement. The blower is driven by a hydraulic motor and two $\frac{3}{4}$ " hydraulic lines supply oil to the blower.

The only serviceable part on the blower is the shaft seal. This may be replaced if the motor leaks at the shaft. Do not disassemble the motor to replace the shaft seal. It is secured by a snap ring and can be removed with a seal pick.



The blower and associated hydraulics



Caution

Be sure that the case drain line on the blower motor is not connected to pressure. Damage to the shaft seal or motor will result.



Warning

Do not under any circumstances disassemble the motor. It is very difficult to assemble correctly and motor destruction will result from running an incorrectly assembled motor.

Setting Blower Speed

The blower should be operated at as slow a speed as possible to prevent damage to seed. If operated too slowly, line blockage will occur. Typical blower speeds are between 3000 and 6000 RPM. Drill width, product, rate, humidity and other factors affect blower speed.

If you do not have a run blockage monitor, carefully watch to see that all runs are operating after changing blower speeds. To check runs, turn meter(s) with blower running and look to see that there is product at each ground opener.

Tip

If high rates are being applied with this implement and it is equipped with two fans, use the fan only circuit with the low pressure return fitting, if applicable. This will help alleviate the backpressure in the circuit and give the maximum output.

Note

The number of outlets on the drill will directly affect the blower rpm. The more outlets in use, the higher the pressure required to maintain blower rpm. See your dealer for hydraulic adjustments to your tractor, if necessary.



Note

A diverter valve (2) in front of the cart selects fan or auxiliary (auger and/or winch) function. Push the knob in to run the blower. Pull the knob out to run the auger or winch.



Warning!

Warning

Do not under any circumstances disassemble the motor. It is very difficult to assemble correctly and motor destruction will result from running an incorrectly assembled motor.

Tires and Rims

Inflate tires to the pressure indicated in the adjacent table. Torque lug nuts to 500 ft/lbs oiled and retighten after the first 10 hours of operation.



Caution!

Caution!

Maximum speed of the air cart is 20 mph.



Caution!

CAUTION!



Caution!

TIRE PRESSURES

Tire Size	Load Index	Tire Pressure
620/70R42	166 A8	15 psi loaded field 30 psi loaded road

D3 SYSTEM OVERVIEW

Your Air Cart utilizes a state-of-the-art electronic system to monitor and control the air cart's functions. The D3 ISO Monitor system is based on the ISO 11783 standard, often also referred to as ISOBUS. ISOBUS is a communications standard that enables a variety of agricultural electronics systems to talk to each other. Its purpose is to integrate all current and future farm functions by standardizing communication between tractor and implement. ISOBUS permits the use of the same tractor terminal on a number of different machines and hence control of a wide range of implements without the need to reprogram a system.

D3 System Hardware

The D3 ISO System includes a D3 electronic control unit (ECU), which connects to a variety of sensors and an electric-over-hydraulic (EOH) meter drive system. The ECU communicates with a virtual terminal (VT) located inside the tractor cab. The VT displays information and enables you to configure, calibrate and operate multiple systems from a single user interface.

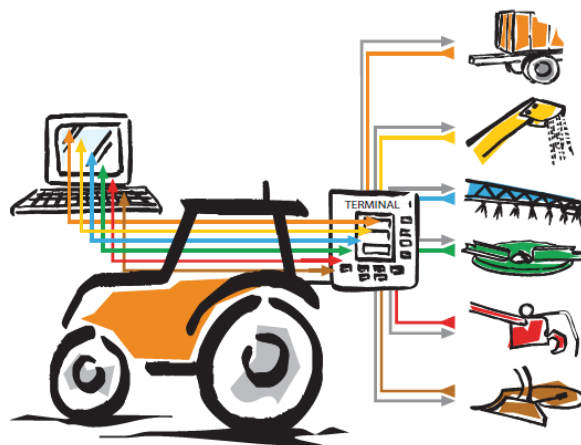

D3 Electronic Control Unit

The ECU is mounted on the air cart. It monitors all system sensors and controls the meter drives. The ECU connects to the VT in the tractor cab via an interconnecting cable that plugs into the front of the ECU on one end and into the standard ISOBUS connector on the tractor at the other end.



D3 ECU

Virtual Terminal

The VT in the tractor cab provides a user interface for the system, communicating with the D3 ECU and (any other ISOBUS-compatible equipment you may add to your equipment). Your VT could be the Amity-supplied VT, the tractor's OEM VT, or any other ISOBUS-compatible VT.

Several companies manufacture ISOBUS-compatible virtual terminals. All terminals use the same screen icons to represent the main functions. The control screens, or pages, for the implement (which are displayed in the central area of the screen) are identical for any ISOBUS-compatible terminal.

Currently the following virtual terminals can be used with your ISO Drill Manager system:

- GTA Console 1 and Console 2 (AGCO)
- AFS Pro 600 & Pro 700 (Case IH)
- GreenStar2 & GreenStar3 (John Deere)
- IntelliView II IntelliView Plus II (New Holland)
- IntelliAg (DICKEY-john)
- LH6000 (TeeJet)



C1000



C2000

Blower Speed Sensor

An inductive sensor on the blower fan provides speed information to the ECU.



Bin Level Sensor

Optical bin sensors indicate when the level of product in the bin has decreased to the level of the sensor. The same sensor detects all types of products. The sensor height can be adjusted vertically to set the alarm point at any desired level.



Meter Box Flow Sensor

A capacitive sensor detects when the meter box is empty. This indicates if the bin is completely empty, or if the product has stopped flowing into the meter box because of bridging or a leaky lid on the bin.



Meter Shaft Speed Sensor (Hydraulic drive)

If the air cart was purchased with the hydraulic drive option, an integral speed sensor is provided with the hydraulic motor. This sensor is very accurate and provides the precise meter speed control that is needed.



Ground Speed Sensor

This unit is equipped with a GPS speed sensor. This is used for speed sensing only and cannot be used for mapping.

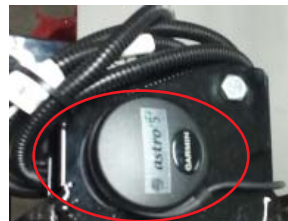

CART CONTROL GENERAL INFORMATION

Using Virtual Terminals with Your Cart Control System

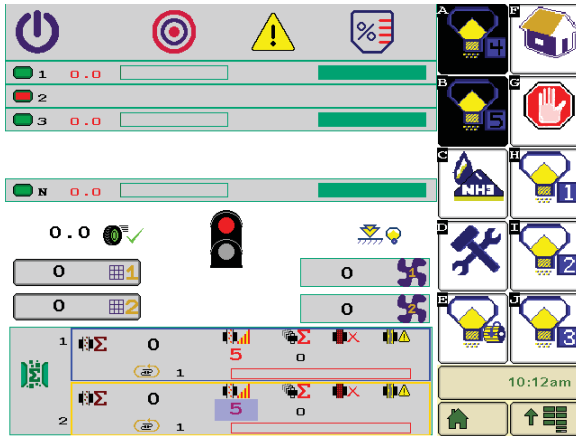

An example of an ISO Monitor page

Any ISOBUS-compatible virtual terminal (VT) should be able to communicate with and control your Cart Control System. When the VT in your tractor is connected to the ECU on the cart it downloads the information from the ECU and displays it on the VT's screen. The central part of the screen displays information pages identically, regardless of the VT you are using. Typically, icons representing other pages are located around, or to the side of the central part of the screen. Selecting these soft keys enables you to navigate to the pages they represent. The location of page icons may vary depending on the manufacturer of the VT. Also, some VTs have touch screens, whereas others use pushbuttons located around the outside of the screen, adjacent to on-screen icons.

ISOBUS compatible VTs can be used to set up, operate and monitor your Cart Control System but the exact details of how to access and change values and settings may vary from manufacturer to manufacturer. You will have to consult the manufacturer's operating manual for your specific VT to determine the details.

Tip!







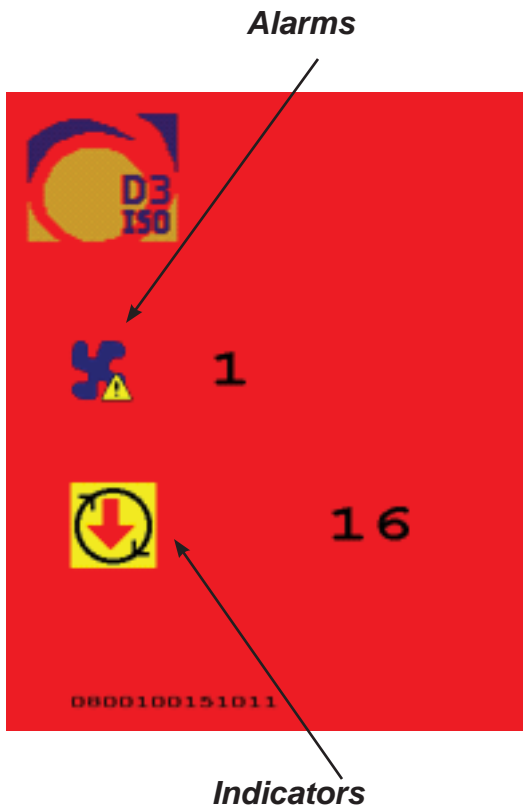

For detailed information on how to operate your virtual terminal, refer to its operation manual.

Alarm and Indicator Icons

The following is a list of alarms and Indicator that could occur during system operation. Alarms show up as separate screens and are acknowledged based on your Virtual Terminal type.



Icon	Alarm
	Product Rate Alarms
	Bin Alarms
	Fan Alarms
	Meter Box Alarms
	NH3 Alarms
	Blockage Alarms
	Low Ground Speed Alarm
	Battery Voltage Alarm
	Internal Alarm
Icon	Indicator
	High RPM Indicator
	Low RPM Indicator
	Empty Indicator

Icon	Indicator
	High Voltage Indicator
	Low Voltage Indicator
	Current Overload Indicator
	No Tachometer Indicator
	SPI Communication Failure Indicator
	Low Seed Rate Indicator
	Blocked Seed Run Indicator
	Loop Communications Failure Indicator

Low RPM Indicator

Note:



- This alarm screen shows Fan 1 in alarm with a RPM of 16.

- Acknowledging the alarm is done by either touching the "OK" softkey or the "ESC" button. This will vary based on which virtual terminal you are using.



Confirmation Screen

Changing of certain settings or values on your Amity Cart Control System may require confirmation, clearing an acre counter for example. When confirmation is needed, a confirmation screen will appear.

- To Confirm your selection and return to the previous screen, select the  softkey.
- To Cancel your selection and return to the previous screen, select the  softkey.

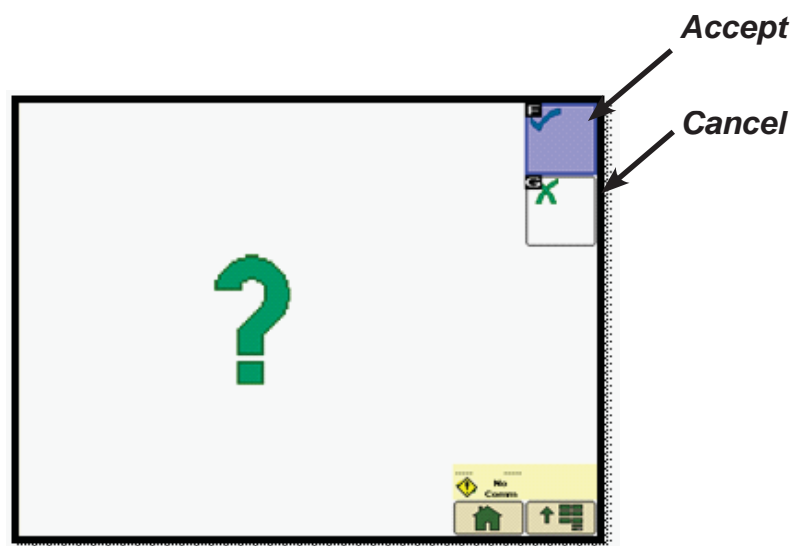

Main (Home) Screen

On the Main page of the Cart Control System you can view many critical machine functions. The following screen shot shows the key information provided on this page. Each function will be explained in greater detail following this diagram.

Seeder up/down

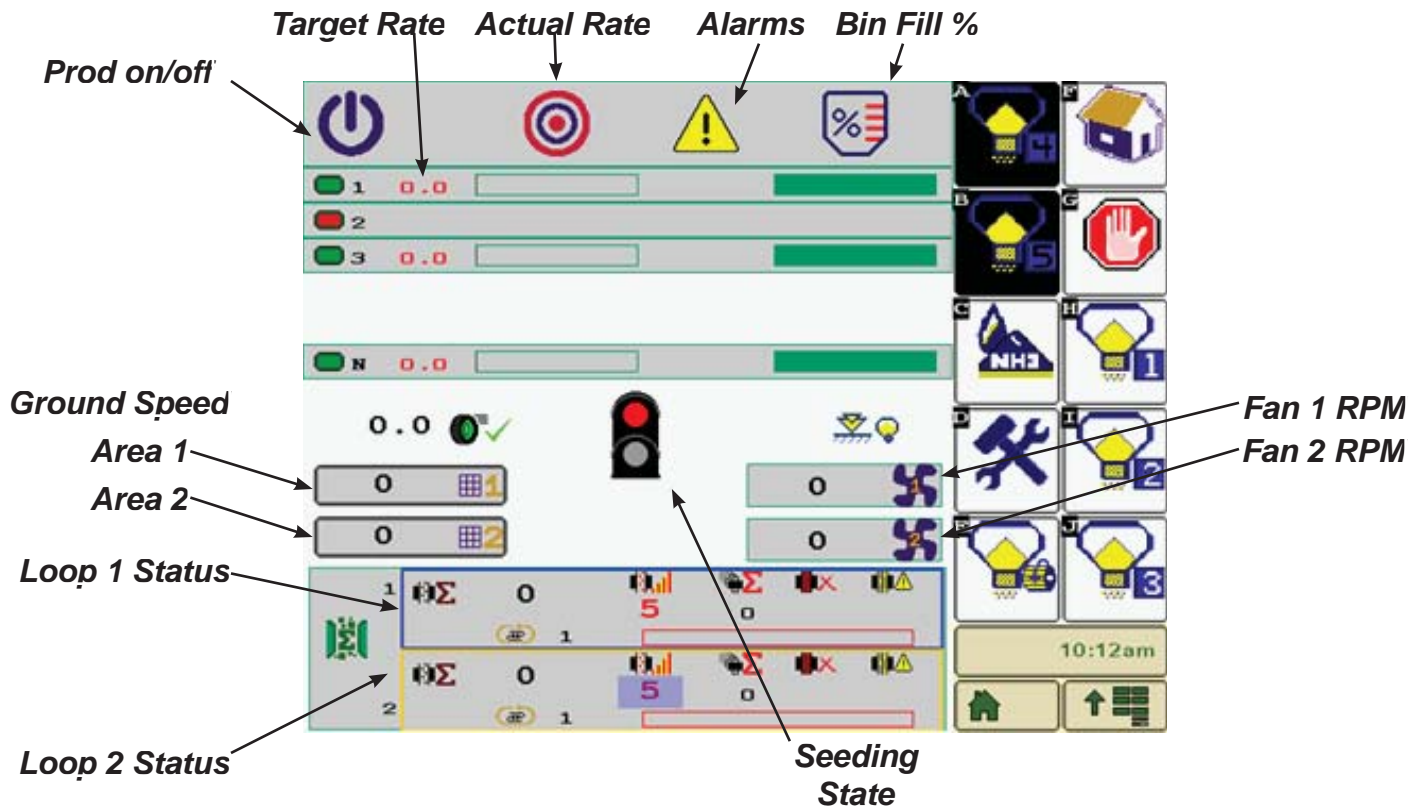

Home Screen Softkeys			
Icon	Page	Icon	Page
	Main (Home)		On/Off (Manual Work Switch)
	System Settings		Product Bins Settings (1-5)
	NH3 Settings		Meter Fill

Note: If the softkey is blacked out, it means either the feature is turned off or the feature is setup to be used with an External ECU (Blockage or NH3 for example).

Fan RPM

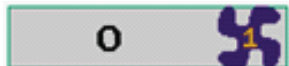

Displays Fan speed in RPM. Min and Max alarms can be set in the **System Settings** screen. See System Setup for more information.

Product On/Off



Pressing the **Product On/Off** buttons will turn any particular product on or off. A **Green** indicator represents **Product On** and a **Red** indicator represents **Product Off**.

The single clutch on Ground Drive units is tied to Product 1, individual bin control is not available.

Desired Rate



The Desired rate for each product is entered by modifying the **Red** value next to Product On/Off. Desired Rate displays lb/acre (kg/ha).

Note: Desired Rate is for reference only on ground drive units.

Actual (Live) Rate



Graphically displays the Actual Rate for Motors 1-5 and N (liquid NH3) as a percentage (0-200% of desired rate). When the indicator bar is in the center of the graph, the Actual Rate matches the Desired Rate. The Desired rate for each product is also numerically shown in **red**.

Product/Bin Alarms



The following symbols can be displayed in the alarm box for each product/bin.

Symbol	Alarm
	Bin Low Alarm
	Meter Box Low Alarm
	Drive Manual Mode
	Rate High Alarm
	Rate Low Alarm
	Motor Overload Alarm
	No Tachometer Alarm
	No Slave ECU
	Calibration Active

Bin Count



Displays the status of the bin levels as a percentage. The Bin Count feature can be calibrated in the **Product Calibration** screen. These indicators are an approximation based on the calculated meter accumulation and must be properly calibrated in order to properly function.

Ground Speed



Displays Fan speed in RPM. Min and Max alarms can be set in the **System Settings** screen. See System Setup for more information.

Area Counters



Displays total area in **Acres** or **Hectares**. Pressing the **Area** button will clear the area accumulation.

Seeder UP/Down



Displays the current up or down state of the seeder. If there is a work switch on the seeder, the **Seeder Up/Down** indicator will change as the seeder is lifted up or set down. If there is no work switch present on the seeder, the **Seeder Up/Down** indicator will always reflect the down position.

Seeding State



Displays whether the seeder is seeding or not. A **green** indicator will show when the drill is in the seeding state. Seeding can only occur if the **Seeder Up/Down** indicator is in the down position, the work switch softkey is **green**, and speed is present.

Work Switch Softkey



Pressing the **Work Switch Softkey** will turn the seeder on if there is no automatic work switch installed on the seeder. If there is an automatic work switch installed on the seeder, pressing the **Work Switch Softkey** will enable operation of the automatic work switch.

SYSTEM SET UP

Important!

This system setup procedure **MUST** be completed or your system will not operate correctly. Complete all steps.

Before operation of your new Amity Cart Control System, there are a few simple setup and calibration procedures that must be performed to ensure proper seeding performance. If these operations are not completed, seeding performance and accuracy will be affected.

System Settings Screen

Use the following procedures to set up system parameters before using your system:

Cart Model 280 335 380 525

Drive Type

Fan Enable 1 2

NH3 Enable

Implement Width 480 394

External ECU Setting TCAN ART TCAN NH3

Software Version v03.0z

Ground Speed Type

Fan Settings

Units Indicator
 U - U.S.
 M - Metric
 I - Imperial
 ? - Mixed

System Setup Screen Softkeys			
Icon	Page	Icon	Page
	Main (Home)		On/Off (manual work switch)
	Advanced Settings		Sensor Channels
	Advanced Settings Lock		

Units



The Amity Cart Control System utilizes either SAE (US) or Metric units. Units are configured in the Virtual Terminal System Settings. Verify which system of units your VT is using before entering these values and operating your system. Refer to your VT Operators Manual for more information on checking the units. The **Units Indicator** on the **System Setup Screen** displays the units setting of the Virtual Terminal for your reference.

Cart Model



The Cart Model is a preset factory selection. It sets all necessary advanced settings for the defined cart.

Drive Type



The Drive Type is a preset factory selection. It sets all necessary advanced settings for the defined drive type. The first selection is for ground drive, the second is for hydraulic drive.

Fan Enable



Fan Enable selection is defined by the user. Selection is either **Green On** or **Gray Off**. Fan Enable allows for the display of fan rpm and fan alarms.

NH3 Enable



NH3 Enable selection is defined by the user. Selection is either **Green On** or **Gray Off**. NH3 Enable allows for NH3 application.

Implement Width

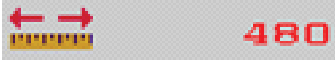

Tip!

If your machine is 60 feet wide, multiply 60 X 12 inches per foot = 720 inches. Enter "720".





Step 1. On the System Setup page, select **Width** by pressing the number next to the width icon. 

Step 2. Enter the width value in **inches** or **millimeters**.

Ground Speed Type



Pressing the Speed Button will toggle between the different ground speed input types. The ISO speeds are only available if the tractor is broadcasting these over the ISO-BUS.

Symbol	Speed Type
	Cart Speed (Default for Normal Operation)
	Test Speed (Set in the Calibration Menu)
	ISO Ground Speed (Tractor GPS)
	ISO Wheel Speed (Tractor Wheel or Radar)

Test Speed

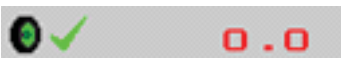

Note:

Speed Type must be set to Test Speed to take effect



Step 1. Select the number next to the **Test Speed icon** 

Step 2. Enter the desired test speed in **mph** or **kph**.

A test speed will affect both dry products and NH3 operation.

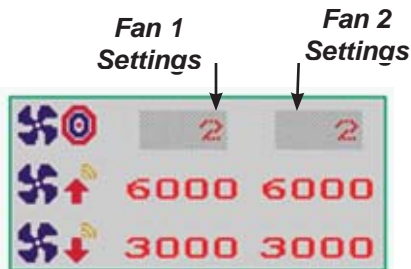
Fan Targets and High/Low Alarms



Fan target settings  as well as fan high and low alarm  /  settings are shown here. The fan high and low alarm values are editable and can be changed based on user preference.

Work Switch Operation



The Cart Control System is equipped with manual and automatic work switches. The manual work switch is a soft key, located on most screens. The automatic work switch is a sensor, located on toolbar. When the system is configured for automatic work switch operation, lifting the machine automatically turns off the meters and NH3 system. Lowering the machine automatically turns on the meters and NH3 system. In this mode you can also use the manual work switch soft key on the main (Home) screen to turn the meters and NH3 system off. If you prefer to operate the meters and NH3 system in manual only, you can configure the system to disable the automatic work switch.

Setting Up Work Switch Operation

Selection of manual or automatic work switch is located on the Toolbar ECU Main (Home) page.  Select the work switch button to switch between work switch modes.

Green indicates Automatic Work Switch mode



Gray indicates Manual Work Switch mode (Automatic mode off)



Manual Work Switch Operation

The On/Off (Work switch) soft key  turns products on or off.

Automatic Work Switch Operation

Note:

The following conditions must be met for the clutch to engage or for the hydraulic motors to turn:

-Ground Speed must be above the minimum speed setting.

-The Work Switch Softkey must be green

-The Seeder Up/Down must show "Seeder Down".

Tip!

You can still use the On/Off (Work switch) soft key on the main (Home) page to turn the machine off in automatic mode.

Use the following procedure to set up **Automatic** Work Switch operation:

Step 1. Raise the seeding system.

Step 2. On the Main (Home) page, press the On/Off (Work switch) soft key. 

Step 3. Start moving forward in the field with the tractor and planting system.

Step 4. Lower the seeding system. The **Seeder Up/Down** display should indicate **Down**.



The Seeding State display should turn green. 

DRY PRODUCT/BIN SETTINGS



Each product has its own screen to set up and monitor application rates.

•Numbers in **RED** are input numbers that can be modified.

•Numbers in **BLACK** are displayed output numbers that cannot be modified.

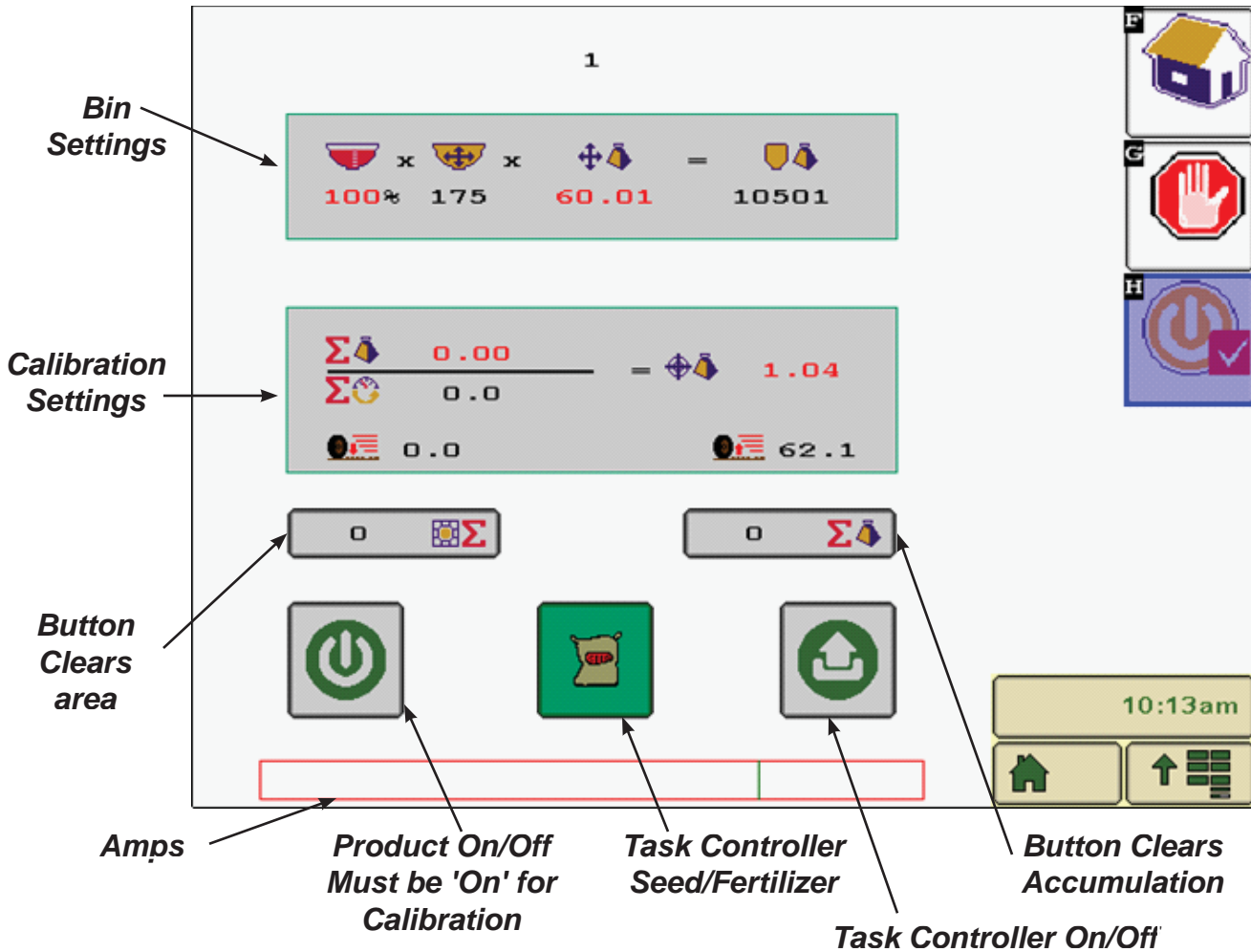

Dry Product Screen Softkeys			
Icon	Page	Icon	Page
	Main (Home)		On/Off (Manual Work Switch)
	Product On/Off		

System Settings Screen

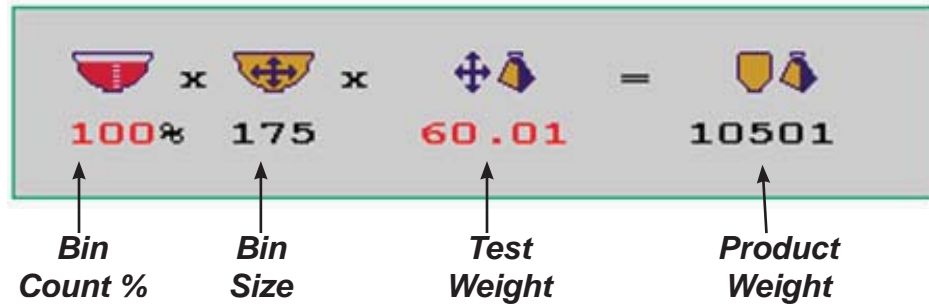

Bin Size (Volume)

Bin Size displays the size of the tank in **bushels (liters)**. This value is pre-set at the factory and is used for the Bin Count and Product Weight features.

Bin Count %

Enter the percentage of estimated product in the bin each time the tank is filled. When calibrated properly, the Bin Count feature provides an estimated approximation of the product left in that bin. This percentage is displayed on the status bar on the Home Screen.

Product Weight/Volume (Density or Test Weight)

Enter the test weight of your product in **Pounds/bushel (Kg/liter)**. This value is needed for proper operation of the "Bin Count" feature.

Product Weight

Displays estimated remaining product weight in the bin in **Pounds (Kg)**.

Selecting Air Stream (Dual Chute Only)

In dual chute equipped systems; one can switch air streams for any desired product combination.

To switch air streams:

- 1.Remove wing nuts from baffle slide & plug
- 2.Remove slide and direct into the air stream desired
- 3.Replace plug and wing nuts

Note

Do not use wrench to tighten wing nuts. Over tightening will cause failure to stud (330031).

- 4.Switch pressurization tube to the desired stream.

Note

If switching frequently:

Apply small amounts of Anit-Seize to stainless studs. This will prevent them from seizing and breaking off.



Caution!

If the pressurization tube is not switched seeding rates will become inaccurate.

Adjusting Product Meters

The product meters deliver seed or fertilizer from the product bins to the air stream via a fluted roller. The amount of the roller that is being used determines the rate at which products are applied.

There are two moveable components in the meter that determine the rate setting.

The primary setting is a flow plate adjusted by a rod connected to a pointer. When a rate setting is selected, the pointer is simply placed by measuring from the meter slide fully close to the desired number on the tape measure. A lock bolt on the pointer rod secures the setting.

The second part of the adjustment is the meter shut off slide. For any rate setting the proper place for shut off slide is against the stop on the pointer. This opens the bottom of the tank compartment the proper amount for the rate setting. A ½" drive ratchet supplied in the toolbox is used to adjust the meter shut off slide.

Any time that a new rate is set, the rate setting should be confirmed by calibrating the meter.

A scale and catch bag are supplied in the tool box for calibration.

Once a rate setting is determined from the rate charts and the meter is set to that setting, perform the following calibration procedures.

When using all of the tanks for one product, determine the rate for each meter by splitting the desired rate by the ratio of the tanks (33/43/24). This will result in all tanks emptying at the same time.

Example

If you desire to seed 120 lbs of wheat using all meters, split the desired pounds per acre rate to the ratio of the size of the tanks. i.e. If the Air Cart is a 33/43/24 split, set the meters as follows: 39.6 lbs (120.33), 51.6 lbs (120*.43), and 28.8 lbs (120*.24)*

Note

When decreasing the meter setting, it may be necessary to close the shutoff slide and turn the meter to empty it. This will empty the meter and allow the plate to move to a smaller setting.

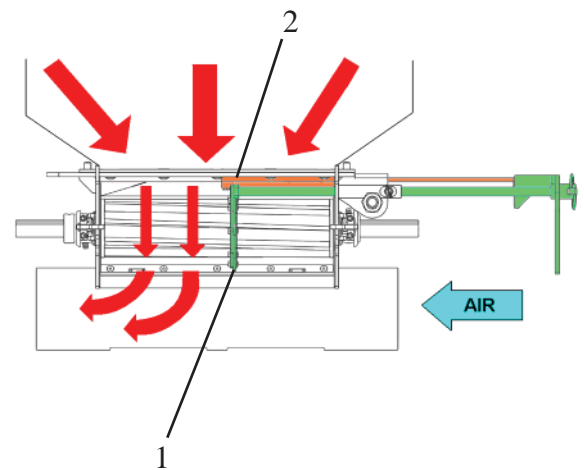
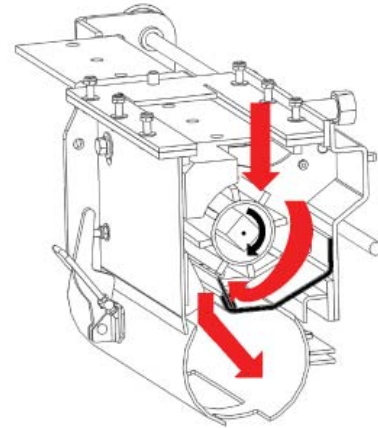

Note

Plate (1) controls how much of meter roller will be used. The shut off slide (2) is opened to the stop on the pointer for any rate setting. When making large rate reductions, close the slide and empty the meter to allow the plate to move to the lower setting. Remember to reopen the slide until it contacts the stop on the pointer.

Hydraulic Drive Calibration and Operation

Calibration is done in four parts. First, you must prepare the system for calibration. Second, you prime the meter. Third, you take a sample and weigh it. Finally, you enter the sample, or Accumulated weight into the virtual terminal.

Preparing to Calibrate the Meter

Hydraulic power is needed for calibration. The following procedure sets up the air cart for the calibration procedure.

1. Ensure that the air cart's hydraulic lines are connected to a tractor.
2. Verify that the tractor hydraulic remote for the blower is in neutral until hydraulic power is needed.
3. Ensure that the monitor wire harness is properly connected to the tractor.
4. Power up the monitor in the tractor.
5. Verify that the VT in the cab is communicating with the Air Cart ECU.
6. Ensure that the meter door is properly attached to the meter.
7. Ensure the bin is at least 25% full of the product that will be applied.
8. Set the meter gate to the appropriate position for the rate being applied.
9. Ensure the auger selector valve is directing oil to the fan/meter circuit.
10. Close the blower ball-valve.
11. Actuate the tractor remote controlling the blower circuit.
12. Make sure the blower is not spinning for the following steps. If the blower is spinning, check the ball valve to make sure that it is full closed and blocking all flow to the blower..
13. Open the cleanout door below the meter you wish to calibrate.



The Auger Selector Valve



Adjusting the Meter Gate

The meter must be calibrated if:

- *The gate setting has been changed*
- *A different product is being used*
- *A different meter roll is being used*

Each meter must be calibrated individually, even if all the gates are set the same.

Meter Gate Setting Guide – Hydraulic Drive - High Capacity Meter Roll				
Rate lbs/ac <i>(kg/Ha)</i>	30 ft <i>(9m)</i>	40 ft <i>(12m)</i>	50 ft <i>(15m)</i>	60 ft <i>(18m)</i>
50 (56)	3" (76 mm)	4" (102 mm)	5" (127 mm)	6" (152 mm)
100 (112)	4" (102 mm)	6" (152 mm)	8" (203 mm)	10" (254 mm)
150 (168)	6" (152 mm)	8" (203 mm)	10" (254 mm)	Max
200 (224)	8" (203 mm)	10" (254 mm)	Max	Max

Priming the Meter

To ensure accurate calibration, the meter must be primed with product.

1. On the ECU keypad, locate the button with the number corresponding to the meter you are calibrating. This is called the ECU Calibration button.
2. Press the ECU Calibration button once.
The meter roll begins spinning.
3. Allow the meter to spin 2 to 3 revolutions to ensure that the meter is full of product.
4. Press the same button again to stop the meter.
The meter is now primed.

Note

Each time the calibration button on the ECU is pressed to activate the meter the ECU counts the revolutions of the meter roll. This count is reset each time this process is performed. Once you stop the meter roll, the bag must be weighed. If you did not collect enough product in the bag to obtain a measurable weight, you must dump the bag and start over with an empty bag.

Taking a Sample for Calibration

1. Using the weigh scale included with your system, hang the calibration bag (also included) on the scale and turn the adjustment dial to zero out the weight of the bag.
2. Place the calibration bag below the cleanout opening.
Be careful to ensure all product will flow into the bag.
3. Press the ECU Calibrate button to activate the meter.
4. Allow the meter to spin until the bag is at least half full.
5. Press the ECU Calibrate button again to stop the meter.
6. Weigh the bag with the supplied scale.
7. Convert the weight to pounds and record the value.

This value is the Accumulated Weight value you will enter into the VT.

Note

Do not press the ECU Calibrate button again until the Accumulated weight is entered into the VT. Pressing the ECU Calibrate button before the weight is entered will clear the rotation counter and void the sample.

8. Repeat the previous steps to obtain sample weights for the rest of the meters.
9. When all the weights have been found, go back to the tractor and enter the calibration weights into the Product page on the Virtual Terminal.



Note

To calibrate a product meter it must be enabled (active) on its Product page.

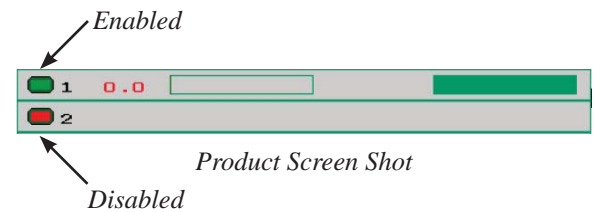

Entering Accumulated Weight into the Monitor

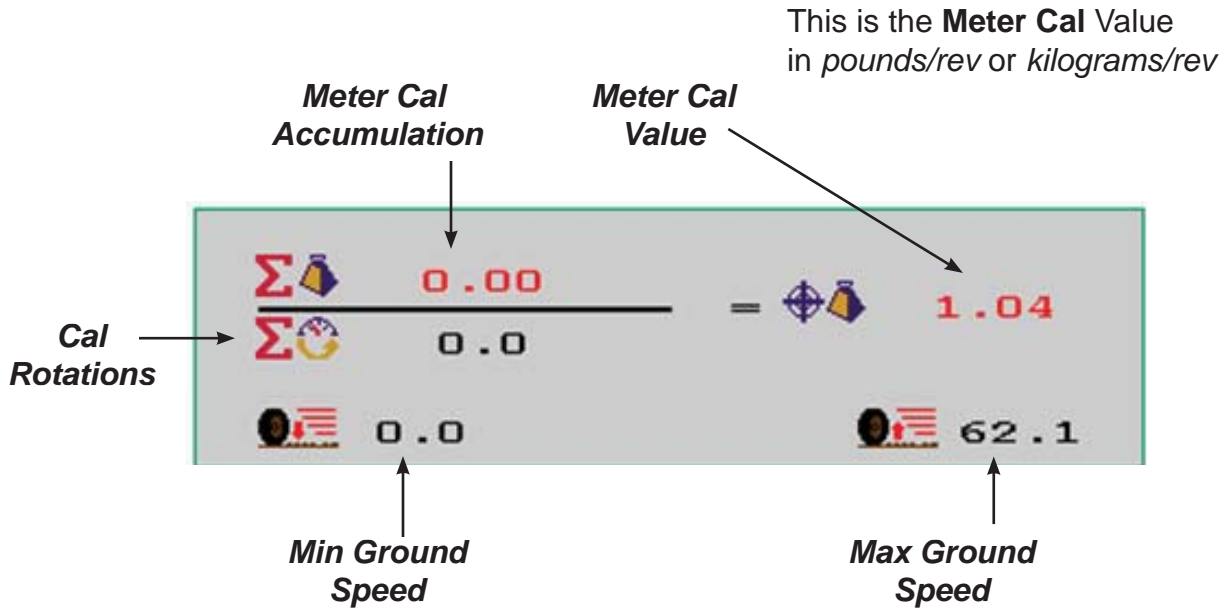

About Meter Cal

Once you enter the **Accum** (lb) value (in Step 3) the ECU automatically calculates the **Meter Cal** value. The **Meter Cal** value is the number of pounds (lb) of product applied per revolution of the meter roller.

E.g. If the **Meter Cal** value is 1.50, the meter will deliver 1.50 lb of material during each revolution of the meter roll.

Step 1. With an accumulated weight value, return to the virtual terminal monitor.

Step 2. On the Main (Home) page,  5 press the soft key for the desired product.

The Product page for the selected product appears.

Step 3. On the Product page, select the number next to **Meter Cal Accumulation**. 

Step 4. Enter the accumulated weight value obtained in previous meter calibration procedure in pounds (kilograms).

Step 5. Press Home soft key to return to the Main (Home) page.

Repeat Steps for each additional bin.

THIS PAGE
INTENSIONALLY
LEFT BLANK

WHEAT

High Capacity Flute P/N 65705
1/4" WIDE X 1/2" DEEP BARS

GROUND DRIVE ONLY
17T GEAR BOX SPROCKET W/ 18.4 R26 TIRES
15T GEAR BOX SPROCKET W/ 23.1 R26 TIRES

WIDTH (FT)	APPLICATION RATE (LBS PER ACRE)																		
	60	70	80	90	100	110	120	130	140	150	160	170	180	190	200	210	220	230	240
20	2.7	3.1	3.6	4.0	4.5	5.0	5.4	5.8	6.3	6.7	7.2	7.6	8.1	8.5	8.9	9.4	9.8	10.3	10.8
25	3.4	3.9	4.5	5.0	5.6	6.2	6.8	7.3	7.8	8.4	8.9	9.5	10.1	10.6	11.2	11.8	12.3	12.9	13.4
30	4.1	4.7	5.4	6.0	6.8	7.4	8.1	8.8	9.4	10.1	10.7	11.4	12.1	12.8	13.4				
35	4.7	5.5	6.3	7.0	7.9	8.7	9.5	10.2	10.9	11.7	12.5	13.3							
40	5.4	6.3	7.2	8.0	9.0	9.9	10.8	11.7	12.5	13.4									
45	6.1	7.1	8.1	9.0	10.1	11.1	12.2	13.2											
50	6.8	7.9	9.0	10.0	11.3	12.4	13.5												
55	7.4	8.7	9.9	11.0	12.4	13.6													
60	8.1	9.4	10.8	12.0	13.5														

APPROXIMATE POINTER SETTING

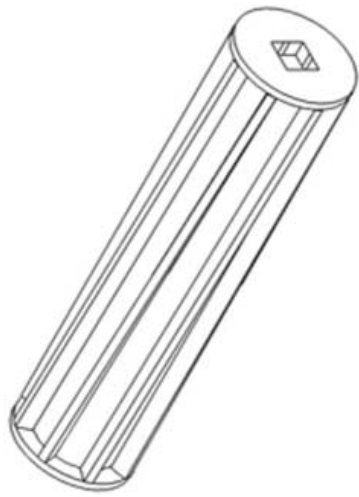
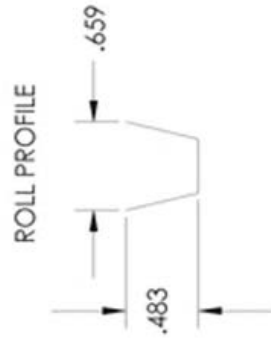

FERTILIZER (60 LBS PER CUBIC FT.)

High Capacity Flute P/N 65705
 1/4" WIDE X 1/2" DEEP BARS

GROUND DRIVE ONLY
 17T GEAR BOX SPROCKET W/ 18.4 R26 TIRES
 15T GEAR BOX SPROCKET W/ 23.1 R26 TIRES

WIDTH (FT)	APPLICATION RATE (LBS PER ACRE)																		
	60	70	80	90	100	110	120	130	140	150	160	170	180	190	200	210	220	230	240
20	2.3	2.7	3.1	3.5	3.8	4.2	4.6	5.0	5.4	5.8	6.1	6.5	6.9	7.3	7.7	8.1	8.4	8.8	9.2
25	2.9	3.4	3.8	4.3	4.8	5.3	5.8	6.2	6.7	7.2	7.7	8.2	8.6	9.1	9.6	10.1	10.6	11.0	11.5
30	3.5	4.0	4.6	5.2	5.8	6.3	6.9	7.5	8.1	8.6	9.2	9.8	10.4	10.9	11.5	12.1	12.7	13.2	13.8
35	4.0	4.7	5.4	6.0	6.7	7.4	8.1	8.7	9.4	10.1	10.8	11.4	12.1	12.8	13.4				
40	4.6	5.4	6.1	6.9	7.7	8.4	9.2	10.0	10.8	11.5	12.3	13.1	13.8						
45	5.2	6.0	6.9	7.8	8.6	9.5	10.4	11.2	12.1	13.0	13.8								
50	5.8	6.7	7.7	8.6	9.6	10.6	11.5	12.5	13.4										
55	6.3	7.4	8.4	9.5	10.6	11.6	12.7	13.7											
60	6.9	8.1	9.2	10.4	11.5	12.7	13.8												

APPROXIMATE POINTER SETTING

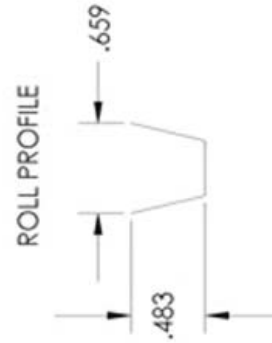
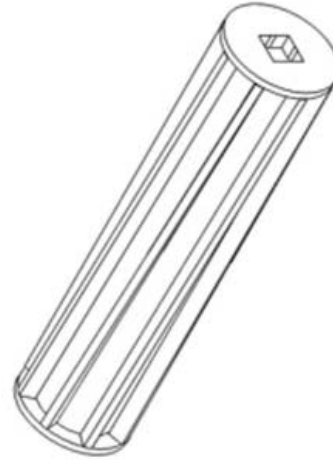

SOYBEANS

High Capacity Flute P/N 65705
1/4" WIDE X 1/2" DEEP BARS

GROUND DRIVE ONLY
17T GEAR BOX SPROCKET W/ 18.4 R26 TIRES
15T GEAR BOX SPROCKET W/ 23.1 R26 TIRES

WIDTH (FT)	APPLICATION RATE (LBS PER ACRE)																		
	60	70	80	90	100	110	120	130	140	150	160	170	180	190	200	210	220	230	240
20	3.1	3.6	4.1	4.6	5.2	5.7	6.2	6.7	7.2	7.7	8.2	8.8	9.3	9.8	10.4	10.9	11.4	11.9	12.4
25	3.9	4.5	5.2	5.8	6.4	7.1	7.8	8.4	9.0	9.6	10.3	10.9	11.6	12.2	12.9	13.6			
30	4.7	5.4	6.2	6.9	7.7	8.6	9.3	10.1	10.8	11.6	12.3	13.1	13.9						
35	5.4	6.3	7.2	8.0	9.0	10.0	10.9	11.7	12.6	13.5									
40	6.2	7.2	8.3	9.2	10.3	11.4	12.4	13.4											
45	7.0	8.1	9.3	10.4	11.6	12.8	14.0												
50	7.8	9.1	10.3	11.5	12.9	14.0													
55	8.5	10.0	11.4	12.6	14.2														
60	9.3	10.9	12.4	13.8															

APPROXIMATE POINTER SETTING

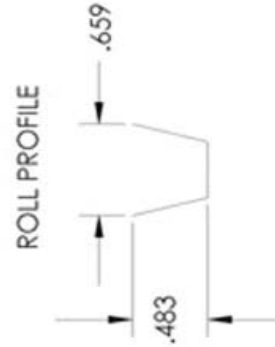
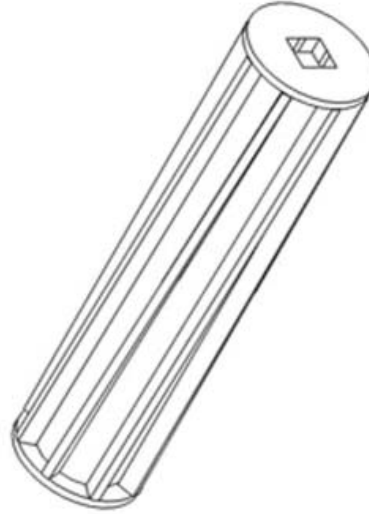

BARLEY

High Capacity Flute P/N 65705
1/4" WIDE X 1/2" DEEP BARS

GROUND DRIVE ONLY
17T GEAR BOX SPROCKET W/ 18.4 R26 TIRES
15T GEAR BOX SPROCKET W/ 23.1 R26 TIRES

APPLICATION RATE (LBS PER ACRE)

WIDTH (FT)	APPLICATION RATE (LBS PER ACRE)																		
	60	70	80	90	100	110	120	130	140	150	160	170	180	190	200	210	220	230	240
20	3.4	3.9	4.5	5.0	5.6	6.2	6.7	7.3	7.8	8.4	8.9	9.5	10.1	10.7	11.2	11.8	12.3	12.9	13.4
25	4.2	4.9	5.6	6.3	7.0	7.7	8.4	9.1	9.8	10.5	11.2	11.9	12.6	13.3					
30	5	5.8	6.7	7.6	8.4	9.2	10.1	10.9	11.8	12.6	13.4								
35	5.9	6.8	7.8	8.8	9.8	10.8	11.7	12.8	13.7										
40	6.7	7.8	8.9	10.1	11.2	12.3	13.4												
45	7.5	7.0	10.0	11.4	12.6	13.8													
50	8.4	9.8	11.1	12.6	14.0														
55	9.2	10.7	12.2	13.9															
60	10.1	11.7	13.4																

APPROXIMATE POINTER SETTING

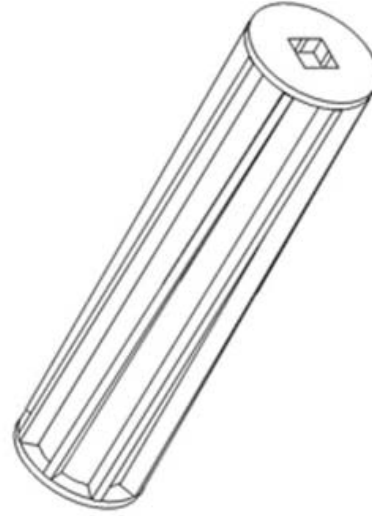

ROLL PROFILE

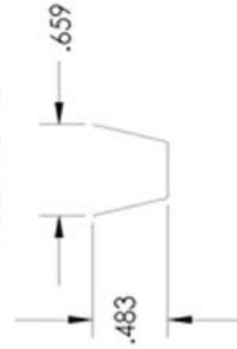

CANOLA

FINE PRODUCT METER ROLL P/N 67639
1/2" WIDE X 1/8" DEEP SLOTS

GROUND DRIVE ONLY
17T GEAR BOX SPROCKET W/ 18.4 R26 TIRES
15T GEAR BOX SPROCKET W/ 23.1 R26 TIRES

WIDTH (FT)	3	4	5	6	7	8	9	10	11	12	13	14	15
20						0.8	1.4	2.1	2.8	3.5	4.2	4.9	5.6
25			0.4	1.3	2.1	3	3.9	4.7	5.6	6.4	7.3	8.2	
30		0.4	1.4	2.5	3.5	4.5	5.6	6.6	7.6	8.7	9.7	10.7	
35		1.3	2.5	3.7	4.9	6.2	7.3	8.5	9.7	10.9	12.1	13.3	
40	0.8	2.1	3.5	4.9	6.3	7.6	9	10.4	11.8	13.1			
45	1.4	3	4.5	6.1	7.6	9.2	10.7	12.3					
50	0.4	2.1	3.9	5.6	7.3	9	10.7	12.5					
55	0.9	2.8	4.7	6.6	8.5	10.4	12.3						
60	1.4	3.5	5.6	7.6	9.7	11.8							

APPROXIMATE POINTER SETTING

ROLL PROFILE

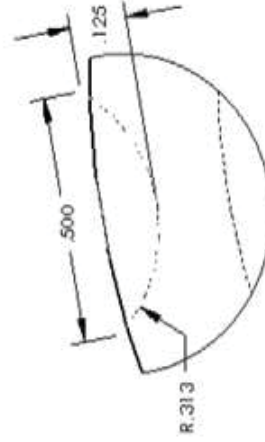

DETAIL A
SCALE 4 : 1

NOTE:

1. ALL SLOTS ARE .125" DEEP
2. ALL SLOTS ARE 1.00" LONG
3. 1.50 SLOT OFFSET WITHIN ROWS



MECHANICAL SYSTEMS - MAINTENANCE AND TROUBLESHOOTING

Routine Maintenance

Hinge Points

Lubricate seasonally with SAE multipurpose grease.

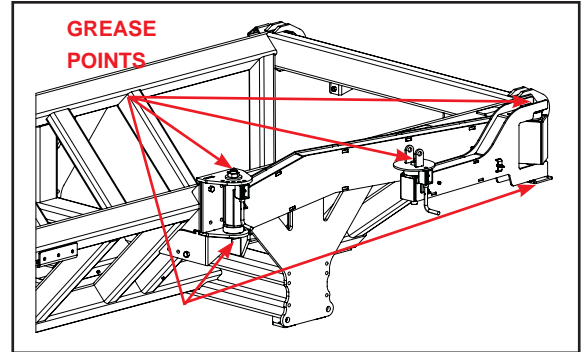

Meter Box

Lubricate all drive components every 50 hours with SAE multipurpose grease

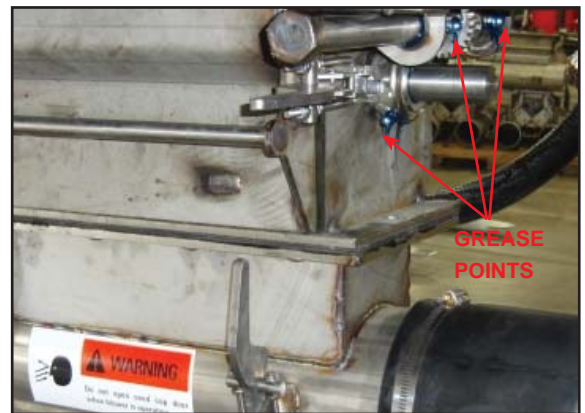

Hydraulic Motor

The hydraulic motor can only be damaged by heat or foreign material. Keep your tractor hydraulic oil and filter serviced regularly to ensure long life from your hydraulic components.



Wheel Bearings

Annually check wheel bearings for tightness. Adjust if needed. Repack every three (3) years.



Changing Metering Rolls - Hydraulic drive System

To change metering rolls on a VR System:

1. Close the meter gate or ensure the bin is empty.
2. Remove the meter door and set aside.
3. Remove (2) 5/8" stainless bolts on the meter flange.
4. Loosen set screw on coupler.
5. Slide motor and coupler off the shaft.
6. Remove the two nuts that hold the bearing on the meter shaft (motor-end only).
7. Pull the shaft out of the meter (with the motor still attached) while holding on to the meter roll.
8. Remove the meter roll.
9. Re-assemble the meter in reverse order with the desired meter roll.



Meter Roll Options

Amity's standard high capacity and optional medium capacity meter rollers are constructed of stainless steel for lifetime performance

Four meter roll options are available.

The high capacity roll has eight 1/2" deep bars and is used for most applications.

The medium capacity roll has twelve 1/4" deep bars and is used on smaller machines or for consistently lower seeding or fertilizer rates.

The low volume has a pattern of short, shallow depressions to gradually larger, deeper depressions for very low seeding rate.

The fine product meter roll has a continuous pattern of shallow depressions for very low seeding rates with high accuracy.

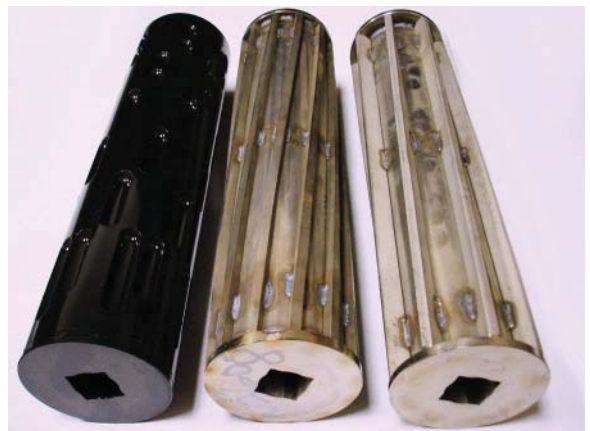

Other Meter Adjustments

The following adjustments are done at the factory and should only be done by a trained service technician.

Shims

- The meter roll should have a small gap (.030") between the roll and the meter housing for proper operation. If the gap is too large product can leak around the meter roll into the air stream. If the gap is too tight the meter roll will bind on the housing and cause problems with the meter drive system.
- A .030" thick shim (Amity P/N 65744) can be installed between the meter roll and the meter housing to reduce this gap. The meter shaft needs to be removed to install this shim, see the section on changing meter rolls on the procedure to remove the shaft.
- Ensure the meter roll turns freely after installing or removing any shims. If the meter roll does not turn freely, DO NOT operate the air cart until enough shims have been removed to allow the meter roll to turn freely.



Deflector Block

The black plastic deflector block in the rear of the meter prevents seed from flowing around the back side of the meter roll. If needed, this block can be adjusted vertically to increase or decrease the clearance to the meter roll. To adjust, loosen the two nuts on the back side of the meter housing, move the block to the desired position, and tighten the nuts to lock the block into place.

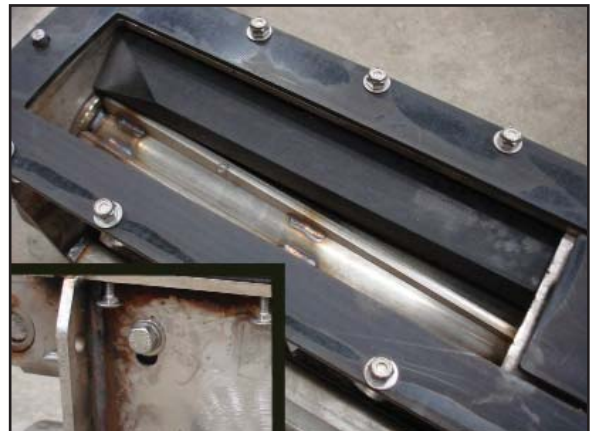

Meter Door Tray

The tray on the meter door can be adjusted vertically in order to increase or decrease the tension between the rubber seal on the tray and the meter roll. To adjust, loosen the three nuts holding the tray to the meter door, move the tray to the desired position, and tighten the nuts to lock the tray into place.



Meter Door and Cleanout Door Latches

The tension on these latches can be adjusted to increase or decrease the preload on the meter door and the cleanout door. If the preload is too small, the doors will not seal properly. If the preload is too tight, the latches will be difficult to close. The tension can be adjusted by unlocking the latch and screwing the two stop-nuts evenly in or out. Ensure the door preload is adequate before putting the unit back into service.

Mechanical Systems Troubleshooting: Common Problems and Solutions

Symptom	What it means	Recommended Action
Seed cups will not engage	Product is off	Turn product on from VT
	Minimum speed condition not met.	Be sure unit is moving faster than minimum speed setting
Seed is flowing without cups turning. (A small amount of seed flow is normal and not a cause for concern.)	Rubber deflector is not down tightly on flute.	Lower the deflector.
	Rubber wiper on seed cup door damaged or not up tightly against flute.	Raise door or replace rubber wiper if damaged.
	Product is building up in air delivery system.	Increase blower speed.
Excessive seed cracking is occurring	Air stream velocity is too great.	Reduce blower speed or adjust blower baffle on dual air stream machines.
Seed boots are plugging	Turning corners too sharply with boots in the ground.	Always raise ground opener before making a sharp turn.
	Ground openers have been left in the ground when backing up.	Always raise ground opener before backing up.
Product distribution is uneven	A one inch hose may be plugged.	Re-route or cut 1" hoses to eliminate sags. Clear any obstruction in hoses or boots.
	Splitter not calibrated.	Calibrate splitter equally
	Pressurization tube in wrong stream (dual chute only).	Switch to stream being used
Uneven delivery rate	Loss of tank pressure.	Check tank lids for leaks. Inspect and replace faulty gaskets.
Oil showing up on seed lines	Shaft seal failure on hydraulic motor.	Replace seal. WARNING: DO NOT DISASSEMBLE HYDRAULIC MOTOR!! THE SHAFT SEAL IS AN EXTERNAL REPLACEMENT ITEM.
Hydraulic motor slow	Monitor set to wrong blower speed setting (See Monitor Section).	See Monitor Section
	Tractor is not putting out adequate oil.	Have tractor dealer inspect tractor hydraulics.
	Bad couplers.	Check couplers on tractor and hoses. Try different couplers.
Cannot hook up hydraulic lines	Back pressure on the system is preventing the couplers to release	Press relief button on control block located near fan on front of the cart

Storage

- Fully open the seed meters.
- Open clean out doors on the bottom of the air tube.
- Clean any remaining product from tanks.
- Use water to thoroughly clean any compartment used for fertilizer
- Thoroughly clean fertilizer and dirt from cup area.
- Clean the inside of the seed meter door. Fertilizer, seed and dirt accumulate in this area.
- Clean any remaining product from the auger and leave the auger slide open.
- Grease all lubrication points.
- Release the latch on the tank lids to relieve pressure on the lid gaskets.

APPENDIX: CONNECTOR PINOUTS

ECU Signal Connectors



<i>Left Connector (Black Body)</i>		<i>Center Connector (Grey Body)</i>	<i>Right Connector (Blue Body)</i>		
<i>Pin #</i>	<i>Function</i>	<i>Pin #</i>		<i>Pin #</i>	<i>Function</i>
1	Motor 1 Power	1		1	Bin 3 Signal
2	Motor 4 Power	2		2	Meter 3 Signal
3	CAN Comm. High	3		3	
4	Bin 1 Signal	4		4	
5	Meter Box 1 Signal	5		5	
6		6		6	
7	Meter Box 2 Signal	7		7	
8	Motor 1 Ground	8		8	
9	Bin 2 Signal	9		9	
10	Motor 3 Ground	10	Sensor Power (12V)	10	
11	Speed Signal	11		11	
12	Motor 3 Power	12		12	
13	Fan 1 Signal	13		13	
14	Fan 2 Signal	14		14	
15	CAN Comm. Low	15		15	
16		16		16	
17	Tach 1 Ground	17		17	
18	Tach 2 Ground	18		18	
19	Tach 3 Ground	19		19	
20	Tach 2 Signal	20		20	
21	Tach 4 Ground	21	Sensor Ground	21	
22	ECU Ground	22		22	
23	ECU Power	23		23	
24	Tach 1 Signal	24		24	
25	Motor 2 Ground	25		25	
26	Motor 2 Power	26		26	
27	Tach 4 Signal	27		27	
28	Tach 1 Power	28		28	
29	Tach 2 Power	29		29	
30	Tach 3 Power	30		30	Bin 4 Signal
31	Tach 4 Power	31		31	
32	Work Signal	32		32	Meter 4 Signal
33	Motor 4 Ground	33		33	
34	Tach 3 Signal	34		34	
35		35		35	

ISO-BUS Connector

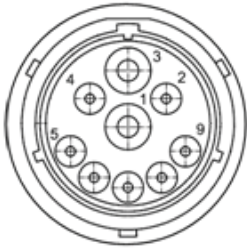

Pin #	Function
1	Battery Negative
2	ECU Ground
3	Battery Positive
4	ECU Power
5	TBC_DIS
6	TBC_PWR
7	TBC_RTN
8	CAN H
9	CAN L

Note:

- Battery Positive and Negative on double 8AWG wiring to reduce voltage drop between battery and ECU power terminals in high current systems.
- Dust cap provided to protect connector when not in use

CAN Terminator Connector



Pin #	Function
A	
B	TBC PWR
C	
D	TBC RTN
E	CAN H
F	CAN L

Note:

- Connector mates with Powell TBC. TBC (CAN BUS terminating bias circuit) should only be installed at the physical end of the CANBUS system.
- Terminated in Metripack 12052848 connector (150 Series)

ECU Power Contacts



Pin #	Function
N/A	Battery Positive (red)
N/A	Battery Negative (black)

Note:

- #10 (M5) ring terminal connects to ECU power terminals.
- Battery Positive and Negative on double 8AWG wiring to reduce voltage drop between battery and ECU power terminals in high current systems.
- Caution! – reverse polarity power connection will damage ECU

Motor Control Connectors



Pin #	Function
1	Motor Power
2	Motor Ground

Note:

- Electric motor or electric over hydraulic control is possible
- Terminated in Deutsch DT06-2S connector, contacts rated to 13 amps, 16AWG wiring
- Mating connector is Deutsch DT04-2P

Motor Speed (Tach) Connectors



Pin #	Function
1	Tach Power
2	Tach Signal
3	Tach Ground

Note:

- Connector mates with Powell TBC. TBC (CAN BUS terminating bias circuit) should only be installed at the physical end of the CANBUS system.
- Terminated in Metripack 12052848 connector (150 Series)

Low-Bin Level Sensor Connectors



Pin #	Function
1	Bin Power
2	Bin Signal
3	Bin Ground

Note:

- Independent feedback for up to 4 bin level sensors (infrared, capacitive proximity)
- Mates directly to Agtron bin level sensors, 3rd party sensors may require additional wiring
- Terminated in Deutsch DTM06-3S connector, contacts rated to 7 amps, 20AWG wiring
- Mating connector is Deutsch DTM04-3P

Meter Box Sensor Connectors



Pin #	Function
1	Meter Power
2	Meter Signal
3	Meter Ground

Note:

- Independent feedback for up to 4 additional bin level sensors (infrared, capacitive proximity)
- Mates directly to Agtron bin level sensors, 3rd party sensors may require additional wiring
- Terminated in Deutsch DTM06-3S connector, contacts rated to 7 amps, 20AWG wiring
- Mating connector is Deutsch DTM04-3P

Ground Speed Sensor Connectors



Pin #	Function
1	Speed Power
2	Speed Signal
3	Speed Ground

Note:

- *Ground speed sensor feedback (hall effect, reed switch, inductive)*
- *Mates directly to Agtron inductive and reed switch sensors, 3rd party sensors may require additional wiring*
- *Wiring is common between the radar and speed sensor connections; only one speed source can be used.*
- *Terminated in Deutsch DTM06-3S connector, contacts rated to 7 amps, 20AWG wiring*
- *Mating connector is Deutsch DTM04-3P*

Fan Sensor Connectors



Pin #	Function
1	Fan Power
2	Fan Signal
3	Fan Ground

Note:

- *Independent feedback for up to 2 fan RPM sensors (hall effect, reed switch, inductive)*
- *Mates directly to Agtron inductive and reed switch sensors, 3rd party sensors may require additional wiring*
- *Terminated in Deutsch DTM06-3S connector, contacts rated to 7 amps, 20AWG wiring*
- *Mating connector is Deutsch DTM04-3P*

Anhydrous Ammonia/Liquid Control Connector



Pin #	Function
A	Flowmeter Signal
B	Battery Positive
C	Flowmeter Ground
D	N/A
E	Flowmeter Power
F	Shutoff Valve Ground
G	Rate Control Valve Negative
H	Rate Control Valve Positive
J	Shutoff Valve Power
K	Battery Negative

Note:

- Terminated in Metripack 150 series 10 pin receptacle
- Mates directly to Micro-Trak harness part number 13273.
- Adaptors for the Raven Accu-Flow system available.

Approximate Tank Fill Percentages

Approximate Tank Fill Percentages					
Ladder Rung (from top)	Model 2800	Model 3350	Model 5250		
	Front & Rear	Front & Rear	Front	Middle	Rear
1st	90%	85%	99%	99%	99%
2nd	75%	60%	85%	90%	85%
3rd	45%	35%	65%	65%	65%
4th	15%	15%	45%	40%	45%
5th	5%	5%	20%	15%	20%
6th	N/A	N/A	5%	5%	5%

Advanced Screens



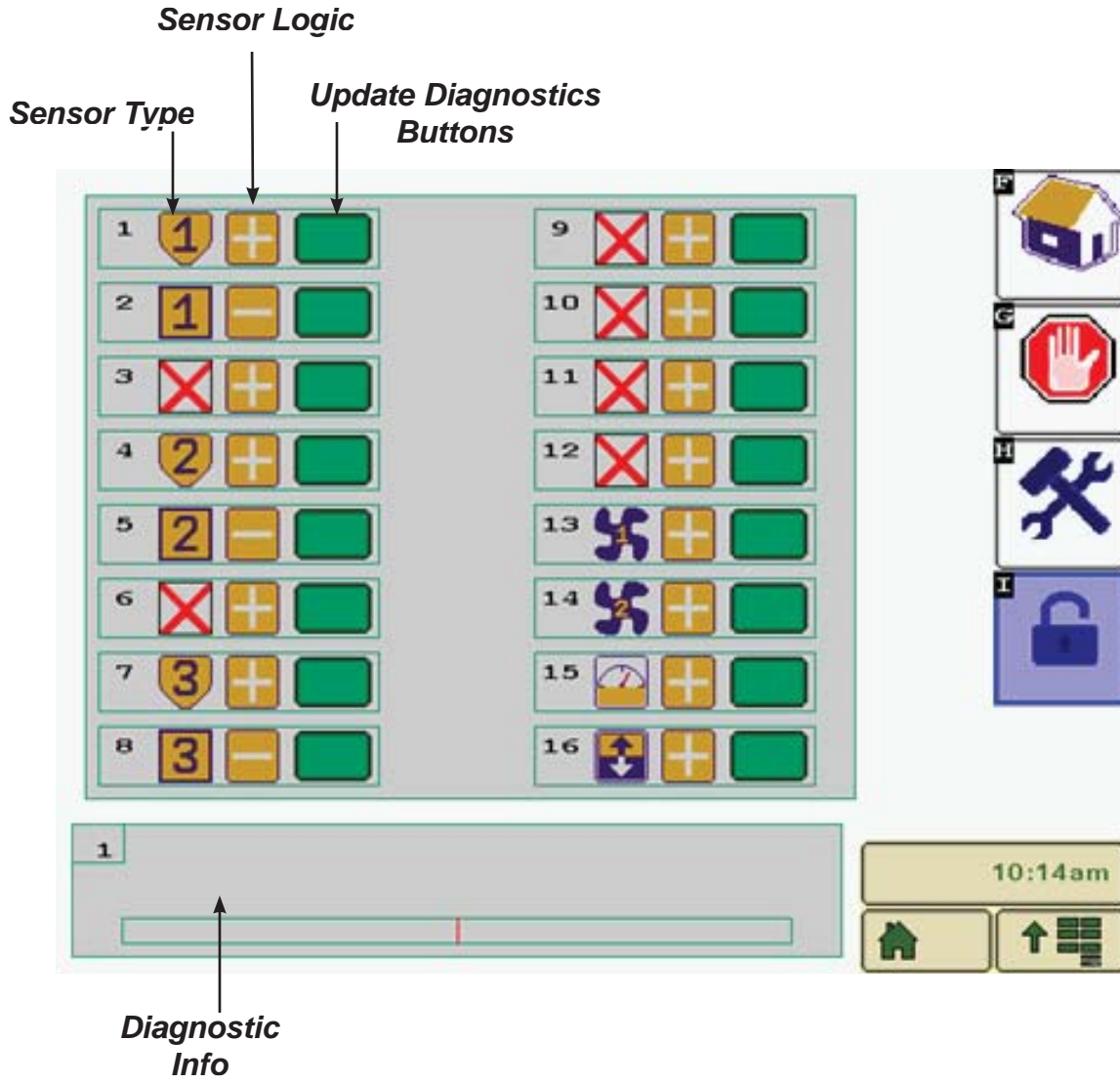



	Bin 1	Bin 2	Bin 3	Bin 4	Bin 5	NH3
	1	2	3	4	5	N
Product Enable						
GND/HYD Drive						
Tank Size		175	225	125		1500
Target Rate		0.0	0.0	0.0		0.0
Actual Rate		0.0	0.0	0.0		0.0
Implement Width		480	480	480		480
Minimum RPM		10	10	10		
Maximum RPM		100	100	100		
Calibration RPM		25	25	25		
Target RPM		0	0	0		0
Actual RPM		0	0	0		0
Drive A Current Overload		15.0	15.0	15.0		10.0
Drive B Current Overload						7.5
Drive Gain		50	50	50		50
Tach Targets/Rev		60	60	60		
Allowable Error %		10	10	10		20
Fixed PWM% Output Override		0	0	0		
Drive Direction						
Drive Frequency						100
NH3 Valve Type						2



Cart ECU Sensor Channel Info

- | | |
|-----------------|-------------------------------------|
| 1 – Bin 1 | 9 – N/A |
| 2 – Meter Box 1 | 10 – Bin 4 |
| 3 – N/A | 11 – Meter Box 4 |
| 4 – Bin 2 | 12 – N/A |
| 5 – Meter Box 2 | 13 – Fan 1 |
| 6 – N/A | 14 – Fan 2 (Opt.) |
| 7 – Bin 3 | 15 – Ground Speed (ECU Input) |
| 8 – Meter Box 3 | 16 – External Automatic Work Switch |

Sensor Types

Symbol	Sensor Type
	Bin 1-4
	Meter Box 1-4
	Fan 1-2
	Ground Speed
	Internal Work Switch
	External Work Switch
	None

