

Amity

TECHNOLOGY



OWNERS OPERATING & PARTS MANUAL



2800 & 3350

2012 AIR SYSTEM

P/N 330282

Amity Technology, LLC
2800 7th Avenue North
Fargo, ND 58102
(701) 232-4199
www.amitytech.com

AMITY TECHNOLOGY, LLC LIMITED WARRANTY FOR NEW PRODUCTS

1. **General Provisions.** This Warranty shall apply to the original purchaser of (1) any new and unused machine manufactured by Amity Technology, LLC ("Amity"), and (2) any new and unused part which is manufactured by Amity for use in an Amity machine, jointly referred to as "Products," whether such Product is purchased through a dealer or directly from Amity. Under this Warranty, Amity will repair or replace, as it chooses in its sole discretion, any covered Product, or any component thereof, which Amity determines to be defective. This Warranty shall be in effect for a period of twelve (12) months ("the Warranty Period"), beginning on the date of delivery of the covered machine or part by the dealer or Amity to the purchaser ("the Warranty Start Date"). The purchaser must pay the cost of transportation of a Product to be repaired or replaced to and from an authorized Amity dealer. This Warranty may not be transferred from the original purchaser of a Product to any other person. This Warranty does not give a purchaser the right to any relief other than repair or replacement of the Product, and it specifically does not allow for consequential or incidental damages, exemplary or punitive damages, or costs and fees.
2. **Scope and Limitations of Warranty.** With respect to machines, this Warranty is void if any part not supplied by Amity is used in assembly or repair of the machine, or if the machine has been altered, abused or neglected, as determined by Amity. With respect to parts, this Warranty is void if the part is used in any manner other than that for which it is intended. This Warranty does not extend in any way to tires and any other component of a Product warranted by another manufacturer, a copy of which warranty is provided herewith ("Third-Party Warranties"). In the event Amity determines that a Product is not defective, or that any other provision of this Paragraph 2 operates to limit the Warranty, this Warranty shall not apply and the purchaser shall be responsible for transporting the Product from the authorized Amity dealer's location within 10 days of notice by Amity.
3. **Procedures for Obtaining Service.** To secure Warranty service, a purchaser must (1) report the defect to an authorized dealer and request repair within 45 days of the failure and within the Warranty Period; (2) present evidence that this Warranty applies to the Product; (3) present evidence of the Warranty Start Date; and (4) bring the Product to an authorized Amity dealer within a reasonable period of time after reporting the defect.
4. **LIMITATION OF IMPLIED WARRANTIES AND OTHER REMEDIES.** To the extent allowed by law, neither Amity, its dealers, nor any company affiliated with Amity makes any warranties, representations, or promises as to the quality, performance, or freedom from defect of any Product covered by this Warranty.
AMITY HEREBY WAIVES, TO THE EXTENT APPLICABLE, ANY AND ALL IMPLIED WARRANTIES OF MERCHANTABILITY AND FITNESS FOR A PARTICULAR PURPOSE. A PURCHASER'S ONLY REMEDIES IN CONNECTION WITH THIS WARRANTY ARE THOSE SET FORTH ON THIS PAGE. IN NO EVENT WILL AMITY, ITS DEALERS, OR ANY COMPANY AFFILIATED WITH AMITY BE LIABLE FOR INCIDENTAL, CONSEQUENTIAL OR PUNITIVE DAMAGES.
Some states do not allow waivers of certain warranties, so the above waivers may not apply to you. You may also have other rights which vary from state to state.
5. **No Dealer Warranty.** This is the exclusive warranty applicable to Amity Products. No dealer has any authority to make any other warranty, modify, limit, or expand the terms of this Warranty in any fashion, or make any representation or promise on behalf of Amity.
6. **Dispute Resolution.** Any controversy or claim arising out of or relating to this Warranty must be settled by arbitration in Fargo, North Dakota, at a time and location designated by the arbitrator, but not exceeding 30 days after a demand for arbitration has been made, and may be conducted by electronic, video, or other technical means. Arbitration will be conducted by the American Arbitration Association in accordance with its Rules of Commercial Arbitration, and judgment upon the award rendered by the arbitrator may be entered in any court having jurisdiction thereof. The arbitrator will have the authority to order Amity to undertake a repair or replace any Product, at its election, if the arbitrator finds that this Warranty requires Amity to do so. The arbitrator will not have the authority to impose any other remedy against Amity, including without limitation consequential or incidental damages, exemplary or punitive damages, or costs and fees.

• AMITY TECHNOLOGY, LLC • 2800 7TH AVENUE NORTH • FARGO, ND 58102 • e-mail address: info@amitytech.com •
(701) 232-4199 fax (701) 234-1716

Prices subject to change without notice

TABLE OF CONTENTS

Table of Contents	4
Congratulations!.....	6
Precautions	6
Features and Specifications.....	7
Air Cart	
Conversion Factors	
Formulas	
Mechanical Systems - Setup and Operation.....	8
Safety Railing / Ladder	
Product Bin Lids	
Auger	
Ground Drive	
Hydraulic Systems	
Blower	
Tires and Rims	
D3 System Overview	15
D3 System Hardware	
Product Bins and Meters - Setup and Operation.....	21
Setting Bin Fill Parameters	
Adjusting Product Meters	
Ground Drive Calibration and Operation	
Hydraulic Drive Calibration and Operation	
Mechanical Systems - Maintenance and Troubleshooting.....	28
Routine Maintenance	
Changing Metering Rolls - Ground Drive System	
Changing Metering Rolls - Hydraulic System	
Flute Options	
Other Meter Adjustments	
Gear Box	
Mechanical System Troubleshooting: Common Problems and Solutions	
Storage	

THIS PAGE
INTENSIONALLY
LEFT BLANK

CONGRATULATIONS!

Congratulations on your purchase of an Amity Technology Air Cart! Your Model 2800 or 3350 Air Cart has been designed to be durable, versatile, and simple to use.

Your Air Cart features stainless steel tanks and metering components, a streamlined and reliable meter system, a fill/unload auger with cupped poly lighting, and a world class ISOBUS-compatible monitoring and control system.

The following pages contain a wealth of important information on your Air Cart's features, equipment and systems. Read this manual carefully to learn how to set up, operate and use this equipment.

PRECAUTIONS

Safety First

The purpose of this manual is to assist you in safely operating and maintaining your Amity Technology equipment. It is the responsibility of the owner to ensure that anyone operating this equipment thoroughly reads and understands the information in this document.

It is not possible to overstate the importance of safety. Serious injury or death can result from improper operation of any farm equipment. We have taken great care to point out potential hazards that require special consideration.

Warning and Caution Symbols



This manual uses the following symbols to signify caution and warning. For your own safety take note of these symbols and exercise caution when working with this equipment.



Warnings

***ALWAYS** know your equipment. Read the owners manual before operating.*

***DO NOT** allow anyone to ride on the air system.*

***ALWAYS** install and transport stops when transporting the drill.*

***ALWAYS** use an adequate tow vehicle.*



***ALWAYS** remember to properly secure the safety chain.*

***DO NOT** Transport at speed greater than 20 MPH (32 KmPH).*

***DO NOT** modify or alter this equipment without first contacting Amity Technology, LLC.*

Caution

***ALWAYS** keep decals free of dirt and replace if they become damaged. See the parts section for proper placement.*



***ALWAYS** avoid high-pressure fluids. Use a piece of cardboard to search for suspected hydraulic leaks.*

FEATURES AND SPECIFICATIONS

Air Cart

Feature	AS2800	AS3350
Hopper Capacity	280 Bu (168 rear, 112 front)	335 bu (200 rear, 135 front)
Blower Drive	Hydraulic	Hydraulic
Meter Drive	Ground (optional Hydraulic)	Ground (optional Hydraulic)
Wheel Spacing	120" (36.6 m) front 150" (45.7 m) rear (120" rear optional)	120" (36.6 m) front 150" (45.7 m) rear (120" rear optional)
Tire Size	23.1 x 26 R1 - Standard (58.7 cm x 60 cm) 18.4 x 26 - Optional (46.7 cm x 60 cm)	23.1 x 26 R1 - Standard (58.7 cm x 60 cm) 18.4 x 26 - Optional (46.7 cm x 60 cm)
Fill/Unload Auger Cupped steel flighting (poly flighting optional)	8" x 18' (20.3 cm x 5.49 m)	10" x 21' (25.4 cm x 6.40 m)
Total height	12' 7" (3.84 m)	13' 5" (4.09 m)
Total length	27' (8.23 m)	27' (8.23 m)
Max width	14' 5" (4.39 m)	14' 5" (4.39 m)
Fill height	11' (3.35 m)	11' 10" (3.60 m)
Minimum ground clearance	19" (48.3 cm)	19" (48.3 cm)
Empty weight	8400 lbs (3810 kg)	8600 lbs (3900 kg)

Conversion Factors

1 Hectare = 2.47 Acres	1 lb = 0.45359 kg	1 bushel = 1.2445 cubic ft
1 acre = 43,560 square feet	1 lb = 16 oz	1 bushel = 0.0352 cubic meters
1 acre = .404 Hectares	1 kg = 35.3 oz	1 bushel = 9.31 gallons
1 inch = 2.54 cm	1 oz = 0.028 kg	1 PSI = 6.8948 kPa
1 foot = 0.3048 m	1 mph = 1.609 kph	1 GPM = 3.785 LPM
	1 mile = 1.609347 km	

Formulas

$$\text{Rate (lbs/min)} = \frac{\text{Width (ft)} * \text{Speed (mph)} * \text{Field Rate (lbs/acre)}}{495}$$

$$\text{Performance (acres/hr)} = \frac{\text{Width (ft)} * \text{Speed (mph)}}{8.25}$$

MECHANICAL SYSTEMS - SETUP AND OPERATION

Safety Railing / Ladder

Your Air Cart is equipped with a ladder and safety railings for access to the top of the tanks. Always make sure that the safety railings are secured in the raised position when operating the air system. The railings may be lowered for storage if required.

To lower the railings, remove the top bolt from each of the legs on the railing sections. Rotate the railing section down so that they hang beside the air system and reinsert the bolts in the holes for storage.



Caution

Do not lower the railings while standing on the catwalks. Use a suitable ladder and lower them from below. Always have the railings raised when working on top of the air system.



Safety railings

Product Bin Lids

The compartment lids on the air system compartments must be properly closed and sealed for the meters to deliver product properly.

Periodically check the lid for proper adjustment and inspect the seal for damage.

To determine whether the lid is adjusted properly, observe the lid when it is unlatched. It should incline slightly toward the latch end. A firm pull on the latch handle should be required to over-center the latch.

To adjust the hinge end of the lid, loosen or tighten the jam nuts on the hold down bar. (See photo)

To adjust the latch, loosen or tighten the nuts on the toggle u-bolt. (See photo)

In the off season, it is recommended that the latch be released to relieve pressure on the gasket.



Caution

If equipped with screen baskets, do not step or lean on the screens. They will not support a person's weight and may fall into the tank, resulting in injury.



Lid and latch with toggle u-bolt adjustment



Jam nuts on hold-down bar

Auger

Your Air Cart is equipped with an auger for loading and unloading the product bins. The auger is mounted on a swing arm that allows a flexible discharge hose to be moved to each compartment without moving the hopper. The swing arm also enables the auger to be turned around to unload and clean out the compartments.

The auger's hydraulic drive is supplied with oil from the blower hydraulics. A diverter valve above the blower directs oil to the auger. This may be switched with the blower running.

The auger also has a three position variable speed valve mounted on it to run the auger forward, backward or to stop.



Air cart with auger

Using the Auger to Load Products

The auger can be used to load and unload seed tanks. It can be adjusted on brackets to suit the operator's needs.

To place the auger in operating position:

1. Drop the front bracket lock pin just far enough to release the small pivot arm. (Unpin the long arm only to unload.)
2. Loosen the lock assembly. (Tee Handle)
3. Remove the auger from the rear clamp assembly.
4. Swing the hopper end of the auger away from the Air System and allow the short pivot arm to come out, away from the machine.
5. Place the hopper on the ground in a position perpendicular to the center line of the tanks with the discharge end of the auger between the compartment lids. From this position the discharge end of the auger should be able to be moved between compartments without moving the hopper.



Swing arm, bracket lock pin and small pivot arm



Air cart with auger in loading position

Using the Auger to Unload Products

1. Swing the large arm far enough away from the machine to allow the hopper to fit between the wheels.
2. Place the hopper under the meter for the compartment you wish to empty.



Placing the hopper under the meter

3. Close the metering slide.
4. Remove the product meter door.
5. Open the metering slide to control flow from the compartment.

Note

Removing the pointer allows the gate to be opened without changing the rate setting.



The meter with door removed

Cleaning Out the Auger

1. Tip the hopper upside down to empty.
2. Run the auger backwards until the auger tube is empty.



Hopper in the upright position

Ground Drive

On air carts equipped with ground drives a magnetic clutch allows the drive to be disengaged. The magnetic clutch uses electrical power to hold it engaged. The clutch is turned on and off by the D3 System either automatically when the drill is raised and lowered, or manually by pressing a manual Master Work Switch soft key on the virtual terminal in the tractor cab. The clutch requires no service.

When transporting long distances, remove the drive chain at the drive wheel. This will extend chain and sprocket life.

Note

Maximum recommended transport speed is 20 mph



Magnetic clutch

Hydraulic Systems

The hydraulic system on 2800/3350 air systems consists of a blower control circuit, an auger control circuit, and an optional Hydraulic drive control circuit. A combination of various control valves enables all three circuits to be powered by one hydraulic remote on the tractor. This system was designed to function under a maximum hydraulic pressure of 2900 psi.

Hydraulic Capacity

To run the hydraulic blower at the appropriate blower rpm., the tractor must have the following hydraulic capacities:

Blower RPM	Hydraulic Requirements (Ground Drive)	Hydraulic Requirements (Hydraulic drive)
5000	13 GPM at 1500 to 2200 PSI	18 GPM at 1500 to 2200 PSI
6000	16 GPM at 1700 to 2450 PSI	21 GPM at 1700 to 2450 PSI

Air System to Drill Hydraulic Couplers

The couplers connecting the air system to the drill/implement are 3/4 inch, high-flow couplers. Using 3/4 inch couplers reduces the pressure drop across the coupler and enables the operator to easily disconnect the air system from the drill.

The blower motor case drain line employs a 1/2 inch coupler. This smaller size ensures that it cannot be confused with the larger 3/4 inch couplers.

It is important to ensure that the pressure line on the tank is connected to the pressure line on the drill.



Hydraulic Couplers

Tractor to Blower Hydraulic Couplers

One-half (1/2) inch Pioneer tip couplers connect the blower pressure and return lines to the tractor.

A 3/8 inch flat-face coupler tip on the drill connects the case drain line to the tractor. This line must be connected or the blower motor will be damaged. If a case drain return port is not available on your tractor, contact your dealer for assistance in determining how to connect this line to the tractor's hydraulic reservoir.

A 3/4 inch low-pressure return tip is included with all Amity implements. It is also available through Amity Service Parts. If your tractor has a low-pressure port available, this tip can be used on the 3/4 inch blower return line to eliminate the pressure drop caused by the 1/2 inch Pioneer tip and the tractor's hydraulic valve on the return side. This tip can also be used on the case drain line, if the 3/8 inch flat face port is not available and the 3/4 inch low pressure return port is.

Do not install a tee connecting the blower return line and the blower case lines together. The blower case line must always be connected to a direct return to the hydraulic reservoir or blower motor failure will result.

The hydraulic line marked *Pressure* must be used to operate the blower. A check valve is installed in the blower circuit to protect the motor from an accidental pressurization of the return line.

Note

The 3/4 inch low pressure return tip is not compatible with the 3/4 inch high flow fittings used at the front of the cart. They look similar, but they are not compatible.



Tractor Hydraulic Connections (1)



Tractor Hydraulic Connections (2)

Hydraulic Drive

Air systems equipped with the hydraulic option use electric-over-hydraulic (EOH) technology to control the meter speed independently of ground speed. This gives the operator the benefit of a faster calibration procedure and on-the-go rate changing capability as well as the potential to apply product to a prescription map using GPS.

The hydraulic control valve diverts 5 GPM of hydraulic fluid flow from the fan circuit to power the variable rate drive motors. An electro-proportional flow-control valve controls the speed of each motor, allowing the meters to turn at speeds completely independent of each other.



Hydraulic Control Valve

The hydraulic drive motors mount to the meter housing and provide a direct drive of the meter shaft. The motor has a built-in speed sensor to provide accurate meter speed feedback to the electronics system.



Hydraulic Drive Motor

Blower

The air cart's blower system generates air pressure/flow to carry the seed or other input products through the system to the implement. The blower is driven by a hydraulic motor.

Two 3/4" hydraulic lines supply oil to the blower. A check valve is used on the return line to protect the system from running backwards. The hydraulic motor on the blower also has an internal check valve to prevent motor cavitation during shut down.

A third smaller (1/2") line connected to the blower motor is a case drain line. It is imperative that this is connected to a line directly to the tractor reservoir. Back pressure on this line will cause the shaft seal on the motor to fail. It is recommended that a female connector is used on this line at the tractor connection so that this line cannot accidentally be connected to pressure.

The only serviceable part on the blower is the shaft seal. This may be replaced if the motor leaks at the shaft. Do not disassemble the motor to replace the shaft seal. It is secured by a snap ring and can be removed with a seal pick.

A diverter valve above the blower selects either the fan or auxiliary (auger and/or winch) function. Push the knob in to run the blower. Pull the knob out to run the auger or winch.



The blower and associated hydraulics



Caution

Be sure that the case drain line on the blower motor is not connected to pressure. Damage to the shaft seal or motor will result.



Warning

Do not under any circumstances disassemble the motor. It is very difficult to assemble correctly and motor destruction will result from running an incorrectly assembled motor.

Note

Switch off fan to switch to auger.

Setting Blower Speed

The blower should be operated at as slow a speed as possible to prevent damage to seed. If operated too slowly, line blockage will occur. Typical blower speeds are between 3800 and 6000 RPM. Drill width, product, rate, humidity and other factors affect blower speed.

One method to determine blower RPM is to remove a final run from the seed boot or shoe. Hold the hose about 5 feet off of the ground pointing straight up. Turn product out of the meter with the blower running. The product coming from the hose should blow out of the hose about 8 inches into the air. Adjust blower RPM accordingly.

If you do not have a run blockage monitor, carefully watch to see that all runs are operating after changing blower speeds. To check runs, turn meter(s) with blower running and look to see that there is product at each ground opener.



Note

The number of outlets on the drill will directly affect the blower rpm. The more outlets in use, the higher the pressure required to maintain blower rpm. See your dealer for hydraulic adjustments to your tractor, if necessary.

Note

A diverter valve (2) above the blower selects fan or auxiliary (auger and/or winch) function. Push the knob in to run the blower. Pull the knob out to run the auger or winch.

Warning



Do not under any circumstances disassemble the motor. It is very difficult to assemble correctly and motor destruction will result from running an incorrectly assembled motor.

Tires and Rims

Inflate tires to the pressure indicated in the adjacent table. Torque lug nuts to 140 ft/lbs and retighten after the first 10 hours of operation.



CAUTION!



TIRE PRESSURES

Tire Size	Tire Ply	Tire Pressure
18.4 X 26.0	10	26 (MAX)
23.1 X 26.0	8	16 (MAX)
23.1 X 26.0	10	20 (MAX)



Caution!

Maximum speed of the air system is 20 mph.

D3 SYSTEM OVERVIEW

Your Air Cart utilizes a state-of-the-art electronic system to monitor and control the air cart's functions. The D3 ISO Monitor system is based on the ISO 11783 standard, often also referred to as ISOBUS. ISOBUS is a communications standard that enables a variety of agricultural electronics systems to talk to each other. Its purpose is to integrate all current and future farm functions by standardizing communication between tractor and implement. ISOBUS permits the use of the same tractor terminal on a number of different machines and hence control of a wide range of implements without the need to reprogram a system.

D3 System Hardware

The D3 ISO System includes a D3 electronic control unit (ECU), which connects to a variety of sensors and an electric-over-hydraulic (EOH) meter drive system. The ECU communicates with a virtual terminal (VT) located inside the tractor cab. The VT displays information and enables you to configure, calibrate and operate multiple systems from a single user interface.

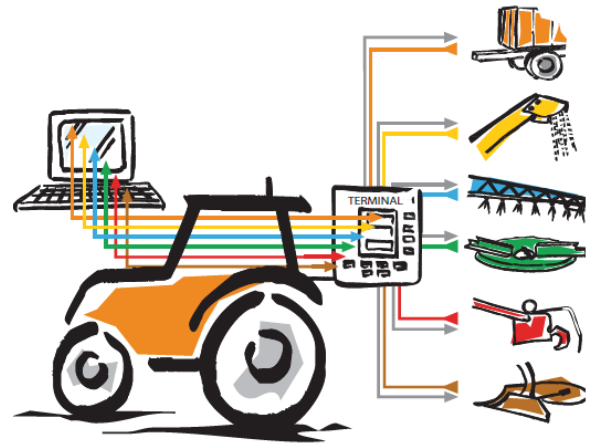

D3 Electronic Control Unit

The ECU is mounted on the air system. It monitors all system sensors and controls the meter drives. The ECU connects to the VT in the tractor cab via an interconnecting cable that plugs into the front of the ECU on one end and into the standard ISOBUS connector on the tractor at the other end.



D3 ECU

Virtual Terminal

The VT in the tractor cab provides a user interface for the system, communicating with the D3 ECU and (any other ISOBUS-compatible equipment you may add to your equipment). Your VT could be the Amity-supplied VT, the tractor's OEM VT, or any other ISOBUS-compatible VT.

Several companies manufacture ISOBUS-compatible virtual terminals. All terminals use the same screen icons to represent the main functions. The control screens, or pages, for the implement (which are displayed in the central area of the screen) are identical for any ISOBUS-compatible terminal.

Currently the following virtual terminals can be used with your ISO Drill Manager system:

- GTA Console 1 and Console 2 (AGCO)
- AFS Pro 600 & Pro 700 (Case IH)
- GreenStar2 & GreenStar3 (John Deere)
- IntelliView II IntelliView Plus II (New Holland)
- IntelliAg (DICKEY-john)
- LH6000 (TeeJet)



C1000

Blower Speed Sensor

An inductive sensor on the blower fan provides speed information to the ECU.



Bin Level Sensor

Optical bin sensors indicate when the level of product in the bin has decreased to the level of the sensor. The same sensor detects all types of products. The sensor height can be adjusted vertically to set the alarm point at any desired level.



Meter Box Flow Sensor

A capacitive sensor detects when the meter box is empty. This indicates if the bin is completely empty, or if the product has stopped flowing into the meter box because of bridging or a leaky lid on the bin.



Meter Shaft Speed Sensor (Ground Drive)

A magnetic proximity sensor is used to detect the speed of the meter shaft. This information is used to calculate how much product has been applied and also indicate that the ground drive system is function properly.



Meter Shaft Speed Sensor (Variable Rate)

If the air system was purchased with the variable rate option, an integral speed sensor is provided with the hydraulic motor. This sensor is very accurate and provides the precise meter speed control that is needed.



Ground Speed Sensor

This unit is equipped with a GPS speed sensor. This is used for speed sensing only and cannot be used for mapping.



PLEASE REFERENCE
ISO MANUAL
FOR MONITOR OPERATION



2012 Cart Control System

Operators Manual



Adjusting Product Meters

The product meters deliver seed or fertilizer from the product bins to the air stream via a fluted roller. The amount of the roller that is being used determines the rate at which products are applied.

There are two moveable components in the meter that determine the rate setting.

The primary setting is a flow plate adjusted by a rod connected to a pointer. When a rate setting is selected, the pointer is simply placed at that number on the rate decal. A lock bolt on the pointer rod secures the setting.

The second part of the adjustment is the meter shut off slide. For any rate setting the proper place for shut off slide is against the stop on the pointer. This opens the bottom of the tank compartment the proper amount for the rate setting. A ½" drive ratchet supplied in the toolbox is used to adjust the meter shut off slide.

Any time that a new rate is set, the rate setting should be confirmed by calibrating the meter.

A scale and catch bag are supplied in the tool box for calibration.

Once a rate setting is determined from the rate charts and the meter is set to that setting, perform the following calibration procedures.

When using both tanks for one product, determine the rate for each meter by splitting the desired rate by the ratio of the tanks (60/40). This will result in both tanks emptying at the same time.

Example

If you desire to seed 120 lbs. of wheat using both meters, split the desired **pounds per acre** rate to the ratio of the size of the tanks. i.e. If the Air System is a 60/40 split, set one meter to 72 lbs. (120 x.6) and the other meter to 48 lbs. (120 x.4)

Note

When decreasing the meter setting, it may be necessary to close the shutoff slide and turn the meter to empty it. This will empty the meter and allow the plate to move to a smaller setting.

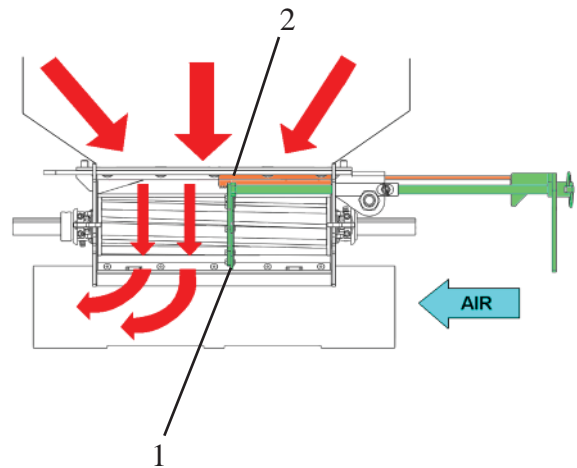
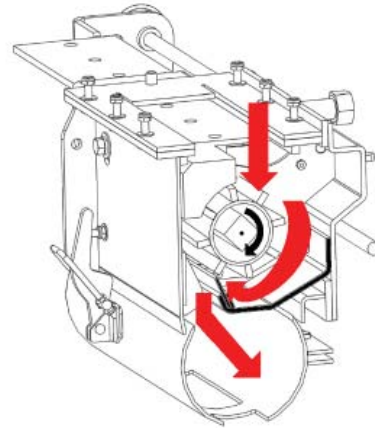

Note

Plate (1) controls how much of meter roller will be used. The shut off slide (2) is opened to the stop on the pointer for any rate setting. When making large rate reductions, close the slide and empty the meter to allow the plate to move to the lower setting. Remember to reopen the slide until it contacts the stop on the pointer.

Ground Drive (GD) Calibration and Operation

If you have a ground drive (GD) system, calibration involves deciding on a fixed target application rate (lbs/acre) and then setting up the meter mechanically to deliver that rate. The ground drive system compensates for speed changes by varying the meter speed to keep application rate uniform. The calibration procedure also includes entering several pieces of information into the D3 System to ensure accurate indications and to avoid nuisance alarms.

Setting up the Application Rate on a GD System

To set up and operate the ground drive:

1. Determine your desired target application rate.
2. Set the pointer on the product meter to your desired target rate setting.
3. Secure the setting by tightening the bolt to lock the pointer rod.
4. Use the ratchet supplied to open the shut off slide until it contacts the stop on the pointer.
5. Hang the calibration bag on the scale and zero the scale so the weight of the bag will not compromise the accuracy of the measurement.
6. Open the clean out door under the air tube by releasing the toggle clamps.
7. Turn the crank at the front of the Air System one complete revolution to prime the meter.
8. Hang the calibration bag on the meter tube so that the clean out door is inside of the bag and the bag is under the openings in the bottom of the air tube.
9. Using the table on the right side of this page, determine the number of turns required to cover 1/10 of an acre.
10. Manually crank the meter the required number of turns.
11. Remove the bag and weigh it on the scale. Multiply the weight times 10 to get the rate per acre.
12. Adjust the meter to a higher or lower setting and repeat the procedure until the desired rate is set.

Seed Rate Setting Tips

- *When setting a rate for a small amount per acre such as canola or sunflowers, calibrate with more than 1/10 of an acre amount of turns. Turn out a complete acre for rates less than a 10 lb. rate*
- *Recalibrate rates after seeding a partial tank.*
- *Remember to “prime the meter” by turning the crank before calibrating.*
- *Remember to zero the scale with the empty bag on it before calibrating.*
- *Close meter shut off slide on compartment not being calibrated.*

Note

Look up the rate setting for each tank separately in the appropriate rate chart.

Implement Width ft (m)	Turns (of crank) per Acre (Ha) 10T & 23.1R26	Turns (of crank) per acre (Ha) 15T&23.1R26 17T&18.4R26
30 (9.1)	189 (467)	126 (311)
32 (9.8)	179 (441)	119 (294)
34 (10.4)	168 (415)	112 (277)
36 (11.0)	159 (393)	106 (262)
38 (11.6)	150 (371)	100 (247)
40 (12.2)	143 (352)	95 (235)
42 (12.8)	135 (334)	90 (222)
44 (13.4)	129 (319)	86 (213)
45 (13.7)	128 (315)	85 (210)
46 (14.0)	125 (308)	83 (205)
48 (14.6)	119 (293)	79 (195)
50 (15.2)	114 (282)	76 (188)
52 (15.8)	110 (271)	73 (180)
54 (16.5)	105 (259)	70 (173)
56 (17.1)	102 (252)	68 (168)
58 (17.7)	99 (245)	66 (163)
60 (18.3)	95 (234)	63 (156)

Note

The data in the above table is based on using either of the following:

- *17 tooth gearbox sprocket with 18.4R26 tires*
- *15 tooth gearbox sprocket with 23.1R26 tires*

Hydraulic Drive Calibration and Operation

Calibration is done in four parts. First, you must prepare the system for calibration. Second, you prime the meter. Third, you take a sample and weigh it. Finally, you enter the sample, or Accumulated weight into the virtual terminal.

Preparing to Calibrate the Meter

Hydraulic power is needed for calibration. The following procedure sets up the air system for the calibration procedure.

1. Ensure that the air system's hydraulic lines are connected to a tractor.
2. Verify that the tractor hydraulic remote for the blower is in neutral until hydraulic power is needed.
3. Ensure that the monitor wire harness is properly connected to the tractor.
4. Power up the monitor in the tractor.
5. Verify that the VT in the cab is communicating with the Air System ECU.
6. Ensure that the meter door is properly attached to the meter.
7. Ensure the bin is at least 25% full of the product that will be applied.
8. Set the meter gate to the appropriate position for the rate being applied.
9. Ensure the auger selector valve is directing oil to the fan/meter circuit.
10. Close the blower ball-valve.
11. Actuate the tractor remote controlling the blower circuit.
12. Make sure the blower is not spinning for the following steps. If the blower is spinning, check the ball valve to make sure that it is full closed and blocking all flow to the blower..
13. Open the cleanout door below the meter you wish to calibrate.



The Auger Selector Valve



Adjusting the Meter Gate

The meter must be calibrated if:

- *The gate setting has been changed*
- *A different product is being used*
- *A different meter roll is being used*

Each meter must be calibrated individually, even if all the gates are set the same.

Meter Gate Setting Guide – Hydraulic Drive - High Capacity Meter Roll				
Rate lbs/ac <i>(kg/Ha)</i>	30 ft <i>(9m)</i>	40 ft <i>(12m)</i>	50 ft <i>(15m)</i>	60 ft <i>(18m)</i>
50 <i>(56)</i>	3" <i>(76 mm)</i>	4" <i>(102 mm)</i>	5" <i>(127 mm)</i>	6" <i>(152 mm)</i>
100 <i>(112)</i>	4" <i>(102 mm)</i>	6" <i>(152 mm)</i>	8" <i>(203 mm)</i>	10" <i>(254 mm)</i>
150 <i>(168)</i>	6" <i>(152 mm)</i>	8" <i>(203 mm)</i>	10" <i>(254 mm)</i>	Max
200 <i>(224)</i>	8" <i>(203 mm)</i>	10" <i>(254 mm)</i>	Max	Max

Priming the Meter

To ensure accurate calibration, the meter must be primed with product.

1. On the ECU keypad, locate the button with the number corresponding to the meter you are calibrating. This is called the ECU Calibration button.
2. Press the ECU Calibration button once.
The meter roll begins spinning.
3. Allow the meter to spin 2 to 3 revolutions to ensure that the meter is full of product.
4. Press the same button again to stop the meter.
The meter is now primed.

Note

Each time the calibration button on the ECU is pressed to activate the meter the ECU counts the revolutions of the meter roll. This count is reset each time this process is performed. Once you stop the meter roll, the bag must be weighed. If you did not collect enough product in the bag to obtain a measurable weight, you must dump the bag and start over with an empty bag.

Taking a Sample for Calibration

1. Using the weigh scale included with your system, hang the calibration bag (also included) on the scale and zero out the weight of the bag.
2. Place the calibration bag below the cleanout opening.
Be careful to ensure all product will flow into the bag.
3. Press the ECU Calibrate button to activate the meter.
4. Allow the meter to spin until the bag is at least half full.
5. Press the ECU Calibrate button again to stop the meter.
6. Weigh the bag with the supplied scale.
This value is the Accumulated Weight value you will enter into the VT.

Note

Do not press the ECU Calibrate button again until the Accumulated weight is entered into the VT. Pressing the ECU Calibrate button before the weight is entered will clear the rotation counter and void the sample.

7. Repeat the previous steps to obtain sample weights for the rest of the meters.
8. When all the weights have been found, go back to the tractor and enter the calibration weights into the Product page on the Virtual Terminal.



Note

To calibrate a product meter it must be enabled (active) on its Product page (I).



Entering Accumulated Weight on the VT

1. On the Home page, press the soft key for the desired bin.
The Product page for the selected bin appears
2. On the Product page, select Accum (lbs).
3. Enter the accumulated weight value obtained in the meter calibration procedure in pounds.

Repeat Steps 1 to 3 for each additional bin.

Note

Once you enter the Accum value the monitor automatically calculates the Motor Cal value. The Motor Cal value is the number of pounds (lbs) of product applied per revolution of the meter roller. E.g. If the Motor Cal value is 1.2, The meter will deliver 1.2 lbs of material during each revolution of the meter roll.

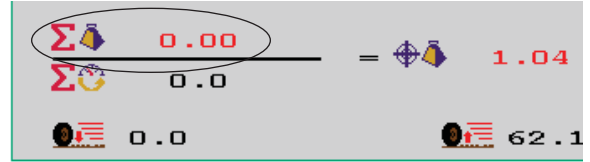

What is Min and Max Speed?

After the Accum value has been entered, the D3 System calculates the Min Speed and Max Speed values (in mph). These values define the range of speeds you can travel while maintaining accurate application per acre. During planting, if you travel at a speed less than the minimum or greater than the maximum your application accuracy will be compromised.

Manually setting Motor Cal Value for a VR system

Set the Motor Cal value in the D3 System as follows:

1. On the VT, navigate to the Product page.
2. Select Motor Cal.
3. Enter the desired Motor Cal value.

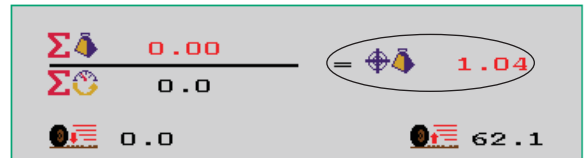

THIS PAGE
INTENTIONALLY
LEFT BLANK

WHEAT

High Capacity Flute P/N 65705
1/4" WIDE X 1/2" DEEP BARS

GROUND DRIVE ONLY
17T GEAR BOX SPROCKET W/ 18.4 R26 TIRES
15T GEAR BOX SPROCKET W/ 23.1 R26 TIRES

WIDTH (FT)	APPLICATION RATE (LBS PER ACRE)																		
	60	70	80	90	100	110	120	130	140	150	160	170	180	190	200	210	220	230	240
20	2.7	3.1	3.6	4.0	4.5	5.0	5.4	5.8	6.3	6.7	7.2	7.6	8.1	8.5	8.9	9.4	9.8	10.3	10.8
25	3.4	3.9	4.5	5.0	5.6	6.2	6.8	7.3	7.8	8.4	8.9	9.5	10.1	10.6	11.2	11.8	12.3	12.9	13.4
30	4.1	4.7	5.4	6.0	6.8	7.4	8.1	8.8	9.4	10.1	10.7	11.4	12.1	12.8	13.4				
35	4.7	5.5	6.3	7.0	7.9	8.7	9.5	10.2	10.9	11.7	12.5	13.3							
40	5.4	6.3	7.2	8.0	9.0	9.9	10.8	11.7	12.5	13.4									
45	6.1	7.1	8.1	9.0	10.1	11.1	12.2	13.2											
50	6.8	7.9	9.0	10.0	11.3	12.4	13.5												
55	7.4	8.7	9.9	11.0	12.4	13.6													
60	8.1	9.4	10.8	12.0	13.5														

APPROXIMATE POINTER SETTING

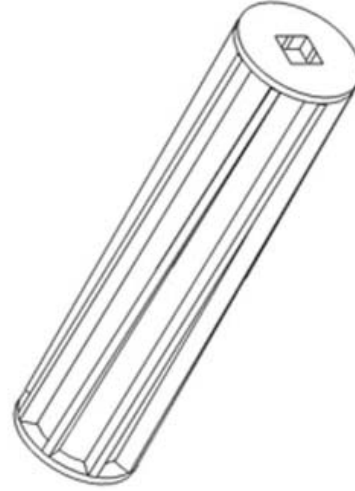
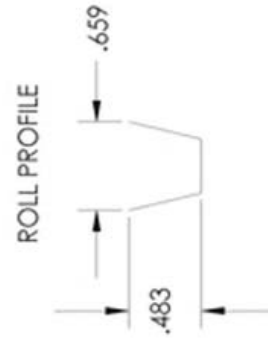

FERTILIZER (60 LBS PER CUBIC FT.)

High Capacity Flute P/N 65705
 1/4" WIDE X 1/2" DEEP BARS

GROUND DRIVE ONLY
 17T GEAR BOX SPROCKET W/ 18.4 R26 TIRES
 15T GEAR BOX SPROCKET W/ 23.1 R26 TIRES

WIDTH (FT)	APPLICATION RATE (LBS PER ACRE)																		
	60	70	80	90	100	110	120	130	140	150	160	170	180	190	200	210	220	230	240
20	2.3	2.7	3.1	3.5	3.8	4.2	4.6	5.0	5.4	5.8	6.1	6.5	6.9	7.3	7.7	8.1	8.4	8.8	9.2
25	2.9	3.4	3.8	4.3	4.8	5.3	5.8	6.2	6.7	7.2	7.7	8.2	8.6	9.1	9.6	10.1	10.6	11.0	11.5
30	3.5	4.0	4.6	5.2	5.8	6.3	6.9	7.5	8.1	8.6	9.2	9.8	10.4	10.9	11.5	12.1	12.7	13.2	13.8
35	4.0	4.7	5.4	6.0	6.7	7.4	8.1	8.7	9.4	10.1	10.8	11.4	12.1	12.8	13.4				
40	4.6	5.4	6.1	6.9	7.7	8.4	9.2	10.0	10.8	11.5	12.3	13.1	13.8						
45	5.2	6.0	6.9	7.8	8.6	9.5	10.4	11.2	12.1	13.0	13.8								
50	5.8	6.7	7.7	8.6	9.6	10.6	11.5	12.5	13.4										
55	6.3	7.4	8.4	9.5	10.6	11.6	12.7	13.7											
60	6.9	8.1	9.2	10.4	11.5	12.7	13.8												

APPROXIMATE POINTER SETTING

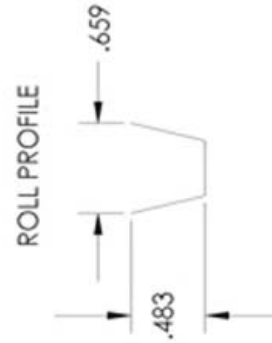
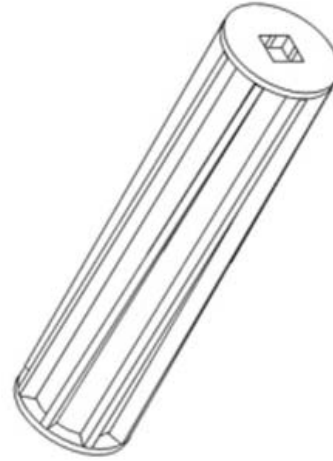

SOYBEANS

High Capacity Flute P/N 65705
1/4" WIDE X 1/2" DEEP BARS

GROUND DRIVE ONLY
17T GEAR BOX SPROCKET W/ 18.4 R26 TIRES
15T GEAR BOX SPROCKET W/ 23.1 R26 TIRES

WIDTH (FT)	APPLICATION RATE (LBS PER ACRE)																		
	60	70	80	90	100	110	120	130	140	150	160	170	180	190	200	210	220	230	240
20	3.1	3.6	4.1	4.6	5.2	5.7	6.2	6.7	7.2	7.7	8.2	8.8	9.3	9.8	10.4	10.9	11.4	11.9	12.4
25	3.9	4.5	5.2	5.8	6.4	7.1	7.8	8.4	9.0	9.6	10.3	10.9	11.6	12.2	12.9	13.6			
30	4.7	5.4	6.2	6.9	7.7	8.6	9.3	10.1	10.8	11.6	12.3	13.1	13.9						
35	5.4	6.3	7.2	8.0	9.0	10.0	10.9	11.7	12.6	13.5									
40	6.2	7.2	8.3	9.2	10.3	11.4	12.4	13.4											
45	7.0	8.1	9.3	10.4	11.6	12.8	14.0												
50	7.8	9.1	10.3	11.5	12.9	14.0													
55	8.5	10.0	11.4	12.6	14.2														
60	9.3	10.9	12.4	13.8															

APPROXIMATE POINTER SETTING

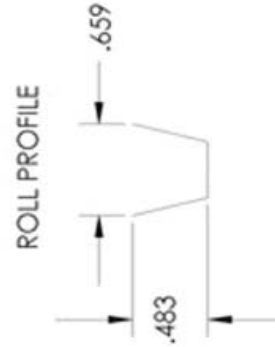
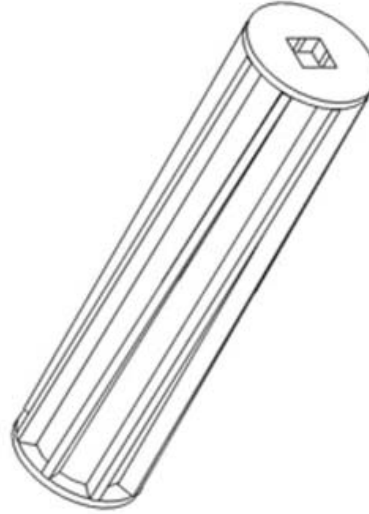

BARLEY

High Capacity Flute P/N 65705
1/4" WIDE X 1/2" DEEP BARS

GROUND DRIVE ONLY
17T GEAR BOX SPROCKET W/ 18.4 R26 TIRES
15T GEAR BOX SPROCKET W/ 23.1 R26 TIRES

APPLICATION RATE (LBS PER ACRE)

WIDTH (FT)	APPLICATION RATE (LBS PER ACRE)																		
	60	70	80	90	100	110	120	130	140	150	160	170	180	190	200	210	220	230	240
20	3.4	3.9	4.5	5.0	5.6	6.2	6.7	7.3	7.8	8.4	8.9	9.5	10.1	10.7	11.2	11.8	12.3	12.9	13.4
25	4.2	4.9	5.6	6.3	7.0	7.7	8.4	9.1	9.8	10.5	11.2	11.9	12.6	13.3					
30	5	5.8	6.7	7.6	8.4	9.2	10.1	10.9	11.8	12.6	13.4								
35	5.9	6.8	7.8	8.8	9.8	10.8	11.7	12.8	13.7										
40	6.7	7.8	8.9	10.1	11.2	12.3	13.4												
45	7.5	7.0	10.0	11.4	12.6	13.8													
50	8.4	9.8	11.1	12.6	14.0														
55	9.2	10.7	12.2	13.9															
60	10.1	11.7	13.4																

APPROXIMATE POINTER SETTING

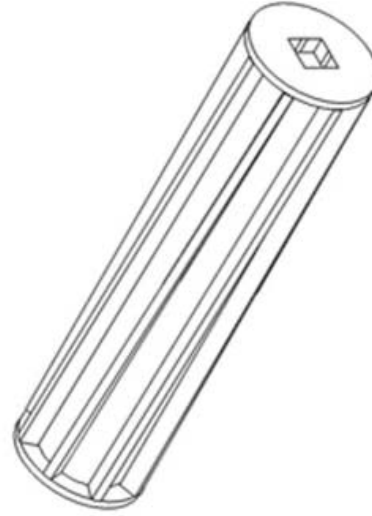

ROLL PROFILE



MECHANICAL SYSTEMS - MAINTENANCE AND TROUBLESHOOTING

Routine Maintenance

Drive Line and Steering

Lubricate all drive line bearings and steering components every 50 hours with a SAE multipurpose grease.

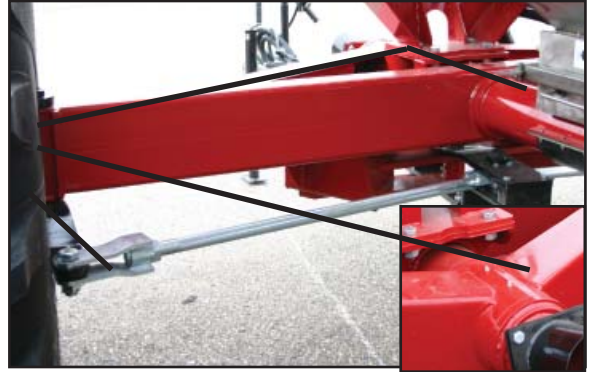

Gear Box

The gear box is filled at the factory and requires no maintenance. Service is required only if oil leaks become visible.



Hydraulic Motor

The hydraulic motor can only be damaged by heat or foreign material. Keep your tractor hydraulic oil and filter serviced regularly to ensure long life from your hydraulic components.



Wheel Bearings

Annually check wheel bearings for tightness. Adjust if needed. Repack every three (3) years.



Changing Metering Rolls - Ground Drive System

To change metering rolls on a GD System:

1. Close the meter gate or ensure the bin is empty.
2. Remove the meter door and set aside.
3. Remove the chain from the meter drive sprocket. Do not remove the sprocket.
4. Remove the two nuts that hold the bearing on the meter shaft (sprocket end only).
5. Pull the shaft out of the meter while holding on to the meter roll.
6. Remove the meter roll.
7. Re-assemble the meter in reverse order with the desired flute.

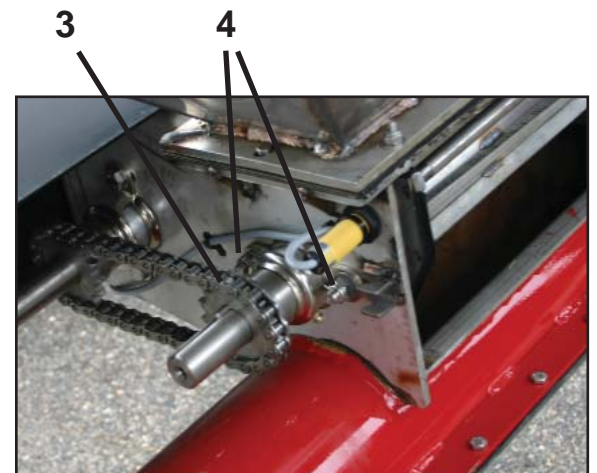

Changing Metering Rolls - Hydraulic System

To change metering rolls on a Hydraulic System:

1. Close the meter gate or ensure the bin is empty.
2. Remove the meter door and set aside.
3. Remove the (2) ½" bolts holding the hydraulic motor to the motor mount.
4. Remove the two nuts that hold the bearing on the meter shaft (motor-end only).
5. Pull the shaft out of the meter (with the motor still attached) while holding on to the meter roll.
6. Remove the meter roll.
7. Re-assemble the meter in reverse order with the desired meter roll.



Meter Roll Options

Amity's standard high capacity and optional medium capacity meter rollers are constructed of stainless steel for lifetime performance

Four meter roll options are available.

The high capacity roll has eight ½" deep bars and is used for most applications.

The medium capacity roll has twelve ¼" deep bars and is used on smaller machines or for consistently lower seeding or fertilizer rates.

The low volume has a pattern of short, shallow depressions to gradually larger, deeper depressions for very low seeding rate.

The fine product meter roll has a continuous pattern of shallow depressions for very low seeding rates with high accuracy.

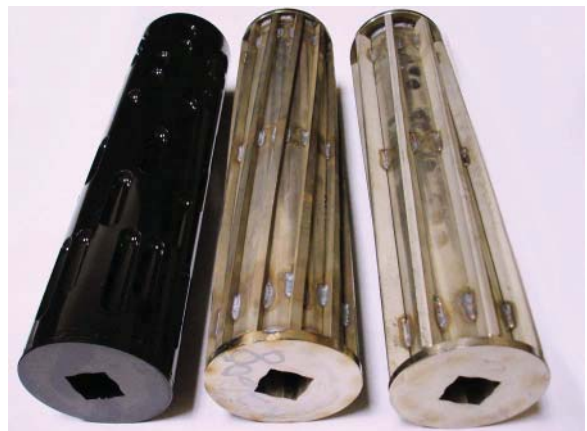

Other Meter Adjustments

The following adjustments are done at the factory and should only be done by a trained service technician.

Shims

- The meter roll should have a small gap (.030") between the roll and the meter housing for proper operation. If the gap is too large product can leak around the meter roll into the air stream. If the gap is too tight the meter roll will bind on the housing and cause problems with the meter drive system.
- A .030" thick shim (Amity P/N 65744) can be installed between the meter roll and the meter housing to reduce this gap. The meter shaft needs to be removed to install this shim, see the section on changing meter rolls on the procedure to remove the shaft.
- Ensure the meter roll turns freely after installing or removing any shims. If the meter roll does not turn freely, DO NOT operate the air system until enough shims have been removed to allow the meter roll to turn freely.

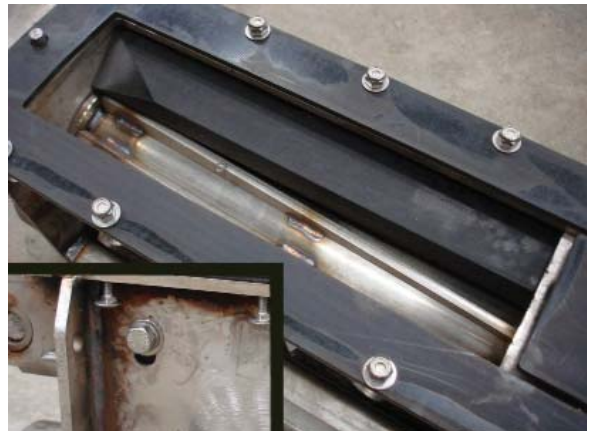

Deflector Block

The black plastic deflector block in the rear of the meter prevents seed from flowing around the back side of the meter roll. If needed, this block can be adjusted vertically to increase or decrease the clearance to the meter roll. To adjust, loosen the two nuts on the back side of the meter housing, move the block to the desired position, and tighten the nuts to lock the block into place.

Meter Door and Cleanout Door Latches

The tension on these latches can be adjusted to increase or decrease the preload on the meter door and the cleanout door. If the preload is too small, the doors will not seal properly. If the tension is too tight, the latches will be difficult to close. The tension can be adjusted by unlocking the latch and screwing the two stop-nuts evenly in or out. Ensure the door preload is adequate before putting the unit back into service.



Meter Door Tray

The tray on the meter door can be adjusted vertically in order to increase or decrease the tension between the rubber seal on the tray and the meter roll. To adjust, loosen the two nuts holding the tray to the meter door, move the tray to the desired position, and tighten the nuts to lock the tray into place.



Gear Box

The gear box is filled with oil at the factory and does not require service. If a visible leak appears at one of the seals, repair the box and fill half-full with 85W90 oil (Amity P/N: 330132).

The drive line components are protected by a shear pin located on the gearbox coupler. If the pin fails, determine the reason for the failure, remove, and install a new shear pin.

To replace the shear pin:

1. Loosen the bolt on the locking tab and rotate the tab out of the machined groove in the shear pin.
2. Remove any broken shear pin pieces and line up the holes in the coupler with the hole in the shaft.
3. Install a new shear pin.
4. Rotate the lock tab into the machined groove on the shear pin and tighten the bolt on the tab.



Gear box



Gear box shear pin

Mechanical Systems Troubleshooting: Common Problems and Solutions

Symptom	What it means	Recommended Action
Seed cups will not engage	Shear pin may have broken	Clear obstruction and replace pin.
	Clutch has no power going to it	Be sure there is power to clutch using test light.
	Clutch may have failed	Replace clutch.
Seed cups will not disengage	Sprocket on clutch may have frozen shaft	Check plastic bearing under sprocket.
	Short in monitor is supplying power to the clutch.	Find short and repair.
Seed is flowing without cups turning. (A small amount of seed flow is normal and not a cause for concern.)	Rubber deflector is not down tightly on flute.	Lower the deflector.
	Rubber wiper on seed cup door damaged or not up tightly against flute.	Raise door or replace rubber wiper if damaged.
	Product is building up in air delivery system.	Increase blower speed.
Excessive seed cracking is occurring	Air stream velocity is too great.	Reduce blower speed or adjust blower baffle on dual air stream machines.
Seed boots are plugging	Turning corners too sharply with boots in the ground.	Always raise ground opener before making a sharp turn.
	Ground openers have been left in the ground when backing up.	Always raise ground opener before backing up.
Product distribution is uneven	A one inch hose may be plugged.	Re-route or cut 1" hoses to eliminate sags. Clear any obstruction in hoses or boots.
Uneven delivery rate	Loss of tank pressure.	Check tank lids for leaks. Inspect and replace faulty gaskets.
Oil showing up on seed lines	Shaft seal failure on hydraulic motor.	Replace seal. WARNING: DO NOT DISASSEMBLE HYDRAULIC MOTOR!! THE SHAFT SEAL IS AN EXTERNAL REPLACEMENT ITEM.
Hydraulic motor slow	Monitor set to wrong blower speed setting (See Monitor Section).	See Monitor Section
	Tractor is not putting out adequate oil.	Have tractor dealer inspect tractor hydraulics.
	Bad couplers.	Check couplers on tractor and hoses. Try different couplers.

Storage

- Fully open the seed meters.
- Open clean out doors on the bottom of the air tube.
- Clean any remaining product from tanks.
- Use water to thoroughly clean any compartment used for fertilizer
- Thoroughly clean fertilizer and dirt from cup area.
- Clean the inside of the seed meter door. Fertilizer, seed and dirt accumulate in this area.
- Clean any remaining product from the auger and leave the auger slide open.
- Oil chains.
- Grease all lubrication points.
- Check the gear box for visible leaks. If none, no service is required.
- Release the latch on the tank lids to relieve pressure on the lid gaskets.

AIR SYSTEM ASSEMBLY PARTS

PARTS TABLE OF CONTENTS

PartsTable of Contents	37
Assy-Tank/Running Gear.....	38
Assy-Airstream Single	39
Assy-ECU	40
Assy-Pressurization Kit	42
Assy-Axles Front.....	43
Assy-Drawpole & Steering Linkage.....	44
Assy-Axles Rear	46
Assy-Tie Rod.....	47
Assy-Hub 65450 & 1017759	47
Assy-Meter Driveline	48
Assy-W&T 18.4x26 R1 8Ply, 16x26x8.....	50
Assy-W&T 23.1x26 R1 10Ply, 20x26x8.....	50
Kit-Calibration Components.....	51
Assy-Meterbox.....	52
Assy-Meterbox Door	54
Assy-Blower.....	56
Assy-Blower Hydraulics Ground Drive	58
Assy-Ground Drive.....	60
Assy-Blower Hydraulics Hydraulic Drive	62
Assy-Hydraulic Drive	64
Assy-Catwalk & Handrails	65
Assy-Ladder Air System	66
Assy-Auger & Hydraulics (8"/10").....	66
Assy-Auger Mounting Components (8"/10")	69
Assy-Doors	70
Assy-Decals Airs System	71

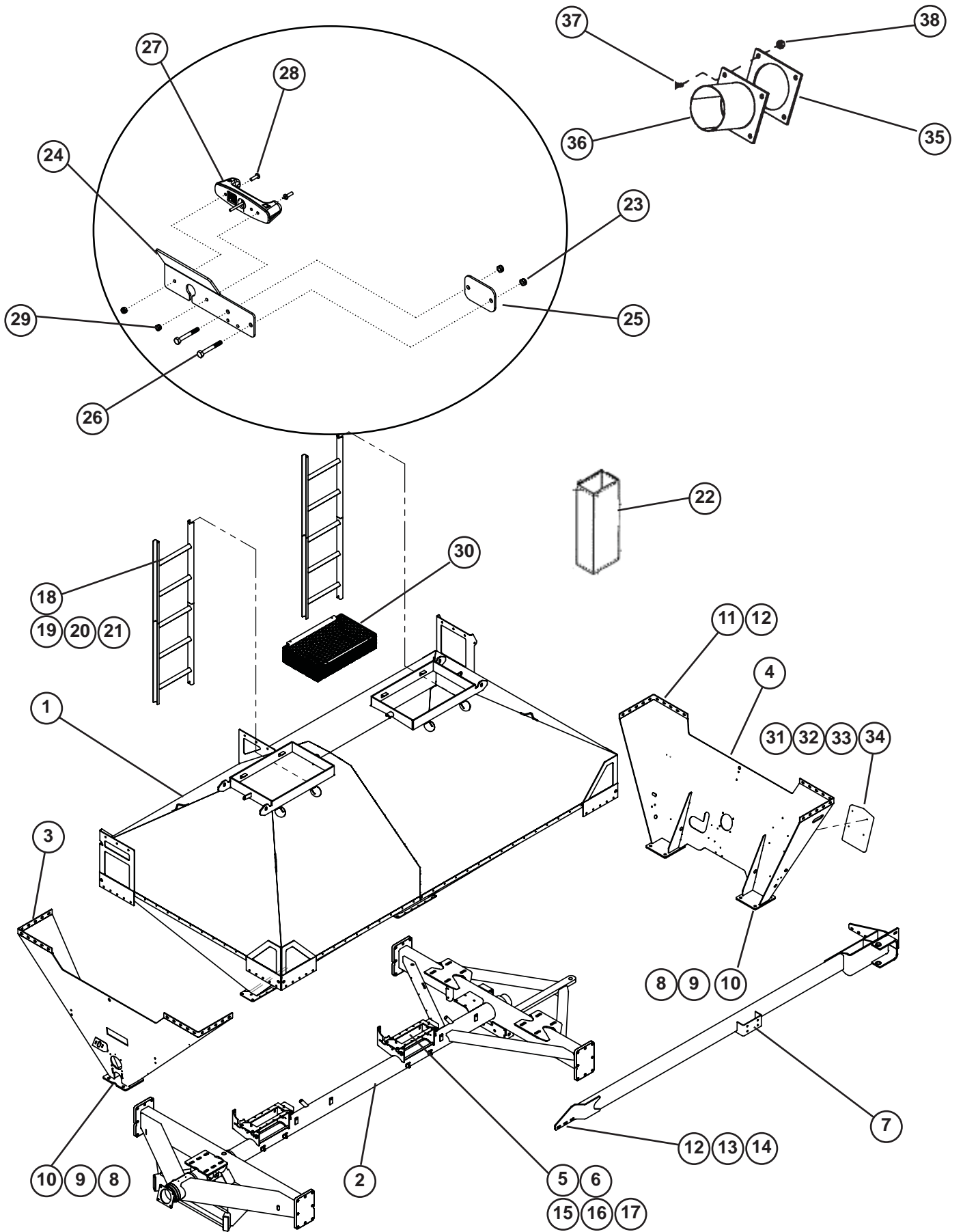

ASSY-TANK/RUNNING GEAR

Ref.	Part No.	Description	Qty.
1	65402	WLDMT-TANK 2800	1
	65938	WLDMT-TANK 3350	1
2	65406	WLDMT-RUNNING GEAR	1
3	65525	WLDMT-FRONT PANEL	1
4	65526	WLDMT-REAR PANEL	1
5	65512	GASKET-SEEDBOX .250	2
6	64504	SEALANT-PROGLAZE - OZ.	90
7	65816	WLDMT-AUGER MOUNT	1
8	1012060	BOLT-HEX: .75 X 2.00 NC GR5 ZP	14
9	1017000	NUT-TOPLOCK: .75 NC GR5 ZP	14
10	1030702	WASHER-FLAT: .75 ZP	14
11	1011606	BOLT-HEX: .50 X 1.25 NC GR5 ZP	29
12	1011608	BOLT-HEX: .50 X 1.75 NC GR5 ZP	11
13	1027461	NUT-TOPLOCK: .50 NC GR5 ZP	40
14	1011584	WASHER-FLAT: SAE .50 ZP	51
15	66043	BOLT-CRG: SS .250 X 1.25 NC	20
16	65695	WASHER-FLAT: .250 SS	20
17	1033269	NUT-NYLOCK: .25 NC GR2 SS	20
18	65678	WLDMT-LADDER INSIDE 2800	2
	65942	WLDMT-LADDER INSIDE 3350	2
19	1033271	BOLT-HEX: SS .38 X 1.00 NC	4
20	1033268	NUT-NYLOCK: .38 NC GR2 SS	4
21	65778	WASHER-FLAT: .375 SS	8
22	66549	KIT-LOW VOLUME TANK INSERT 2800 (OPTIONAL)	
	66550	KIT-LOW VOLUME TANK INSERT 3350 (OPTIONAL)	
22.1	34158	INSERT-LOW VOLUME 5800 (RED)	1
	66584	INSERT-LOW VOLUME 3350 (GREEN)	
22.2	66788	FRAME-LOW VOLUME INSERT	1
22.3	57109	NUT-COUPLER .50 X 1.75 ZP	1
22.4	1011591	NUT-JAM: .50 NC GR2 ZP	1
23	1033269	NUT-NYLOCK: .25 NC GR2	2
24	65836	MOUNT-BIN LEVEL SENSOR	1
25	65837	PLATE-BOLTING	1
26	65838	BOLT-HEX: SS .25 X 2.00 NC GR5	2
27	66509	BIN LEVEL SENSOR	1
28	65839	SCREW-P-H: #10 X .75 NC SS	2
29	65712	NUT-NYLOCK: #10-24 SS	2
30	1026562	SCREEN BASKET	2
31	64635	CASE-MANUAL STORAGE	1
32	1011595	BOLT-HEX: .25 X .75 NC GR5 ZP	4
33	1020416	WASHER-FLAT: .25 ZP	4
34	1030946	NUT-TOPLOCK: .25 NC GR5 ZP	4

ASSY-AIRSTREAM SINGLE

Ref.	Part No.	Description	Qty.
35	1023159	GASKET .13 X 5.75 X 7-5" ID	1
36	65443	WLDMT-FLANGE & TUBE	1
37	1011606	BOLT-HEX: .50 X 1.25 NC GR5 ZP	4
38	65313	NUT-NYLOCK: .50 NC GR2 ZP	4

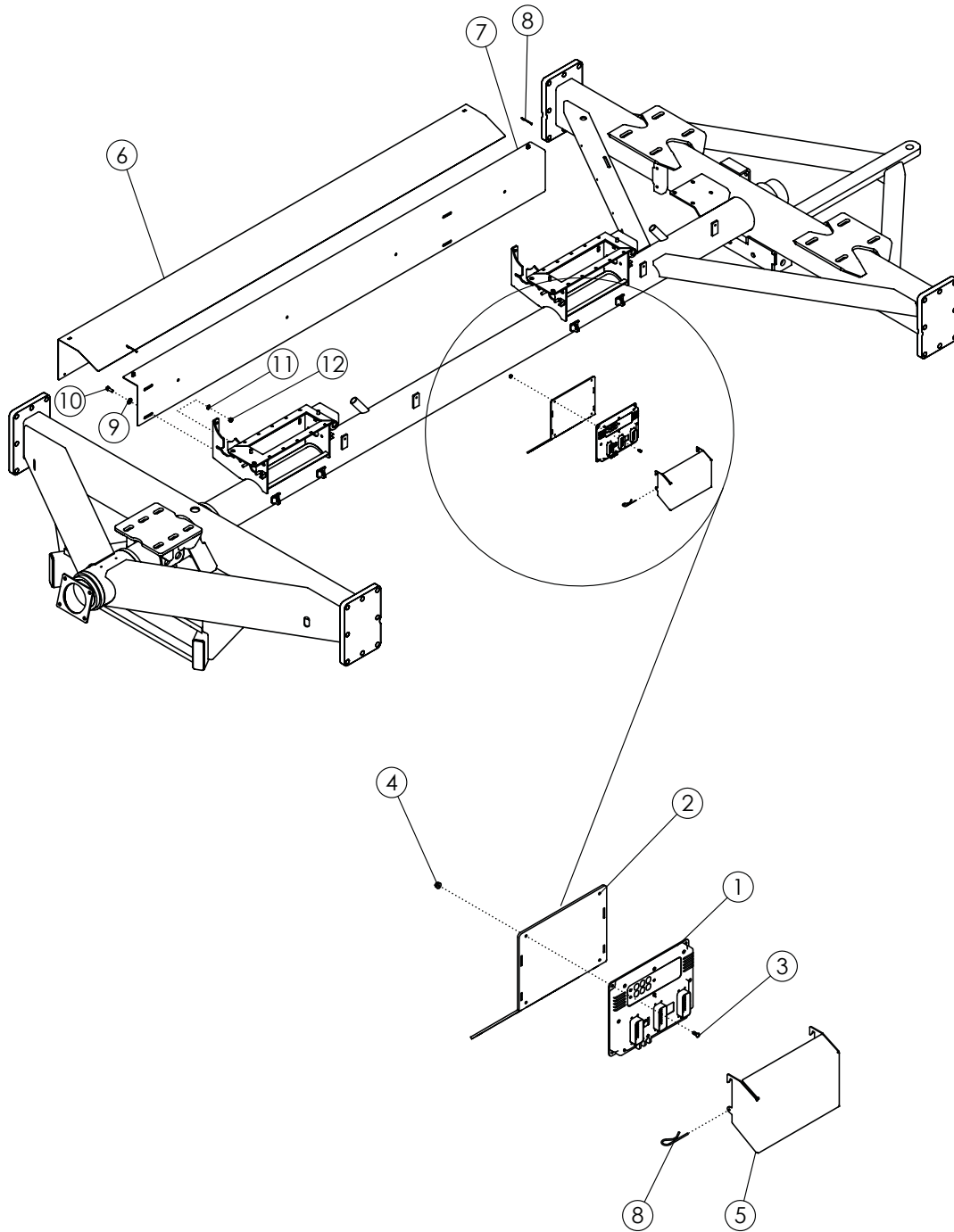

M6001

ASSY-ECU MOUNT

Ref.	Part No.	Description	Qty.
1	330339	ECU-D3 ISO CONTROLLER (ICON)	1
2	67219	PLATE-ECU MOUNT	1
3	1013462	SCREW	4
4	1026591	NUT-K-LOCK: .19 NC GR2 ZP	4
5	67249	COVER-ECU MOUNT	1
6	65452	COVER-HOSE MOUNT	1
7	66006	WLDMT-SHIELD BOX	1
8	1012901	PIN-HAIR: .13 X 2.50 ZP	2
9	1011828	WASHER-FLAT .38 ZP	2
10	1011600	BOLT-HEX: .38 X 1.00 NC GR5 ZP	2
11	1011586	WASHER-LOCK: .38 ZP	2
12	1011576	NUT-HEX: .38 NC GR2 ZP	2
13	67088	TANK HARNESS (NOT SHOWN)	1
14	67492	HARNESS-TANK COMPONENT SHORT (NOT SHOWN)	2
15	67514	1/4" WIRE MOUNT (NOT SHOWN)	4
16	67515	3/8" WIRE MOUNT WITH INSERT (NOT SHOWN)	1
17	66585	WIRE HARNESS PURSE LOCK WHITE CLIP (NOT SHOWN)	11
18	67519	TERMINATING SEAL PLUG (NOT SHOWN)	1
19	1012901	PIN-HAIR: .13 X 2.50 ZP	2

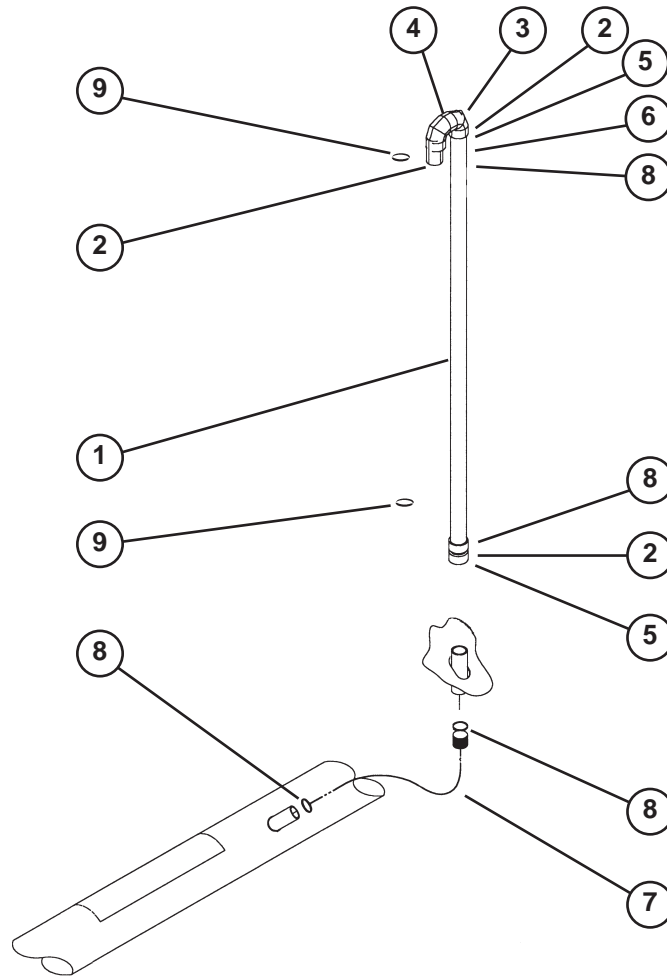

ASSY-PRESSURIZATION KIT

Ref.	Part No.	Description	Qty.
1	65880	HOSE-KANAFLEX 1.25" X INCH LENGTH (2800 AS)	61
		HOSE-KANAFLEX 1.25" X INCH LENGTH (3350 AS)	71
2	65881	PIPE-PVC 1.25" SCH 40 X 4"	4
3	65882	ELBOW-PVC 1.25" SCH 40 F X FG	4
4	65883	PIPE-PVC 1.25" SCH 40 X 3"	2
5	65884	ADAPTER-PVC 1.25" F GLUE X 1.25"	2
6	65885	FTG-PVC 1.25 MP X 1.25 MB	2
7	65880	HOSE-KANAFLEX 1.25" X INCH LENGTH	19.5
8	1013134	CLAMP-HOSE: S.S.#28 1.32-2.25	8
9	65917	CLAMP-HOSE: S.S.#40	4

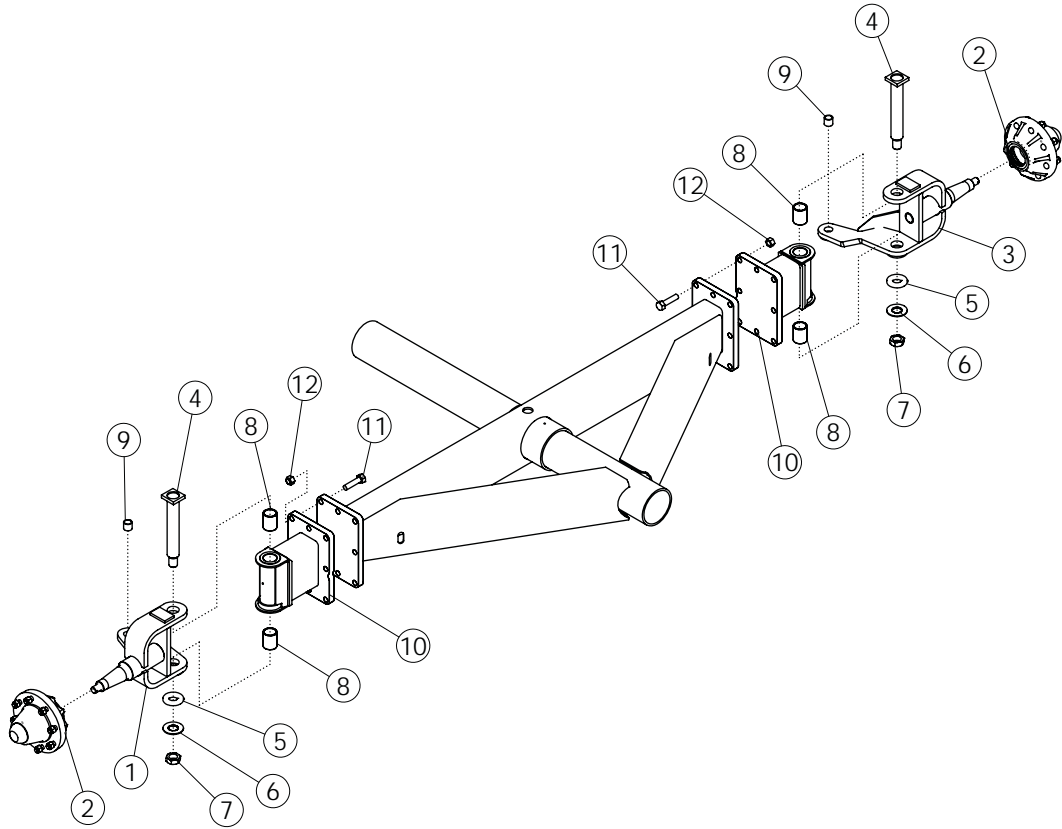

ASSY-AXLES FRONT

Ref.	Part No.	Description	Qty.
1	65429	WLDMT-TRUNION RH	1
2	320150	ASSY-HUB	2
3	65430	WLDMT-TRUNION LH	1
4	65439	WLDMT-KING PIN	2
5	1020688	BEARING-THRUST: TIMKEN T177	2
6	1020675	WASHER-STAR: INTERNAL 1.25" ZP	2
7	65864	NUT-JAM: 1.25 NF GR2 ZP	2
8	65877	BUSHING-MACHINED	4
9	65879	BUSHING-MACHINED	2
10	67693	WLDMT-TRUNION MOUNT	2
11	1012059	BOLT-HEX: .75 X 3.00 NC GR5 ZP	16
12	1017000	NUT-TOPLOCK: .75 NC GR5 ZP	16

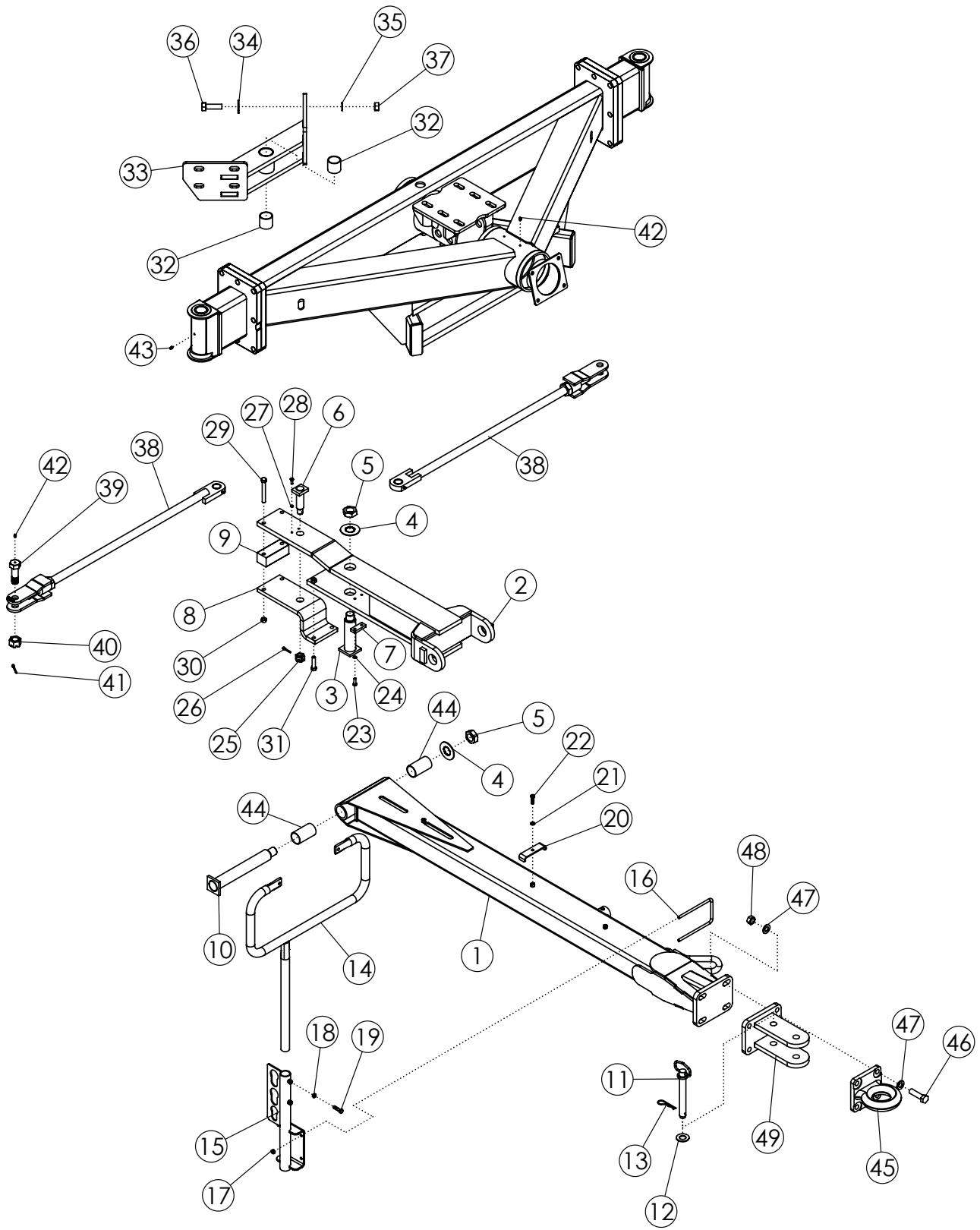

ASSY-DRAWPOLE & STEERING LINKAGE

Ref.	Part No.	Description	Qty.
1	67678	WLDMT-DRAWPOLE	1
2	65432	WLDMT-HITCH	1
3	65442	WLDMT-KING PIN	1
4	1020675	WASHER-STAR: INTERNAL 1.25 ZP	2
5	65864	NUT-JAM: 1.25 NF GR2 ZP	2
6	65440	WLDMT-KING PIN HITCH	1
7	65435	BAR-STOP PLATED	1
8	65433	BRACKET-HITCH	1
9	65434	BLOCK-SPACER	1
10	65441	WLDMT-TOUNGE HINGE BOLT	1
11	1027881	HITCH PIN	1
12	1016663	WASHER-FLAT	1
13	1016115	PIN-HAIR: .19 X 3.25 ZP	1
14	65887	WLDMT-CRADLE HOSE SUPPORT	1
15	66010	WLDMT-MOUNT HOSE SUPPORT	1
16	66005	U-BOLT: .375 X 7.13 X 4 X 7.13	2
17	1016999	NUT-TOPLOCK	4
18	1013519	NUT-JAM: .38 NC GR2 ZP	2
19	1011602	BOLT-HEX: .38 X 1.50 NC GR5 ZP	2
20	65813	BRACKET	1
21	1011586	WASHER-LOCK: .38 ZP	1
22	1011601	BOLT-HEX: .38 X 1.25 CN GR5 ZP	1
23	1011598	BOLT-HEX: .31 X 1.00 NC GR5 ZP	1
24	1029115	WASHER-LOCK: .31 ZP	1
25	65679	NUT-HEX: SLOT .88 NF GR5 ZP	1
26	1012375	PIN-COTTER: .19 X 1.50 NP	1
27	1013242	WASHER-LOCK: .25 ZP	2
28	1011595	BOLT-HEX: .25 X .75 NC GR5 ZP	2
29	1032507	BOLT-HEX: .50 X 4.00 NC GR5 ZP	2
30	1027461	NUT-TOPLOCK: .50 NC GR5 ZP	4
31	1011609	BOLT-HEX: .50 X 2.00 NC GR5 ZP	2
32	65398	BUSHING-MACHINED 1.765 X 2.00 X 1.875	2
33	65760	WLDMT-HITCH PIVOT	1
34	1030702	WASHER-FLAT: .75 ZP	8
35	1012061	WASHER-LOCK: .75 ZP	8
36	1016598	BOLT-HEX: .75 X 2.50 NC GR5 ZP	8
37	1011620	NUT-HEX: .75 NC GR2 ZP	8
38	66092	ASSY-TIE ROD	2
39	65438	BOLT-TIE ROD ZP	2
40	65680	NUT-HEX: 1.00 NC GR2 ZP	2
41	1013473	PIN-COTTER: .19 X 2.00 NP	2
42	1011748	ZERK-GREASE: .25 UNF STRAIGHT	6
43	1011747	ZERK-GREASE: .25 UNF 90°	2
44	67649	BUSHING-MACHINED 1.765 X 2.00 X 3.50	4
45	35801	TOW RING-66,000 LB (OPTIONAL)	1
46	62096	BOLT-HEX: .75 X 2.50 NC GR8 ZP	4
47	35132	WASHER-FLAT: SAE .75 YZP GR8	8
48	1011434	NUT: .75 NC GR8 ZP	4
49	67679	WLDMT-DRAWPOLE CLEVIS	1
50	65829	JACK STAND 2000 LB (NOT SHOWN)	1

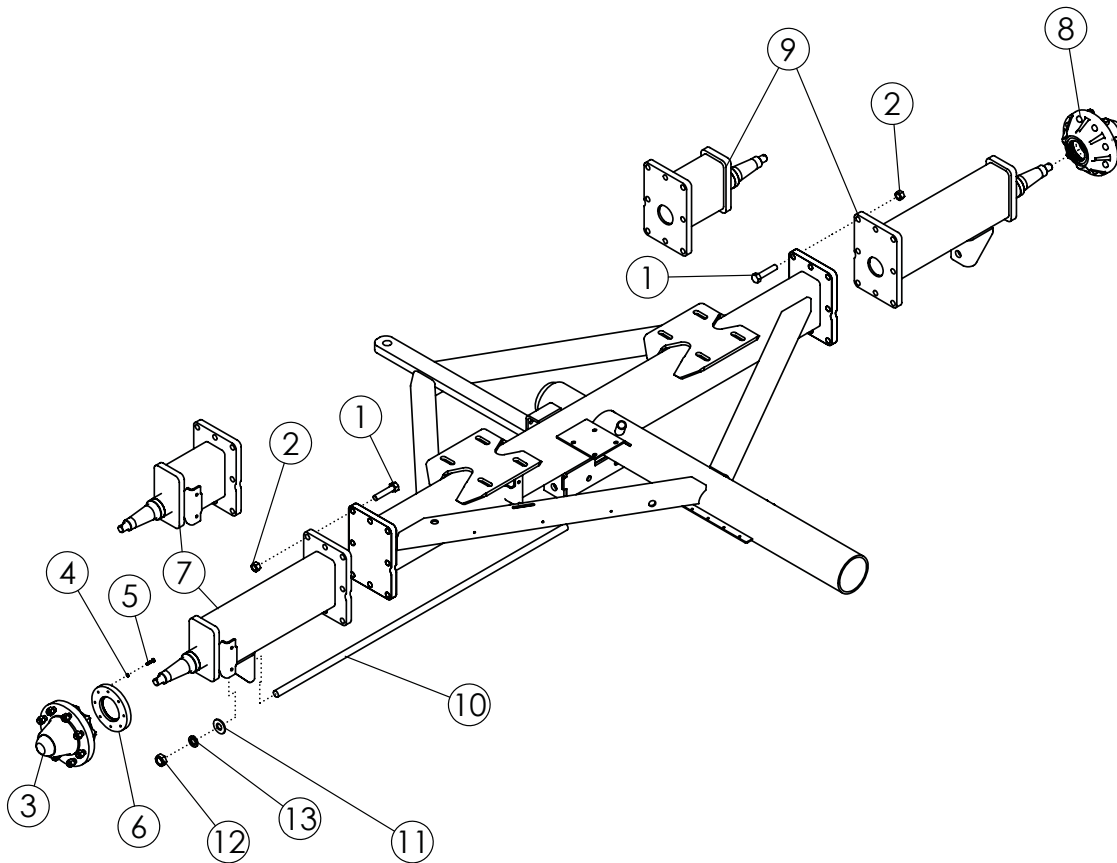

ASSY-AXLES REAR 150"

Ref.	Part No.	Description	Qty
1	58369	BOLT-HEX: .75 X 3.50 NC GR5 ZP	16
2	1013834	NUT-NYLOCK: .75 NC GR2 ZP	16
3	320159	ASSY-HUB 8 BOLT W/BRAKE	1
4	1013242	WASHER-LOCK: .25	8
5	1013940	BOLT: .25 X 1.25 NC ZP	8
6	65425	FLANGE & SPROCKET	1
7	65436	WLDMT-SPINDLE RH DRIVE (150")	1
	65943	WLDMT-SPINDLE RH (120")	1
8	320150	ASSY-HUB 8 BOLT W/O BRAKE	1
9	65437	WLDMT-SPINDLE LH (150")	1
	65177	WLDMT-SPINDLE LH (120")	1
10	65683	ROD-TRUSS ZP (150" AXLE ONLY)	2
11	1020685	WASHER-FLAT: 1.00 ZP (150" AXLE ONLY)	4
12	1012664	NUT-HEX: 1.00 NC GR2 ZP (150" AXLE ONLY)	4
13	1013539	WASHER-LOCK: 1.00 ZP (150" AXLE ONLY)	4

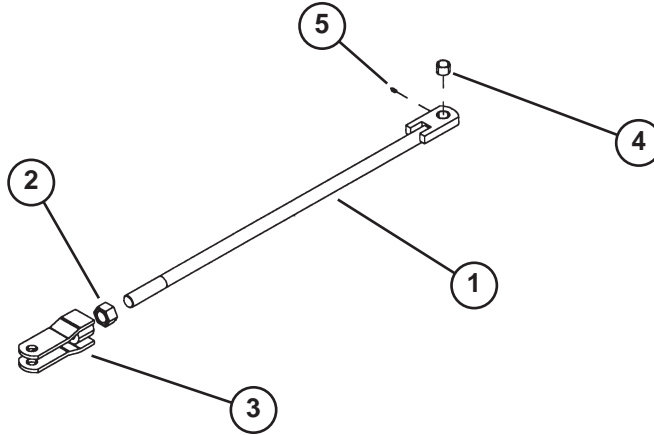

ASSY-TIE ROD

Ref.	Part No.	Description	Qty.
1	65536	TIE ROD - W/BUSHING	1
2	65864	NUT-JAM: 1.25 NF GR2 ZP	1
3	65270	TIE ROD CLEVIS-ZP	1
4	65878	BUSHING-MACHINED	1
5	1011748	ZERK-STRAIGHT: .25 UNF	1

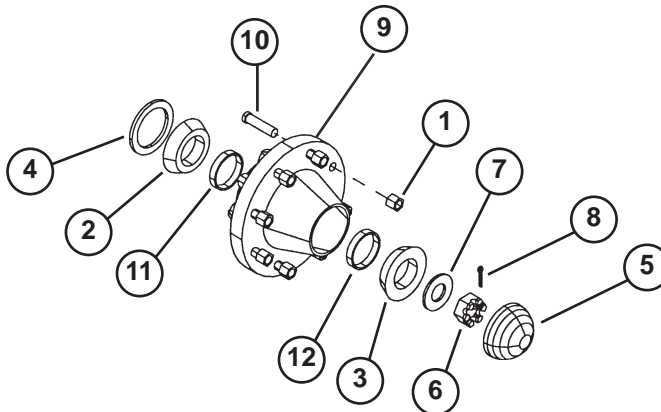

ASSY-HUB

Ref.	Part No.	Description	Qty.
	320159	ASSY-HUB 8 BOLT W/BRAKE (BLACK)(INCLUDES 1-6 &9)	1
	320150	ASSY-HUB 8 BOLT W/O BRAKE (BLACK)(INCLUDES 1-6 &9)	3
1	1013470	NUT-BEVELED	8
2	65987	CONE-INNER	1
3	1012354	CONE-OUTER	1
4	1017764	SEAL	1
5	320152	CAP-HUB	1
6	1030726	NUT-SPINDLE	1
7	1030728	WASHER-SPINDLE	1
8	1030797	PIN-COTTER	1
9	320160	HUB-8 BOLT W/BRAKE (INCLUDES 10-12)	1
	320151	HUB-8 BOLT W/O BRAKE (INCLUDES 10-12)	
10	65944	STUD-LUG	8
11	65948	CUP-INNER	1
12	1012359	CUP-OUTER	1

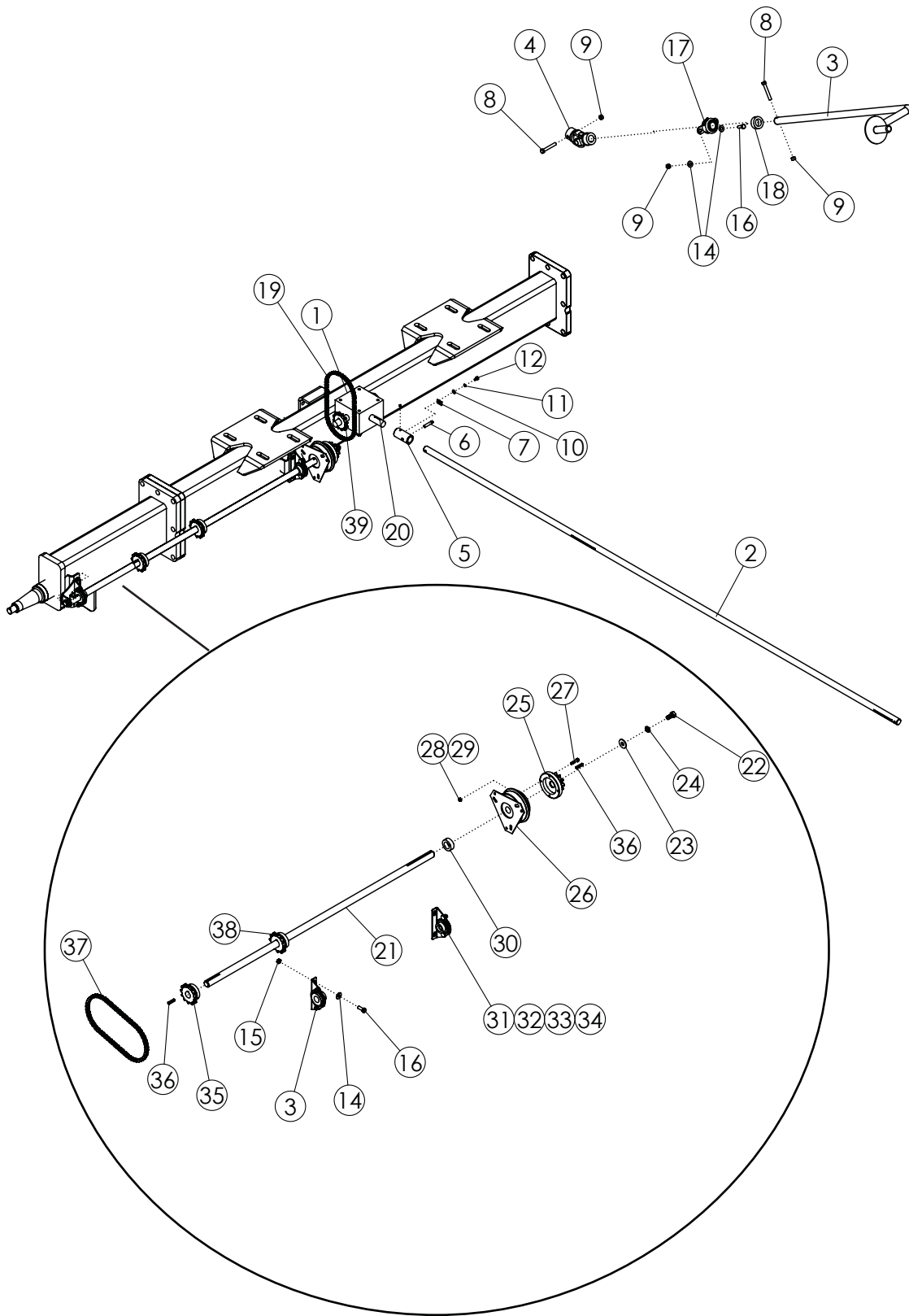

ASSY-METER DRIVELINE

Ref.	Part No.	Description	Qty.
1	65649	GEARBOX-PRARIE (1:1) PAINTED	1
	330132	SEAL GEARBOX (65649)	
2	65567	SHAFT-METERDRIVE	1
3	65688	WLDMT-METER CRANK	1
4	65826	U-JOINT	1
5	65552	COUPLER	1
6	1013218	PIN-SHEAR: BRASS	1
7	1013221	STRIP-SHEAR PIN	1
8	65693	BOLT-HEX: SS .38 X 2.50 NC	2
9	1033268	NUT-NYLOCK: SS .38 NC GR2	3
10	65695	WASHER-FLAT: SS .25	1
11	65696	WASHER-LOCK: SS .25	1
12	65692	BOLT-HEX: SS .25 X .50 NC	1
13	1013044	SCREW-SET: .25 X .25 NC GR8 NP	1
14	1033262	WASHER-FLAT: SAE SS .38	9
15	1016999	NUT-TOPLOCK: .38 NC GR5 ZP	3
16	1033271	BOLT-HEX: SS .38 X 1.00 NC	6
17	1030961	BEARING FLANGE ASSY MODIFIED	1
18	65694	COLLAR SET SS 1.00	1
19	65699	CHAIN-ROLLER 60-1R-031 NICKEL PLT	1
	65701	LINK-CONNECTOR #60 NICKEL PLT	1
	65725	LINK-OFFSET #60 NICKEL PLT	1
20	65715	KEY .250 X .250 X 1.250 SS	4
21	65945	SHAFT-CLUTCH DRIVE 120" ZP	1
	65654	SHAFT-CLUTCH DRIVE 150" ZP	1
22	1011096	BOLT-HEX: .50 X 1.00 NC GR5 ZP	1
23	1014443	WASHER-FLAT: .50 ZP	1
24	1011581	WASHER-LOCK: .50 ZP	1
25	65553	ASSY-ADAPTER	1
26	1021090	CLUTCH-ELECTRIC	1
27	1013940	BOLT-HEX: .25 X 1.25 NC GR5 ZP	4
28	1011587	NUT-HEX: .25 NC GR2 ZP	4
29	1013242	WASHER-LOCK: .25 ZP	4
30	66181	BUSHING-ADAPTER	1
31	1018571	BEARING-PILLOW BLOCK	2
32	65702	BOLT-CRG: .31 X 0.75 NC GR5 ZP	4
33	1029115	WASHER-LOCK: .31 ZP	4
34	1011575	NUT-HEX: .31 NC GR2 ZP	4
35	1012976	SPROCKET-60BS10 X 1.00 MARTIN	1
36	65715	KEY .250 X .250 X 1.250 SS	2
37	65703	CHAIN-ROLLER 60-1R-027 NICKEL PL (NOT SHOWN)	1
	65704	LINK-CONNECTOR 60 NICKEL PLATED	1
	65724	LINK-OFFSET #60 NICKEL PLATE	1
38	66075	SPROCKET- 60BS12 X 1.00	1
39	1012976	SPROCKET-60BS10 X 1.00 - 23.1R26 HIGH RATE	1
	66075	SPROCKET-60BS12 X 1.00 - 18.4R26 HIGH RATE	
	1025228	SPROCKET-60BS15 X 1.00 - 23.1R26 STANDARD RATE	
	1021069	SPROCKET-60BS17 X 1.00 - 18.4R26 STANDARD RATE	

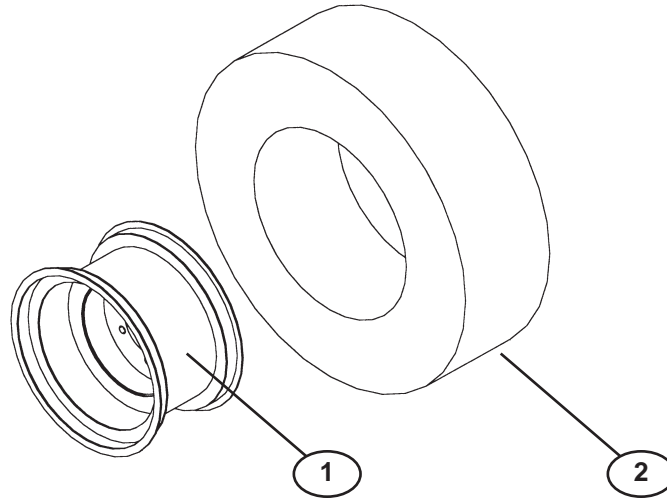

ASSY-W&T 18.4X26 R1 8PLY, 16X26X8

Ref.	Part No.	Description	Qty.
	65685	TIRE-MNTD: 18.4X26 R1 8PLY	4
1	1020719	WHEEL: 16X26 - 8 BOLT	1
2	1030988	TIRE: 18.4X26 R1 8 PLY	1

ASSY-W&T 23.1X26 R1 10PLY, 20X26X8

Ref.	Part No.	Description	Qty.
	65687	TIRE-MNTD: 23.1X26 R1 10-PLY	4
1	1021068	WHEEL: 20X26 - 8 BOLT	1
2	1029689	TIRE: 23.1X26 R1 10 PLY	1

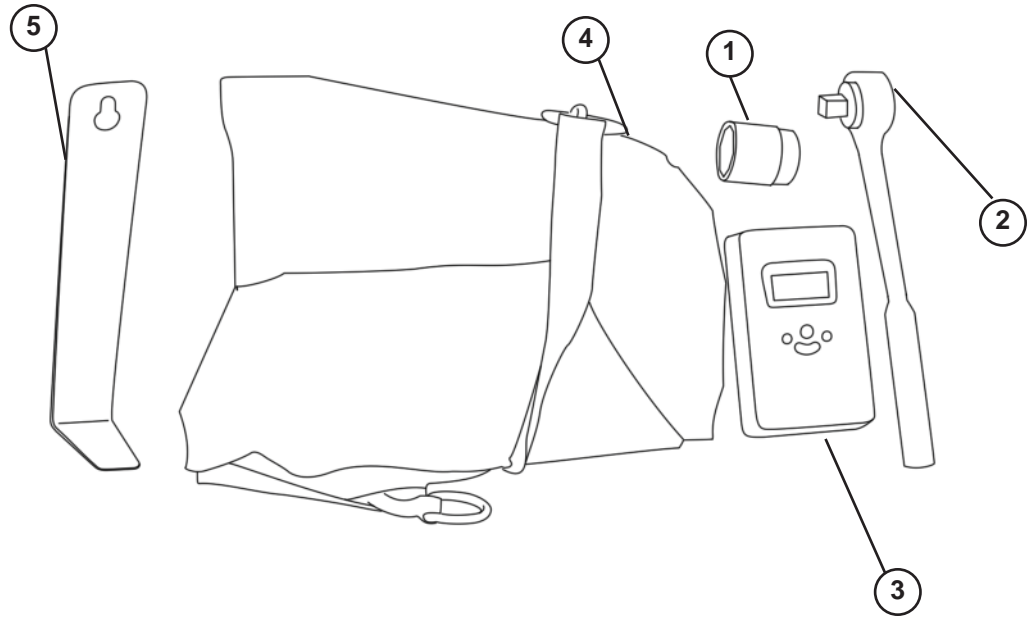

KIT-CALIBRATION COMPONENTS

Ref.	Part No.	Description	Qty.
1	66354	SOCKET-1.125" (.50" DRIVE)	1
2	65890	RATCHET-.50" DRIVE	1
3	1032044	SCALE-CALIBRATION KIT	1
4	1032048	BAG-CALIBRATION KIT	1
5	34569	PLATE-WRENCH SEED DEPTH	1
6	65891	SCREWDRIVER (NOT SHOWN)	1

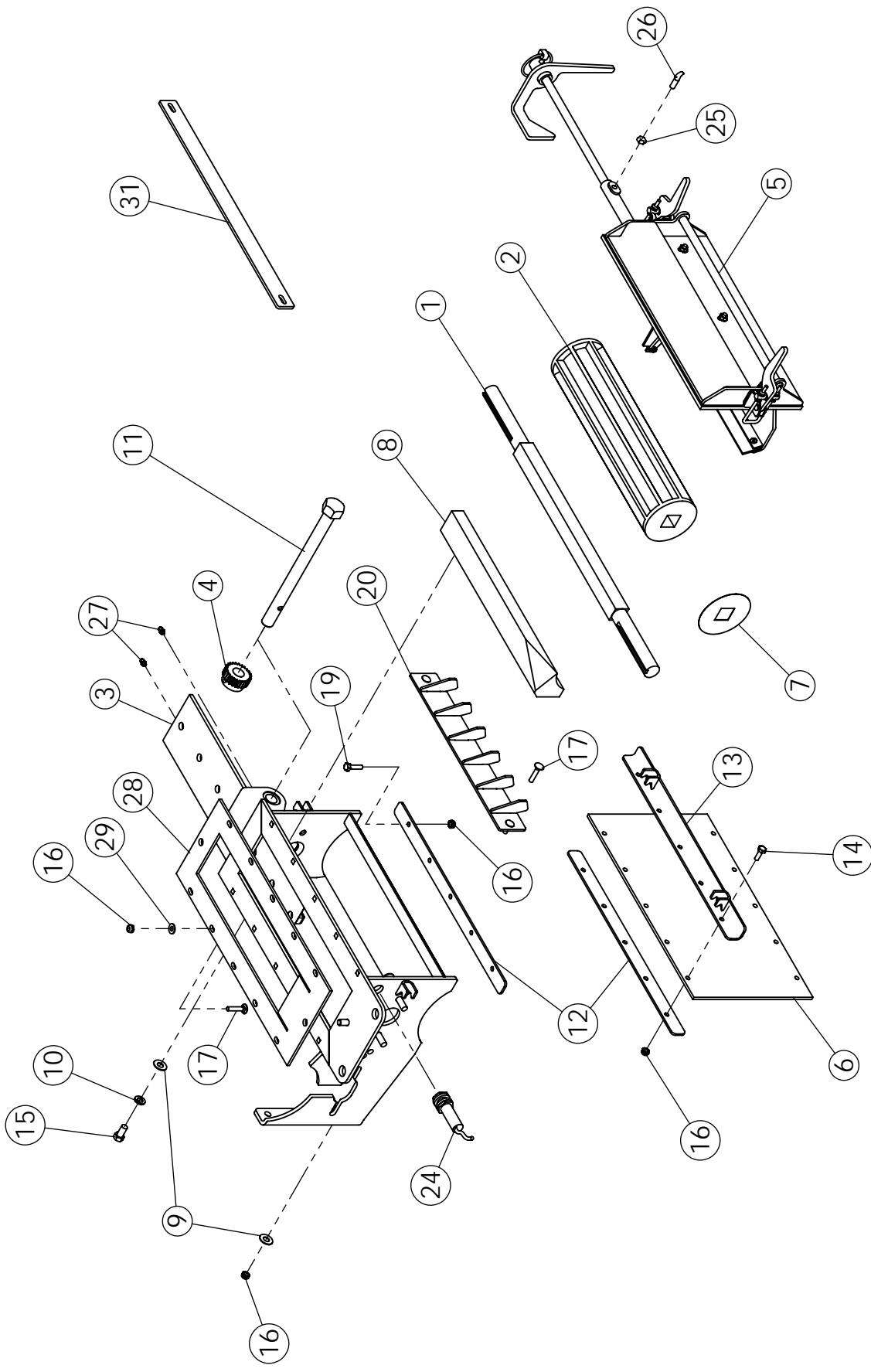

ASSY-METER BOX

Ref.	Part No.	Description	Qty.
1	65650	SHAFT-METER ROLL	1
2	65705	WLDMT-METER ROLL - HIGH VOLUME	1
	1012608	WLDMT-METER ROLL - MEDIUM VOLUME	
	33851	WLDMT-METER ROLL - LOW VOLUME	
	67639	WLDMT-METER ROLL - FINE PRODUCT	
3	65632	WLDMT-TOP SLIDE IN DOOR	1
4	65707	PINION-SS	1
5	66306	ASSY-MB DOOR W/FLOWPLATE	1
6	65708	RUBBER CLEANOUT DOOR	1
7	65744	PLATE METER ROLL SPACER	AR
8	66062	BLOCK-METER TOP	1
9	1033262	WASHER-FLAT: SAE SS .38	8
10	1011586	WASHER-LOCK: .38 ZP	2
11	65630	BOLT-PIN ADJUSTMENT	1
12	65629	PLATE-CLEANOUT RETAINER	2
13	65626	WLDMT-ANGLE LATCH	1
14	1033270	BOLT-HEX: SS .25 X .75 NC	5
15	66375	BOLT-HEX: SS .38 X 1.00 NC	2
16	1033269	NUT-NYLOCK: SS .25 NC GR2	20
17	66043	BOLT-CRG: SS .25 X 1.25 NC	12
18	1011576	NUT-HEX: .38 NC GR2 ZP	4
19	66077	BOLT-HEX: SS .25 X 1.00	5
20	67484	WLDMT-MB AIR DAM	1
21	1032044	SCALE-CLAIBRATION KIT (NOT SHOWN)	1
22	64503	GLUE-MASTERBRAND GASKET (NOT SHOWN)	1.75
23	66098	ASSY-CLEANOUT DOOR (INCLUDES ITEMS 12,13,14,16,23)	1
24	66511	SENSOR TURCK (WITH END)	1
25	1023719	NUT-JAM: SS .31NC	1
26	66316	SCREW-THUMB SP HEAD .313-18 X .75 SS	1
27	1011748	ZERK-GREASE: .25 UNF STRAIGHT	2
28	65512	GASKET-SEEDBOX .250	1
29	65695	WASHER-FLAT: .25 SS	10
30	66097	ASSY-DEFLECTOR (NOT SHOWN)	1
31	65490	PLATE-INDICATOR DECAL	1

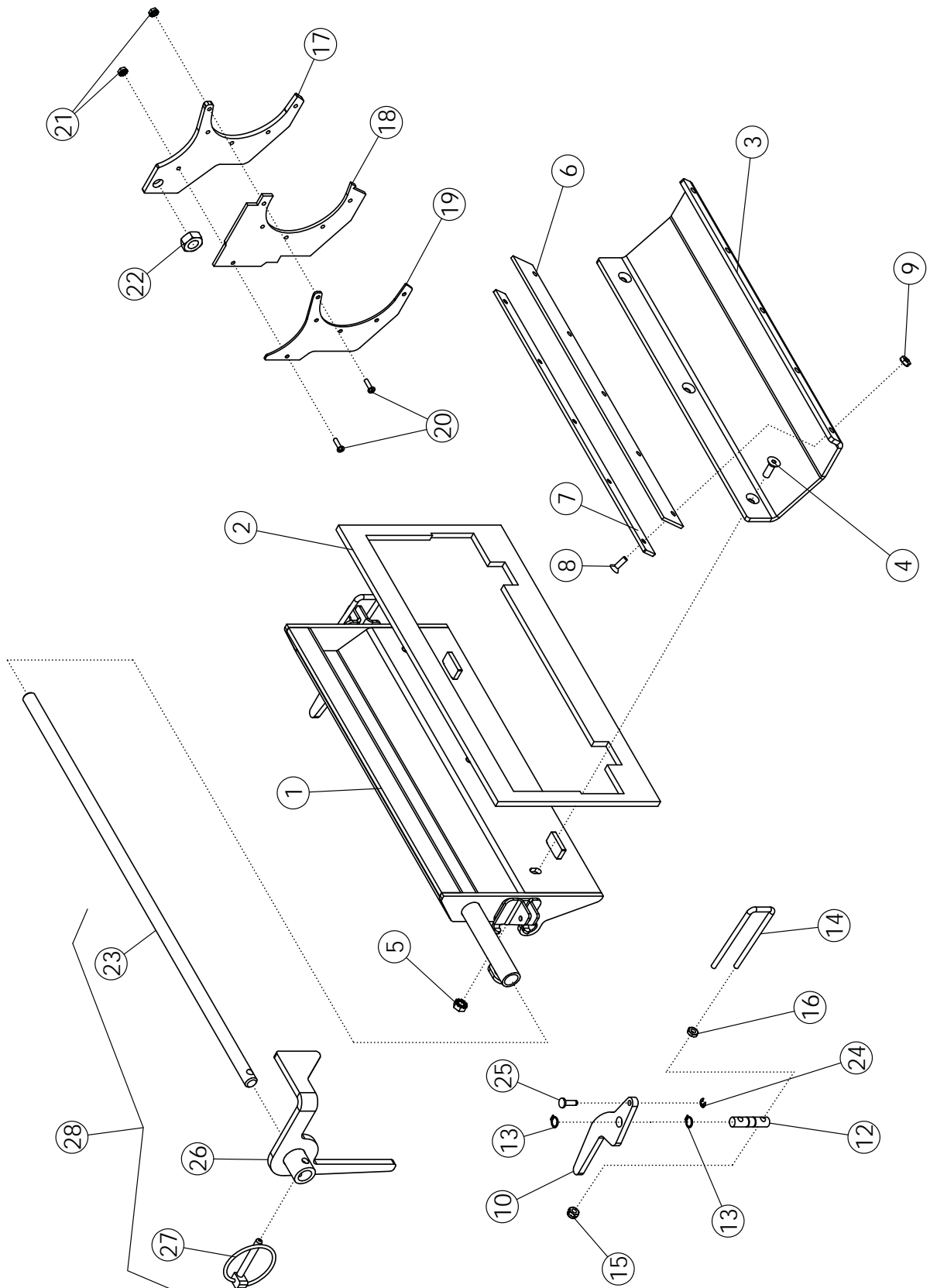

ASSY-METER BOX DOOR

Ref.	Part No.	Description	Qty.
1	66305	WLDMT-MB DOOR	1
2	66344	GASKET-RUBBER MB DOOR	1
3	66300	PLATE-MB SEED TRAY	1
4	66347	SCREW F-H-S-C: .25 X .75 NC SS	3
5	66348	NUT-K-LOCK: .25 NC SS	3
6	66345	WIPER RUBBER	1
7	66310	SHEET-MB WIPER MOUNT	1
8	1032095	SCREW-F-H-S-C: .19 X .625 NC SS	5
9	1032059	NUT-K-LOCK: 18-8 SS .19 NC	5
10	65640	PLATE-METER CLAMP HANDLE	2
12	65639	SHAFT-METER LATCH	2
13	67499	RING-RETAINING .375 SS	4
14	65655	U-BOLT: SS .188 X 3.25 X .875 X 3.25	2
15	65712	NUT-NYLOCK: 10-24 GR2 SS	4
16	65348	NUT-HEX: SS 10-24	4
17	66307	PLATE-MB FLOW CONTROL	1
18	66346	SEAL-RUBBER FLOW CONTROL	1
19	66309	PLATE-MB FLOW CONTROL	1
20	1032093	SCREW-P-H: #6 X .50 NC SS	6
21	1032094	NUT-K-LOCK: 18-8 SS .19 NC	6
22	1032190	NUT-JAM: .50 NC SS	1
23	65661	ROD-FLOW CONTROL	1
24	67498	E-CLIP: .188 SS	2
25	67497	PIN-METER LATCH	2
26	65662	WLDMT-INDICATOR	1
27	65311	PIN-LYNCH: .25 X 1.563	1
28	65651	ASSY-FLOW CONTROL ROD	1

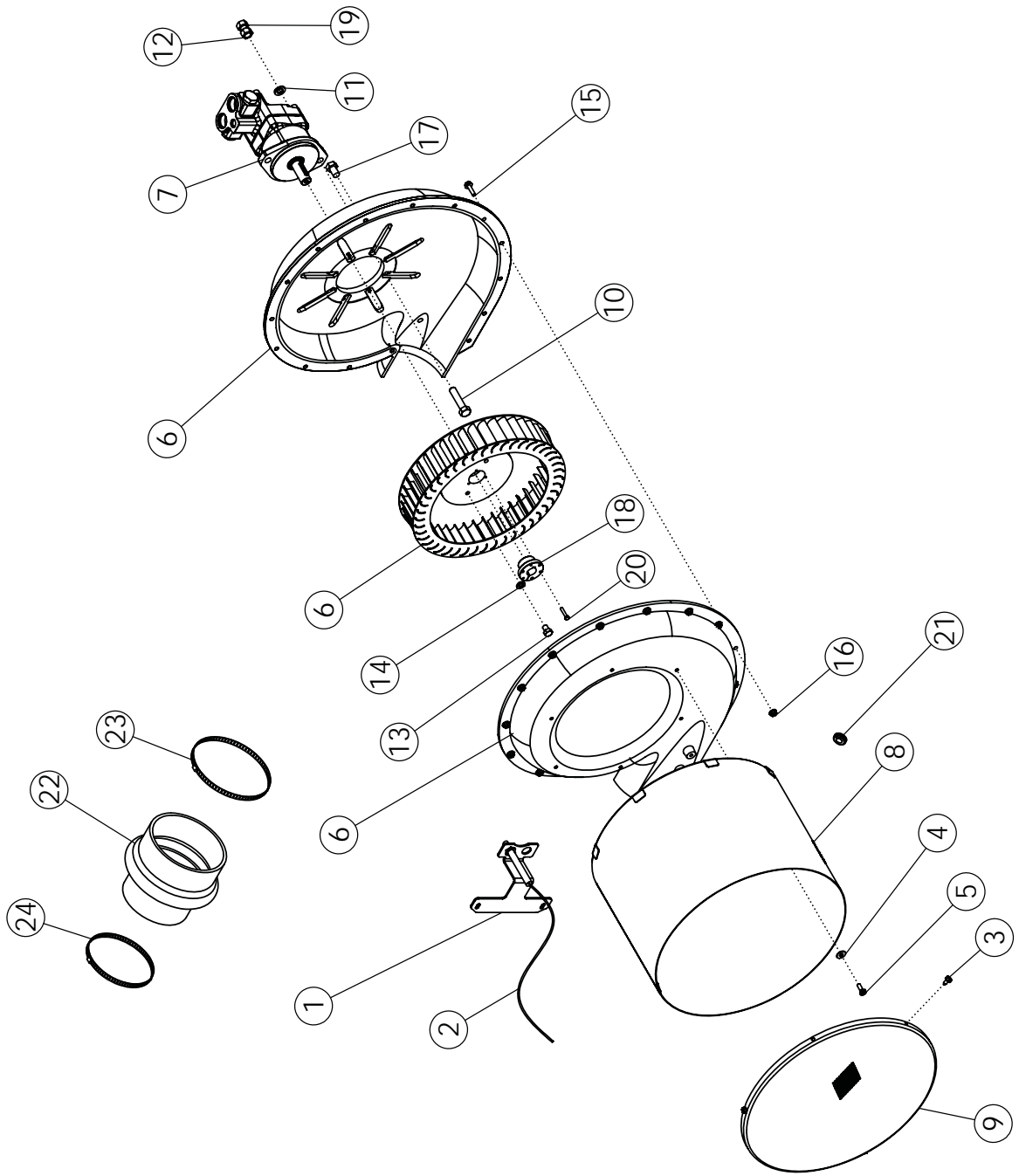

ASSY-BLOWER

Ref.	Part No.	Description	Qty.
1	66350	BRACKET-FAN SPEED SENSOR	1
2	66510	SENSOR-FAN SPEED (ISO)	1
3	1020555	SCREW-ZIPIN TAP: #12 X 1/2"	3
4	1020416	WASHER-FLAT: .25 ZP	6
5	1011595	BOLT-HEX: .25 X .75 NC GR5 ZP	6
6	1020418	FAN-HYDRAULIC DRIVE 6"	1
7	66244	MOTOR-HYDRAULIC W/CHECK PAINTED	1
	66752	SEAL-MOTOR SHAFT	
8	1020543	WLDMT-SCREEN	1
9	1020540	SCREEN-END	1
10	1017708	BOLT-HEX: .50 X 2.25 NC GR5 ZP	2
11	1011581	WASHER-LOCK: .50 ZP	2
12	1011577	NUT-HEX: .50 NC ZP	2
13	1021800	BOLT-HEX: .38 X .50 NC GR5 ZP	2
14	1011586	WASHER-LOCK: .38 ZP	2
15	63671	BOLT-FLANGE: .25 X 1.00 NC GR5 ZP	15
16	65349	NUT-FLANGE: .25 NC GR5 ZP	15
17	1013020	BOLT-HEX: .50 X .75 NC FR5 ZP	2
18	1020459	BUSHING 20MM	1
19	1027461	NUT-TOPLOCK: .50 NC GR5 ZP	2
20	66099	ASSY-BLOWER HYDRAULIC	1
21	67511	GROMMET-RUBBER 13/16"	1
22	1014892	HOSE-HUMP REDUCER	1
23	66221	CLAMP-HOSE: #104 4.13-7.00	1
24	1026256	CLAMP-HOSE: #88 3.13-6.00	1
25	66099	ASSY-BLOWER HYDRAULIC (INCLUDES ITEMS 3-19)	1
26	1020801	SCREEN 6" (INCLUDES ITEMS 3, 8, AND 9)	1

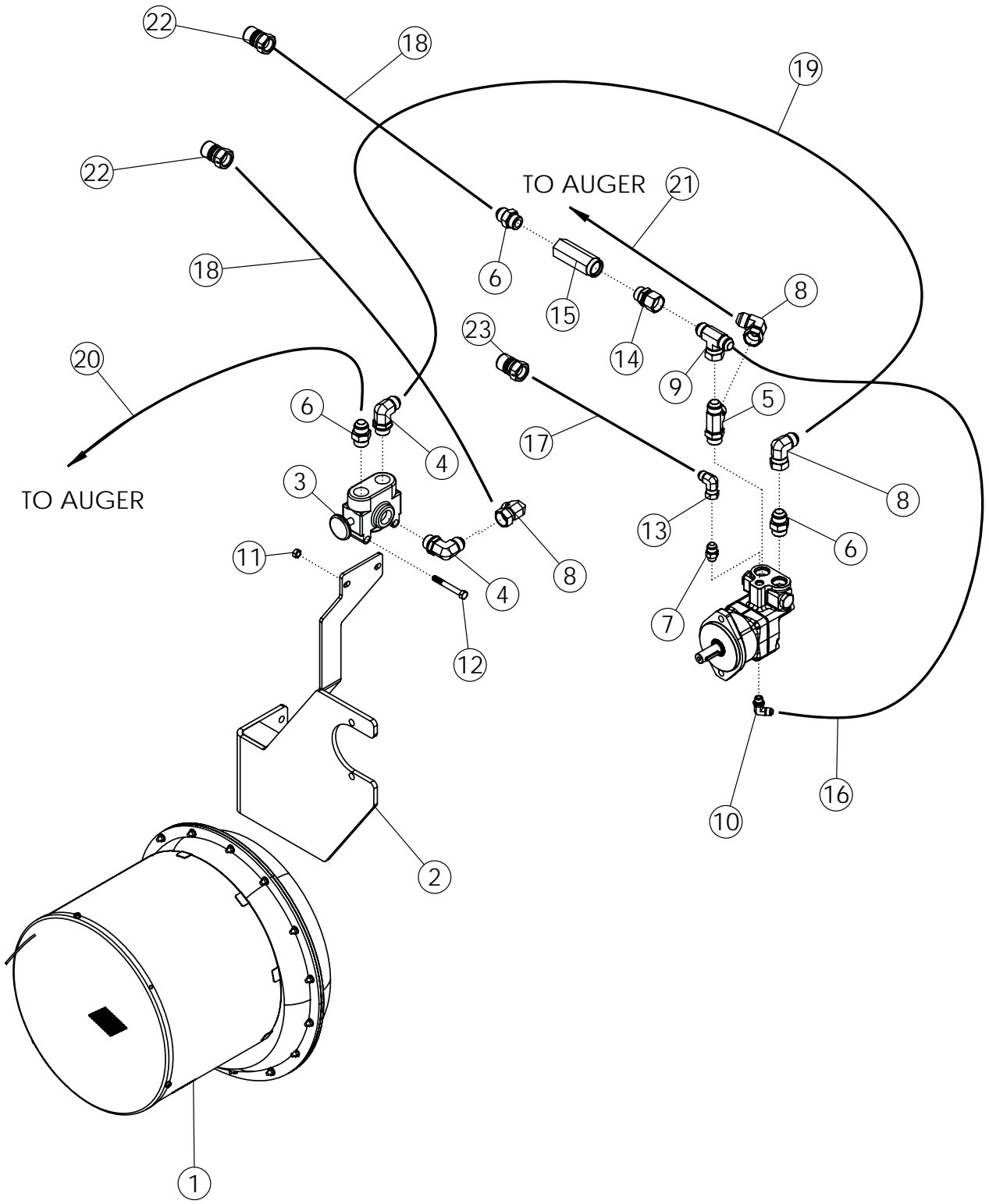

ASSY-BLOWER HYDRAULIC GROUND DRIVE

Ref.	Part No.	Description	Qty.
1	66099	ASSY-BLOWER HYDRUALIC	1
2	65718	WLDMT - FAN MOUNT	1
3	65846	VALVE-SELECTOR PAINTED (3-WAY)	1
4	64060	12MB-12MJ-90	2
5	66248	12MB-12MJ-12MJ	1
6	65918	FTG-ADAPTER: 12MB-12MJ	3
7	62024	6MB-8MJ	1
8	59041	12MJ-12FJX-90	3
9	59053	12MJ-12MJ-12FJX TEE	1
10	66270	6MB-6MJ-90	1
11	1016999	NUT-TOPLOCK: .38 NC GR5 ZP	2
12	1013239	BOLT-HEX: .38 X 3.00 NC GR5 ZP	2
13	57668	8MJ-8FJX-90	1
14	66249	FTG-ADAPTER: 12MB-12FJX	1
15	65857	VALVE-CHECK SAE #12	1
16	330077	HOSE: .50 X 024 12FJX-6FJX	1
17	67670	HOSE: .50 X 312 8MB-8FJX	1
18	67671	HOSE: .75 X 310 12FJX-12MB	2
19	65918	HOSE: .75 X 024 12FJX-12FJX	1
20	65898	HOSE: .50 X 240 12FJX-12FJX-90 (8" AND 10")	1
21	65897	HOSE: .50 X 240 12FJX-12FJX (8" AND 10")	1
22	37064	QUICK COUPLING-MALE 12-12 ORB	2
23	37065	QUICK COUPLING-MALE 8-10 ORB	1

+ CASE DRAIN COUPLERS AT TRACTOR

Ref.	Part No.	Description	Qty.
24	69119	FTG-CASE DRAIN JD & CNH (NOT SHOWN)	AR
25	69120	FTG-MOTOR RETURN LINE (NOT SHOWN)	AR
26	66199	PIONEER TIP 8010-15 (NOT SHOWN)	AR
27	66961	FTG-ADAPTER: 8FB-12MB (NOT SHOWN)	AR
28	37066	QUICK COUPLING-FEMALE -12-12 ORB (NOT SHOWN)	AR
29	37067	QUICK COUPLING-FEMALE -8-10 ORB (NOT SHOWN)	AR

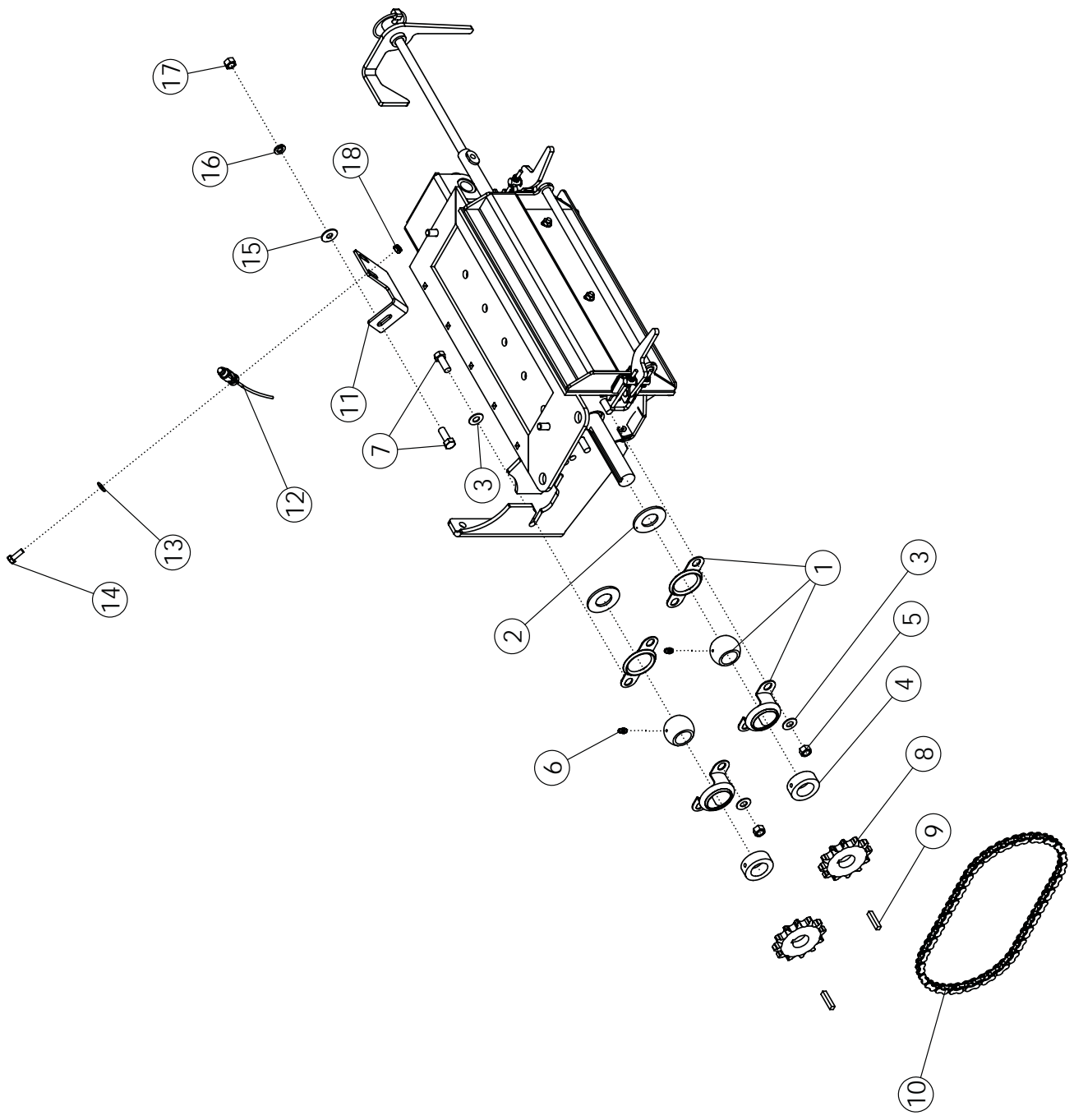

ASSY-GROUND DRIVE

Ref.	Part No.	Description	Qty.
1	1012986	BEARING-FLANGE/A	2
2	1012978	WASHER-RUBBER	2
3	1033262	WASHER-FLAT: SAE SS .38	5
4	65694	COLLAR-SET: 1.00 SS	2
5	1011576	NUT-HEX: .38 NC GR2 ZP	4
6	1011748	ZERK-GREASE: .25 UNF STRAIGHT	3
7	1033271	BOLT-HEX: SS .38 X 1.00 NC	2
8	65698	SPROCKET SS #40	2
9	65715	KEY .250 X .250 X 1.250 SS	2
10	65700	CHAIN ROLLER 40-1R-039 SS	1
	65697	LINK CONNECTOR SS #40	1
	65726	LINK OFFSET #40 SS	1
11	66587	BRACKET-SHAFT SENSOR	1
12	66507	SENSOR-SPEED/SHAFT	1
13	65695	WASHER-FLAT: SS .25	1
14	1033270	BOLT-HEX: SS .25 X .75 NC	1
15	65778	WASHER-FLAT: SS .38	1
16	65706	WASHER-LOCK: SS .38	1
17	1032089	NUT-HEX: SS .38 NC	1
18	1033269	NUT-NYLOCK: SS .25 NC GR2	1

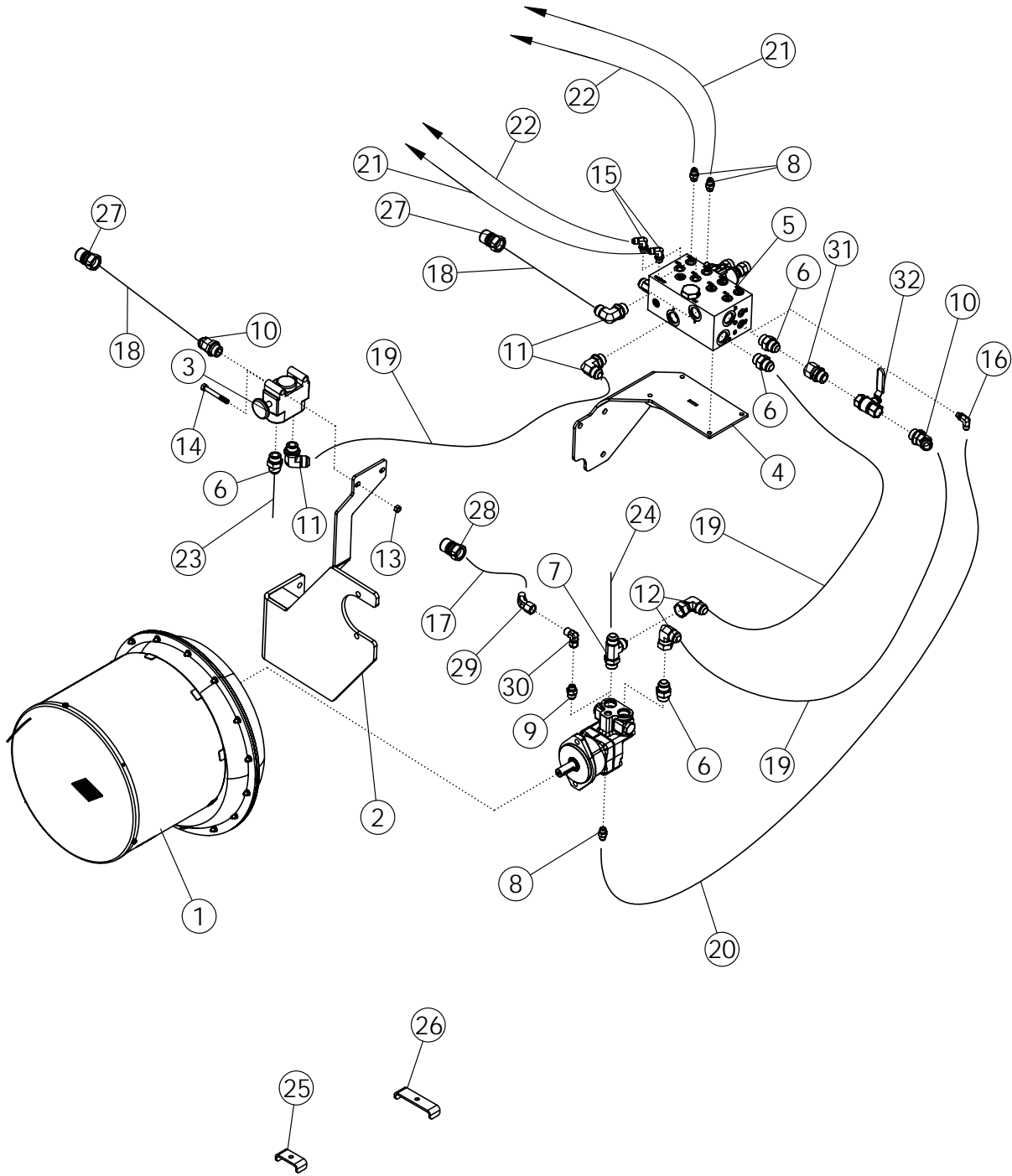

ASSY-BLOWER HYDRAULIC DRIVE

Ref.	Part No.	Description	Qty.
1	66099	ASSY-BLOWER	1
2	65718	WLDMT-FAN MOUNT	1
3	65846	VALVE-SELECTOR PAINTED (3-WAY)	1
4	67500	WLDMT-VALVE MOUNT	1
5	66938	VALVE-VARIABLE RATE 2-BANK W/CHECK	1
6	65918	FTG-ADAPTER: 12MB-12MJ	4
7	66248	FTG-TEE: 12MB-12MJ-12MJ	1
8	37259	FTG-ADAPTER: 6MB-6MJ	3
9	62024	FTG-ADAPTER: 6MB-8MJ	1
10	63699	FTG-ELBOW: 12MB-12MJ-45	2
11	64060	FTG-ELBOW: 12MB-12MJ-90	3
12	59041	FTG-ELBOW: 12MJ-12FJX-90	3
13	1016999	NUT-TOPLOCK: .38 NC GR5 ZP	2
14	1013239	BOLT-HEX: .38 X 3.00 NC GR5 ZP	2
15	57754	FTG-ELBOW: 6MB-6MJ 90	2
16	67513	FTG-ELBOW: 4MB-6MJ 90	1
17	67670	HOSE: .50 X 312 8MB-8FJX	1
18	67671	HOSE: .75 X 310 12FJX-12MB	2
19	66245	HOSE: .75 X 024 12FJX-12FJX	3
20	67505	HOSE: .38 X 018 6FJX-6FJX	1
21	67506	HOSE: .38 X 080 6FJX-6FJX90	2
22	67507	HOSE: .38 X 150 6FJX-6FJX90	2
23	65898	HOSE: .50 X 240 12FJX-12FJX-90 (8" AND 10")	1
24	65897	HOSE: .50 X 240 12FJX-12FJX (8" AND 10")	1
25	50714	CLAMP .50 ZP	1
26	65813	BRACKET	3
27	37064	QUICK COUPLING-MALE 12-12 ORB	2
28	37065	QUICK COUPLING-MALE 8-10 ORB	1
29	57663	FTG-ELBOW: 8MJ-8FJX-45	1
30	57668	FTG-ELBOW: 8MJ-8FJX-90	1
31	66249	FTG-ADAPTER: 12MB-12FJX	1
32	33641	VALVE-BALL 3/4" SAE	1

+ CASE DRAIN COUPLERS AT TRACTOR

Ref.	Part No.	Description	Qty.
33	69119	FTG-CASE DRAIN JD & CNH (NOT SHOWN)	AR
34	69120	FTG-MOTOR RETURN LINE (NOT SHOWN)	AR
35	66199	PIONEER TIP 8010-15 (NOT SHOWN)	AR
36	66961	FTG-ADAPTER: 8FB-12MB (NOT SHOWN)	AR
37	37066	QUICK COUPLING-FEMALE -12-12 ORB (NOT SHOWN)	AR
38	37067	QUICK COUPLING-FEMALE -8-10 ORB (NOT SHOWN)	AR

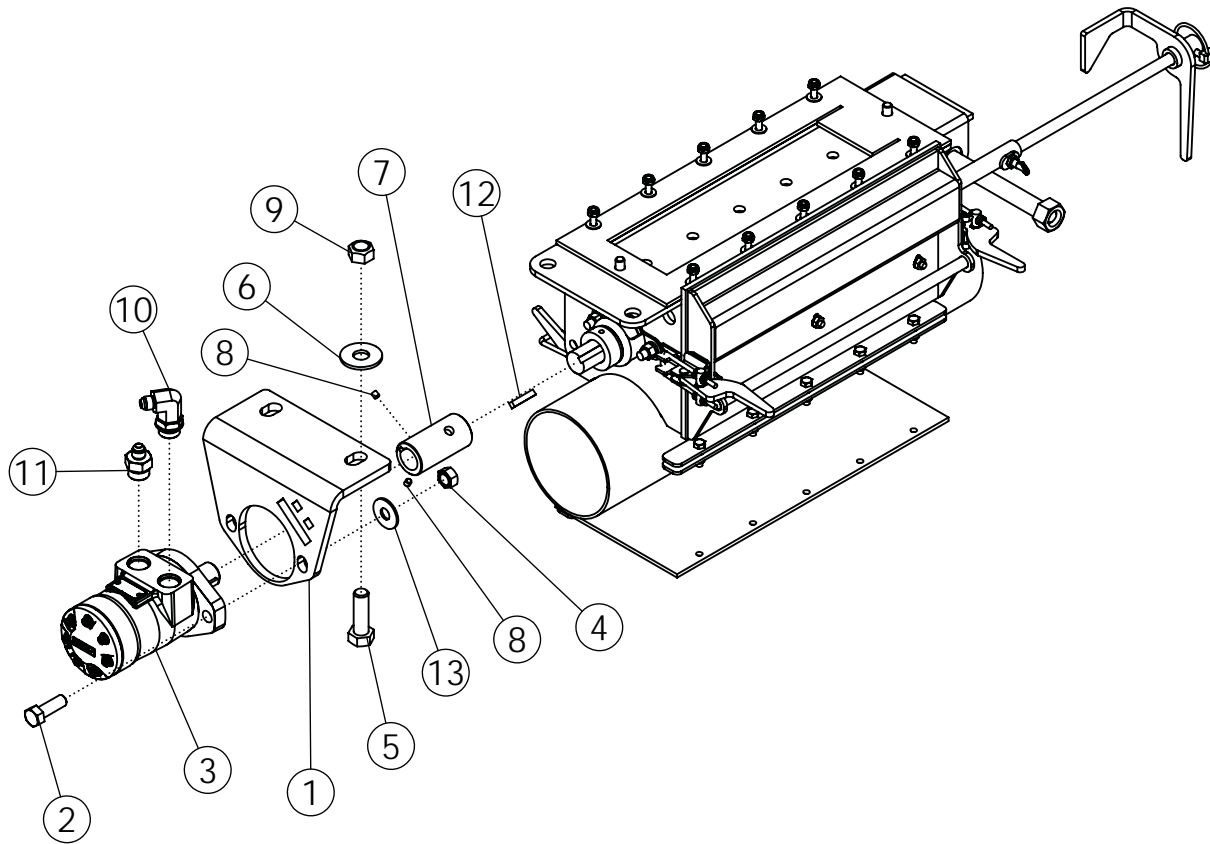

ASSY-HYDRAULIC DRIVE

Ref.	Part No.	Description	Qty.
1	34038	MOUNT-HYD MOTOR METER	1
2	67063	BOLT-HEX: SS .50 X 2.00 NC GR5 ZP	2
3	67481	MOTOR-METER DRIVE 9.7 CID	1
	67518	SENSOR METER SPEED (NOT SHOWN)	
4	67659	NUT-NYLOCK: SS .50 NC GR5 ZP	2
5	34808	BOLT-HEX: SS .63 X 2.00 NC	2
6	67496	WASHER-FLAT: .63 SS	2
7	65552	COUPLER	1
8	1013044	SCREW-SET: .25 X .25 NC GR8 NP	2
9	66445	NUT-NYLOCK: .63 NC GR2 SS	2
10	37042	FTG-ELBOW: 10MB-6MJ 90	1
11	66939	FTG-ADAPTER: 6MJ-10MB	1
12	65715	KEY .250 X .250 X 1.250 SS	1
13	37356	WASHER-FLAT: SS .50 ZP	2
14	67489	HARNES-METER SPEED (NOT SHOWN)	1

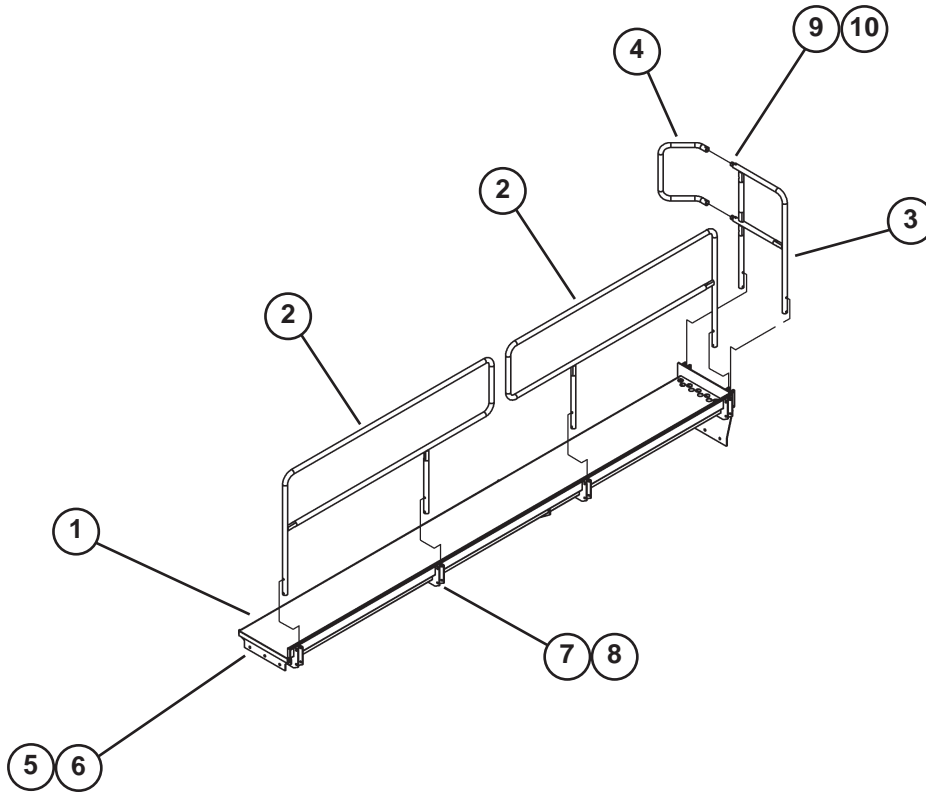

ASSY-CATWALK & HANDRAILS

Ref.	Part No.	Description	Qty.
1	65589	WLDMT-CATWALK	1
2	65598	WLDMT-SIDE RAIL	2
3	65601	WLDMT-FRONT RAIL	1
4	65606	TUBE-FRONT RAILING	1
5	1011606	BOLT-HEX: .50 X 1.25 NC GR5 ZP	9
6	1027461	NUT-TOPLOCK: .50 NC GR5 ZP	9
7	1015174	BOLT-HEX: .38 X 2.50 NC GR5 ZP	12
8	1016999	NUT-TOPLOCK: .38 NC GR5 ZP	12
9	1011603	BOLT-HEX: .38 X 1.75 NC GR5 ZP	2
10	1016999	NUT-TOPLOCK: .38 NC GR5 ZP	2

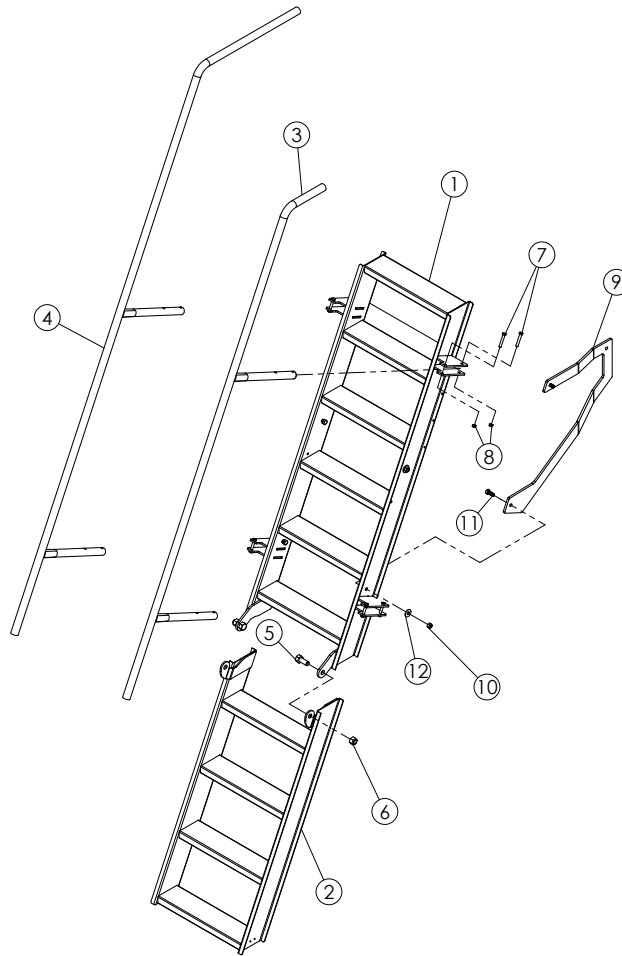

M6018

ASSY-LADDER AIR SYSTEM

Ref.	Part No.	Description	Qty.
1	65607	WLDMT-UPPER LADDER	1
2	65617	WLDMT-LOWER LADDER	1
3	65623	WLDMT-LADDER RAIL RH	1
4	66377	WLDMT-LADDER RAIL LH	1
5	62412	BOLT-HEX: .75 X 1.75 NC GR5 ZP	2
6	1017000	NUT-TOPLOCK: .75 NC GR5 ZP	2
7	59390	BOLT-HEX: .38 X 2.25 NC GR5 ZP	8
8	1016999	NUT-TOPLOCK: .38 NC GR5 ZP	8
9	67100	MOUNTING BRACKET RH	1
	67099	MOUNTING BRACKET LH (NOT SHOWN)	1
10	1027461	NUT-TOPLOCK: .50 NC GR5 ZP	4
11	1011606	BOLT-HEX: .50 X 1.25 NC GR5 ZP	4
12	1014443	WASHER-FLAT: .50 ZP	4

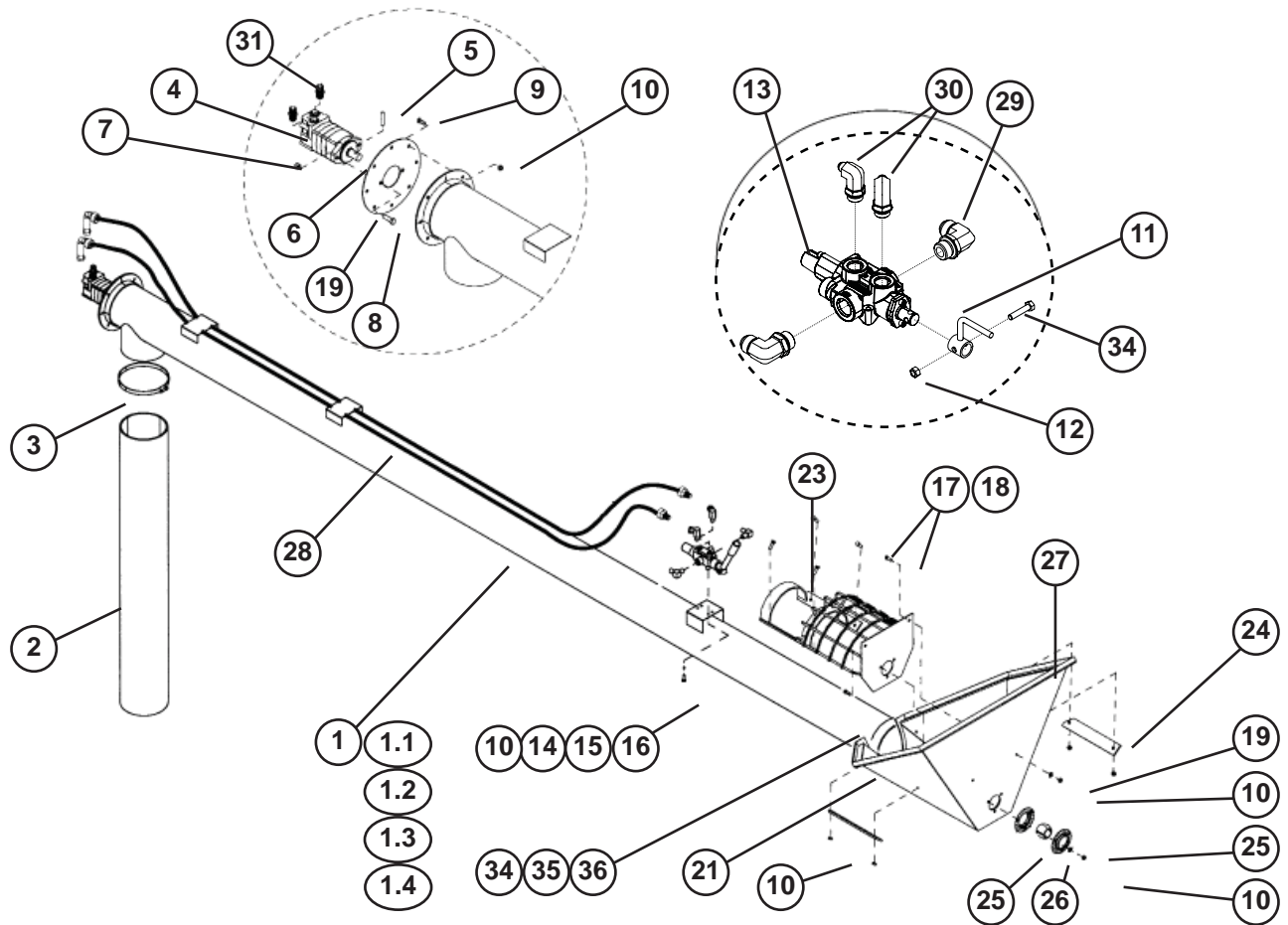

ASSY-AUGER & HYDRAULICS (8"/10")

Ref.	Part No.	Description	Qty.
1	65719	ASSY-AUGER 8.00" X 18'	1
	66101	ASSY-AUGER 10"	1
1.1	65903	POLY FLIGHTING: 7.00" X 18'	1
	66104	POLY FLIGHTING: 9.00" X 21'	1
1.2	65906	TUBE-AUGER: 8.00" X 18'	1
	66103	TUBE-AUGER: 10.00" X 21'	1
1.3	66259	POLY FLIGHTING: 7.00" X 6" LG - REPLACEMENT SECTION	REF
	66260	POLY FLIGHTING: 9.00" X 6" LG - REPLACEMENT SECTION	REF
1.4	66418	FLIGHTING-STEEL: 7.00' X 18'	1
	33582	FLIGHTING-STEEL: 9.00' X 21'	1
2	65714	HOSE-FLEX SPOUT 8" X 48"	1
	66102	HOSE-FLEX SPOUT 10"	1
3	66220	CLAMP-HOSE #152 (8")	1
	66256	CLAMP-HOSE #188 (10")	1
4	1032092	MOTOR-HYDRAULIC PAINTED	1
	1023837	SEAL-KIT: CHARLYNN 61258	
5	66079	BOLT-HEX: SS .375 X 2.75 NC	1
6	1033268	NUT-NYLOCK: .38 NC GR2 SS	1
7	65313	NUT-NYLOCK: .50 NC GR2 ZP	2
8	1011607	BOLT-HEX: .50 X 1.50 NC GR5 ZP	2
9	1011600	BOLT-HEX: .38 X 1.00 NC GR5 ZP	8
10	1013338	NUT-NYLOCK: .38 NC GR2 ZP	19
11	66107	HANDLE-AUGER VALVE ZP	1

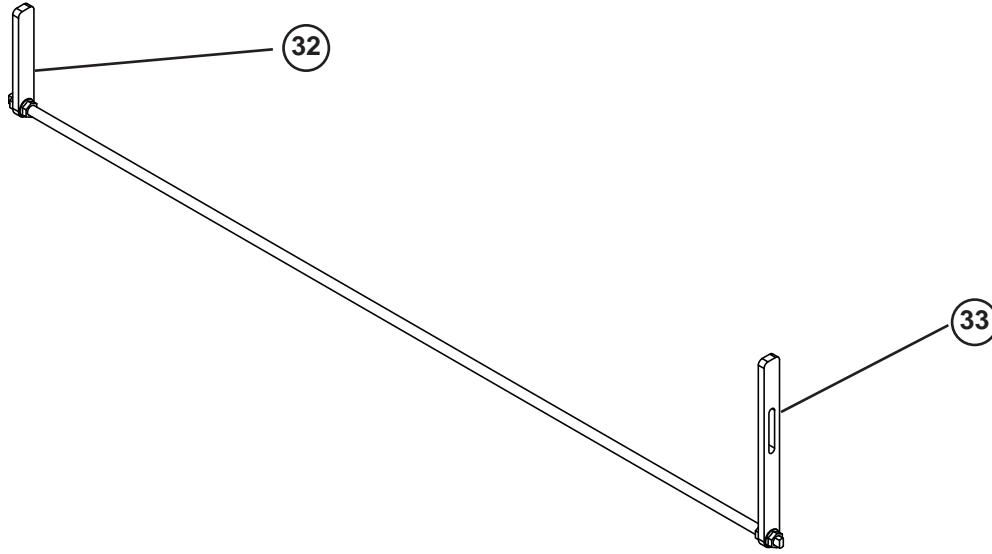

ASSY-AUGER & HYDRAULICS (8"/10") (continued)

Ref.	Part No.	Description	Qty.
12	58747	NUT-HEX: .31 NF GR5 ZP	2
13	65845	VALVE-CONTROL 4 WAY PAINTED	1
14	1019550	BOLT-HEX: .25 X 1.50 NC GR5 ZP	3
15	1013242	WASHER-LOCK: .25 ZP	3
16	1011587	NUT-HEX: .25 NC GR2 ZP	3
17	1011586	WASHER-LOCK: .38 ZP	4
18	1011601	BOLT-HEX: .38 X 1.25 NC GR5 ZP	4
19	1011828	WASHER-FLAT: .38 ZP	4
20	65723	HOSE KIT: AIR SYSTEM - REFERENCE	1
21	65907	HOPPER-POLY: 8"	1
	66277	HOPPER-POLY: 10"	1
22	65908	PLATE-MOTOR MOUNT: 8"	1
	66257	PLATE-MOTOR MOUNT: 10"	1
23	65912	MOUNT-HOPPER: 8"	1
	66258	MOUNT-HOPPER: 10"	1
24	65913	PLATE-BACKING	2
25	65914	BEARING-FLANGE	2
26	65915	BEARING-WOOD: 1.25	1
	33650	BEARING-WOOD: 1.50	1
27	65916	MESH-HOPPER: 8" (NOT SHOWN)	1
	66337	MESH-HOPPER: 10" (NOT SHOWN)	1
28	65896	HOSE-.50 X 156" 8FJX-8FJX-90	2
29	64060	FTG-ELBOW: 12MB-12MJ-90	2
30	65901	FTG-ELBOW: 10MB-8MJ-90	2
31	58195	FTG-ADAPT: 10MB-8MJ	2
32	66443	TOP HANDLE	1
33	66442	BOTTOM HANDLE	1
34	1014124	BOLT-HEX: .31 X 1.50 NC GR5 ZP	1
DECALS - REFERENCE PAGE 51			
34	65644	DECAL-DANGER	REF
35	65646	DECAL-WARNING	REF
36	65647	DECAL-DANGER	REF

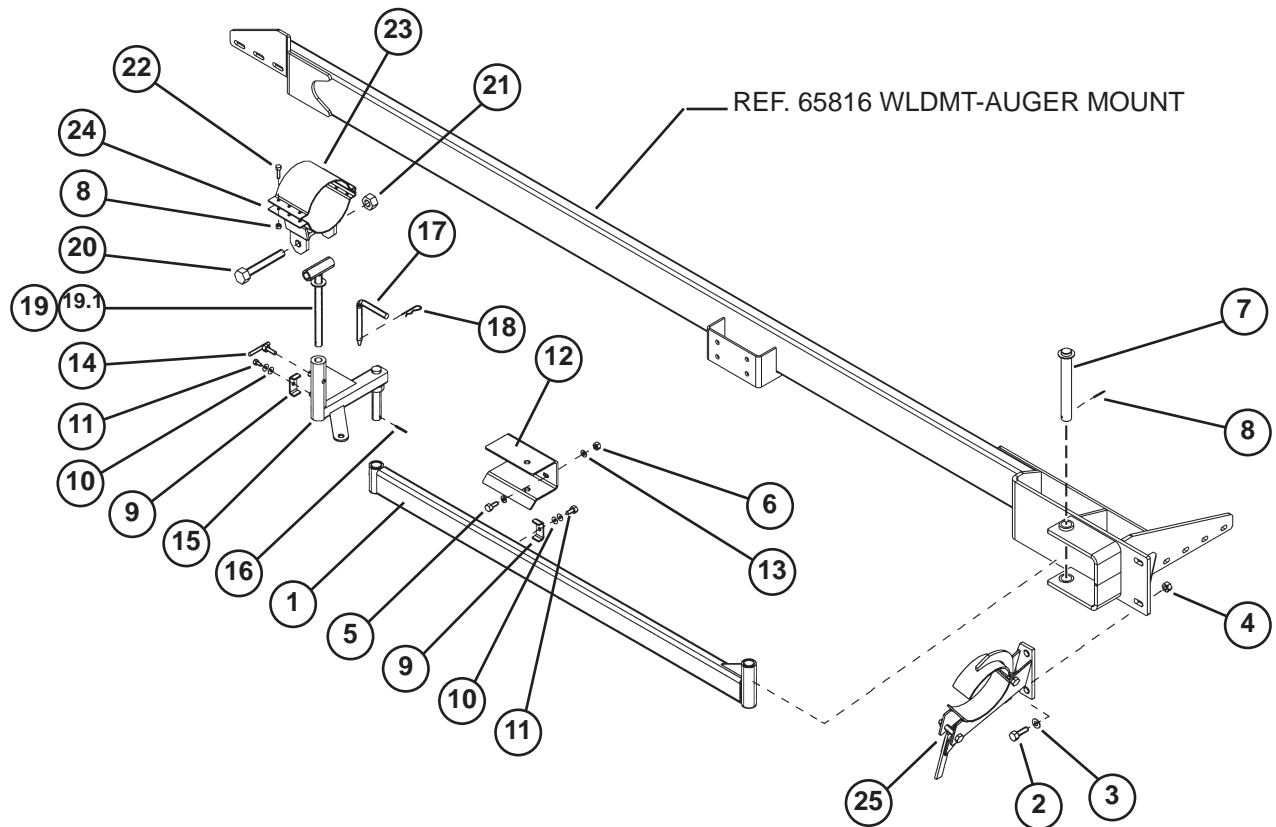

ASSY-AUGER MOUNTING COMPONENTS (8"/10")

Ref.	Part No.	Description	Qty.
1	65462	WLDMT-LONG AUGER MOUNT PAINTED	1
2	1011623	BOLT-HEX: .63 X 2.00 NC GR5 ZP	2
3	1013024	WASHER-FLAT: .63 ZP	4
4	1011578	NUT-HEX: .63 NC GR2 ZP	2
5	1011607	BOLT-HEX: .50 X 1.50 NC GR5 ZP	4
6	65313	NUT-NYLOCK: .50 NC GR2 ZP	10
7	65479	WLDMT-PIN	1
8	60965	PIN-ROLL: .19 X 1.50 ZP	1
9	50714	1023147 CLAMP 1/2" ZP	10
10	1011586	WASHER-LOCK: .38 ZP	3
11	1011600	BOLT-HEX: .38 X 1.00 NC GR5 ZP	3
12	65486	AUGER BRACKET-PAINTED	1
13	1014443	WASHER-FLAT: .50 ZP	10
14	65488	WLDMT-HANDLE	1
15	65468	WLDMT-ARM SHORT PAINTED	1
16	1011726	PIN-ROLL: .25 X 2.00 NP	2
17	65487	PIN-LOCK	1
18	1016115	PIN-HAIR: .19 X 3.25 ZP	1
19	65475	WLDMT-PIVOT TUBE	1
19.1	64505	GRIP-HANDLE RED 1" ID X 5.06" L	1
20	65721	BOLT-HEX: 1.00 X 7.00 NC GR5 ZP	1
21	65684	NUT-NYLOCK: 1.00 NC GR2 ZP	1
22	1011609	BOLT-HEX: .50 X 2.00 NC GR5 ZP	6
23	65909	CLAMP-TOP BRACKET: 8"	1
	66253	CLAMP-TOP BRACKET: 10"	1
24	65910	CLAMP-BOTTOM BRACKET: 8"	1
	66254	CLAMP-BOTTOM BRACKET: 10"	1
25	65911	ASSY-CLAMP: 8"	1
	66255	ASSY-CLAMP: 10"	1

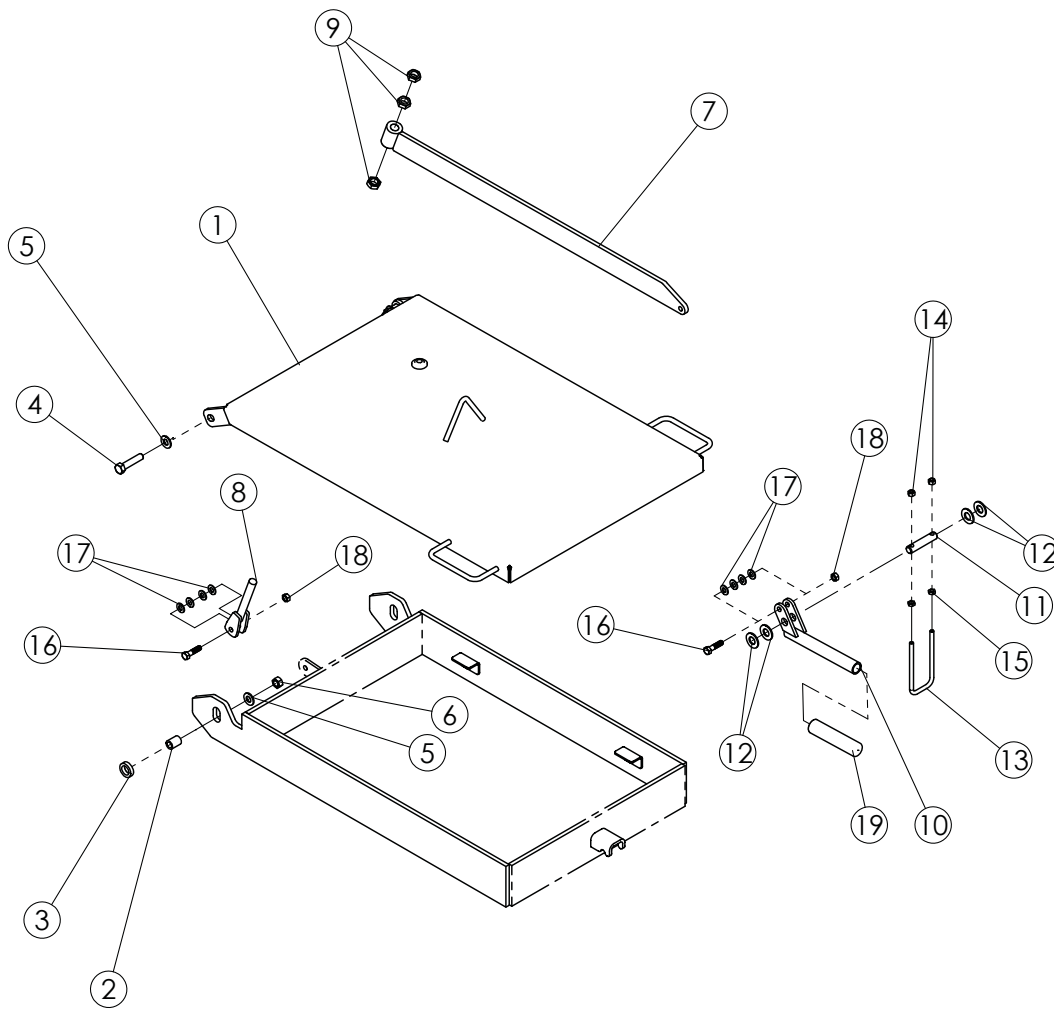

ASSY-DOORS

Ref.	Part No.	Description	Qty.
1	65558	WLDMT-TOP DOOR	1
2	65555	SPACER-DOOR HINGE	2
3	65554	SPACER-DOOR HINGE	2
4	1017708	BOLT-HEX: .50 X 2.25 NC GR5 ZP	2
5	1011584	WASHERPFLAT: SAE .50 ZP	4
6	1027461	NUT-TOPLOCK: .50 NC GR5 ZP	2
7	65559	WLDMT-CLAMP LEVER	1
8	65556	ROD-ADJUSTMENT ZP	1
9	1026259	NUT-JAM: .63 NC GR2 ZP	1
10	65557	WLDMT-CLAMP ADJ TUBE ZP	1
11	65560	PIIN-CLAMP LEVER	1
12	1013004	WASHER-FLAT: SAE .63 ZP	4
13	65656	U-BOLT: .313 X 5.00 X 2 X 5.00	1
14	1030700	NUT-TOPLOCK: .31 NC GR5 ZP	2
15	1020506	NUT-JAM: .31 NC GR2 ZP	4
16	1011602	BOLT-HEX: .38 X 1.50 NC GR5 ZP	2
17	1014608	WASHER-FLAT: SAE .38 ZP	8
18	1016999	NUT-TOPLOCK: .38 NC GR5 ZP	2
19	65902	GRIP-BLACK 1" ID X 5.06"L	1
20	64504	SEALANT-PROGLAZE (NOT SHOWN)	100
21	1026562	SCREEN BASKET	2

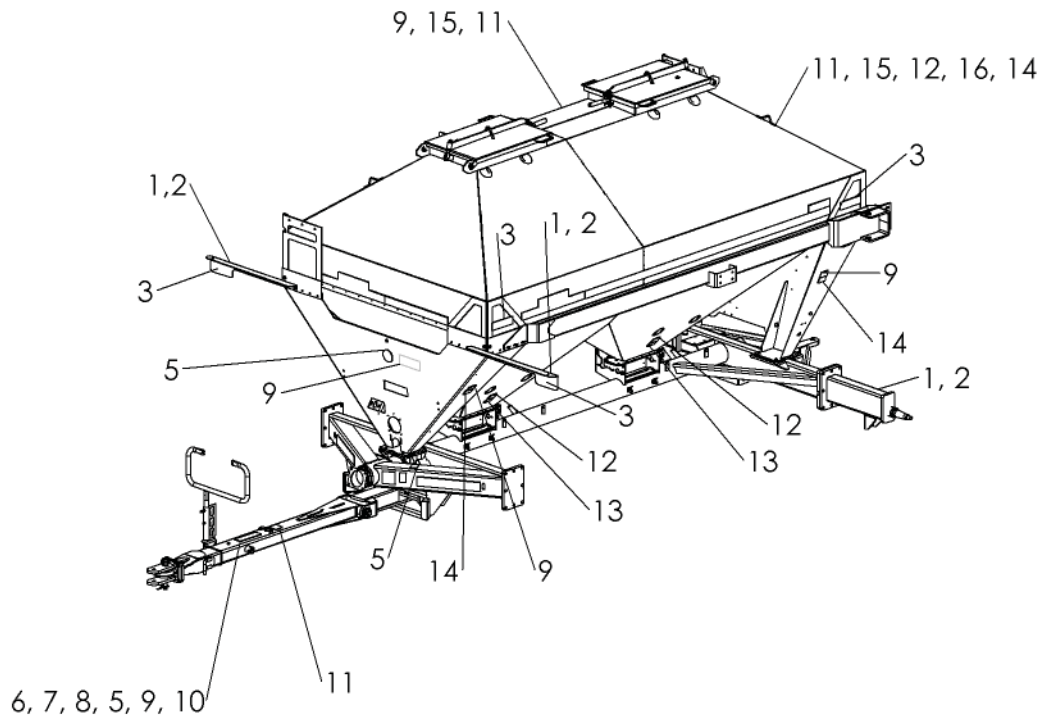

ASSY-DECALS AIR SYSTEM 2800 (3350)

Ref.	Part No.	Description	Qty.
1	997761	REFLECTOR, RED	4
2	997662	REFLECTOR ORANGE	4
3	997663	REFLECTOR YELLOW	6
4	9971009	SAFETY SIGN, SPEED SIGN, 30 km/h	1
5	997861	SAFETY SIGN, READ MANUAL	1
6	997857	SAFETY SIGN, FASTEN SAFETY CHAIN	1
7	997853	SAFETY SIGN, UNHITCHING HAZARD	1
8	997859	SAFETY SIGN, ENGINE OFF	1
9	997863	SAFETY SIGN, HIGH VOLTAGE	5
10	997867	SAFETY SIGN, FLUID UNDER PRESSURE	1
11	997840	SAFETY SIGN, CHEMICAL HAZARD	3
12	700732049	SAFETY SIGN, EXPLODING PARTS READ MANUAL	3
13	9971011	SAFETY SIGN, MOVING PART HAZARD	2
14	997841	SAFETY SIGN, CRUSHING HAZARD	3
15	9971015	SAFETY SIGN, FALL OFF HAZARD	2
16	700731523	SAFETY SIGN, HOT SURFACE, HAND,	1

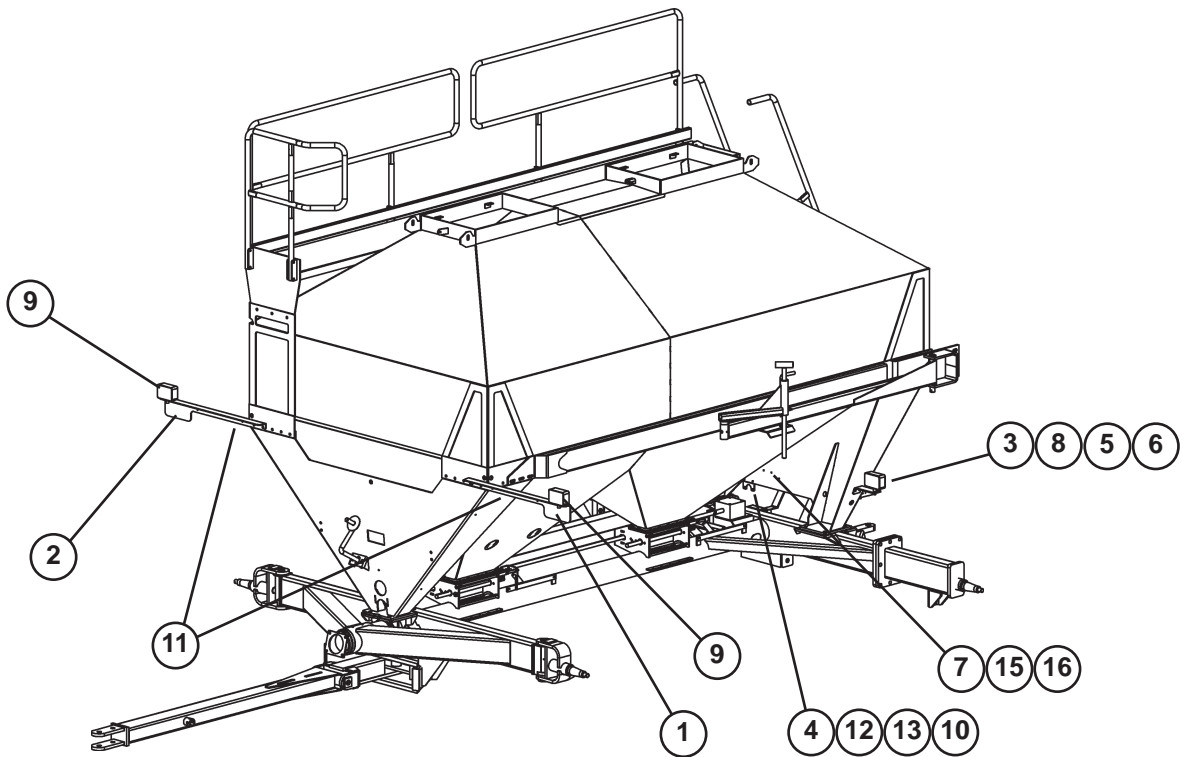

ASSY-SAFETY LIGHT

Ref.	Part No.	Description	Qty.
1	65831	BRACKET-LIGHT LH	1
2	65832	BRACKET-LIGHT RH	1
3	66011	BRACKET-LIGHT	2
4	65833	BRACKET-CONNECTOR 7 PIN	1
5	1033271	BOLT-HEX: .38 X 1.00 NC GR5 SS	4
6	1033268	NUT-NYLOCK: .38 NC GR2 SS	4
7	65341	MODULE-INTERFACE	1
8	65333	LAMP-RED TAIL	2
9	65334	LAMP-AMBER FLASHING	2
10	65340	HARNESS-SAFETY LIGHT S279.11	1
11	65354	HARNESS-LIGHT EXTENSION	2
12	1011598	BOLT-HEX: .31 X 1.00 NC GR5 ZP	4
13	1018693	NUT-NYLOCK: .31 NC GR2 ZP	4
14	1013122	TIE-CABLE, NYLON 14.00"	20
15	65839	SCREW-PAN HEAD: #10-24 NC X .75 LG	4
16	65348	NUT-HEX: #10-24 NC	4