

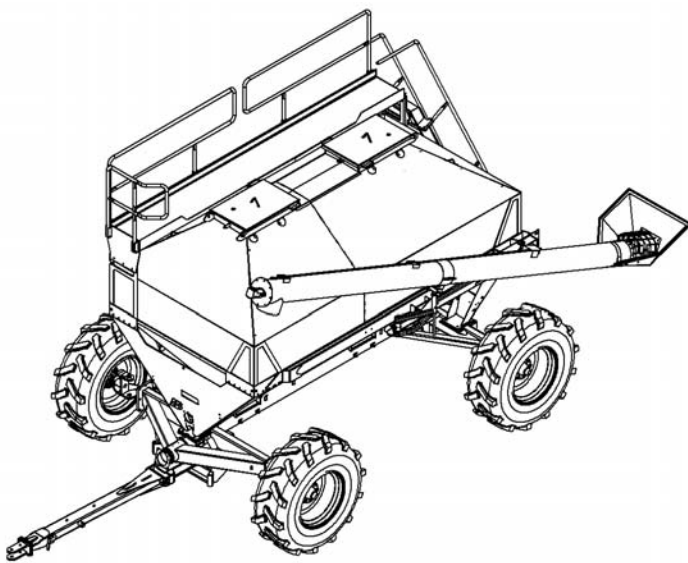

Operators Manual Air Systems



2800 / 3350

3800 / 5250

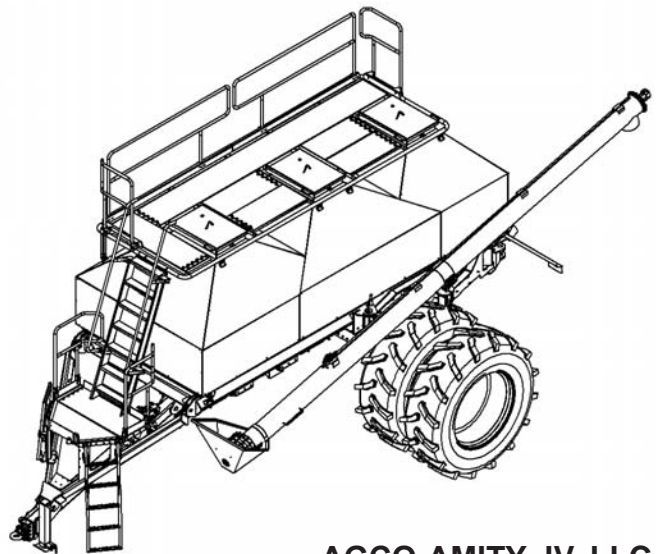

P/N: 331815
S/N: 702575

AGCO-AMITY JV, LLC
17885 Highway 13
Wahpeton, ND 58075 (800)
688-3300
(701) 642-2621
www.concordseeding.com

AMITY TECHNOLOGY, LLC LIMITED WARRANTY FOR NEW PRODUCTS

- 1. General Provisions.** This Warranty shall apply to the original purchaser of (1) any new and unused machine manufactured by Amity Technology, LLC (“Amity”), and (2) any new and unused part which is manufactured by Amity for use in an Amity machine, jointly referred to as “Products,” whether such Product is purchased through a dealer or directly from Amity. Under this Warranty, Amity will repair or replace, as it chooses in its sole discretion, any covered Product, or any component thereof, which Amity determines to be defective. This Warranty shall be in effect for a period of twelve (12) months (“the Warranty Period”), beginning on the date of delivery of the covered machine or part by the dealer or Amity to the purchaser (“the Warranty Start Date”). The purchaser must pay the cost of transportation of a Product to be repaired or replaced to and from an authorized Amity dealer. This Warranty may not be transferred from the original purchaser of a Product to any other person. This Warranty does not give a purchaser the right to any relief other than repair or replacement of the Product, and it specifically does not allow for consequential or incidental damages, exemplary or punitive damages, or costs and fees.
- 2. Scope and Limitations of Warranty.** With respect to machines, this Warranty is void if any part not supplied by Amity is used in assembly or repair of the machine, or if the machine has been altered, abused or neglected, as determined by Amity. With respect to parts, this Warranty is void if the part is used in any manner other than that for which it is intended. This Warranty does not extend in any way to tires and any other component of a Product warranted by another manufacturer, a copy of which warranty is provided herewith (“Third-Party Warranties”). In the event Amity determines that a Product is not defective, or that any other provision of this Paragraph 2 operates to limit the Warranty, this Warranty shall not apply and the purchaser shall be responsible for transporting the Product from the authorized Amity dealer’s location within 10 days of notice by Amity.
- 3. Procedures for Obtaining Service.** To secure Warranty service, a purchaser must (1) report the defect to an authorized dealer and request repair within 45 days of the failure and within the Warranty Period; (2) present evidence that this Warranty applies to the Product; (3) present evidence of the Warranty Start Date; and (4) bring the Product to an authorized Amity dealer within a reasonable period of time after reporting the defect.
- 4. LIMITATION OF IMPLIED WARRANTIES AND OTHER REMEDIES.** To the extent allowed by law, neither Amity, its dealers, nor any company affiliated with Amity makes any warranties, representations, or promises as to the quality, performance, or freedom from defect of any Product covered by this Warranty.

AMITY HEREBY WAIVES, TO THE EXTENT APPLICABLE, ANY AND ALL IMPLIED WARRANTIES OF MERCHANTABILITY AND FITNESS FOR A PARTICULAR PURPOSE. A PURCHASER’S ONLY REMEDIES IN CONNECTION WITH THIS WARRANTY ARE THOSE SET FORTH ON THIS PAGE. IN NO EVENT WILL AMITY, ITS DEALERS, OR ANY COMPANY AFFILIATED WITH AMITY BE LIABLE FOR INCIDENTAL, CONSEQUENTIAL OR PUNITIVE DAMAGES.

Some states do not allow waivers of certain warranties, so the above waivers may not apply to you. You may also have other rights which vary from state to state.

- 5. No Dealer Warranty.** This is the exclusive warranty applicable to Amity Products. No dealer has any authority to make any other warranty, modify, limit, or expand the terms of this Warranty in any fashion, or make any representation or promise on behalf of Amity.
- 6. Dispute Resolution.** Any controversy or claim arising out of or relating to this Warranty must be settled by arbitration in Fargo, North Dakota, at a time and location designated by the arbitrator, but not exceeding 30 days after a demand for arbitration has been made, and may be conducted by electronic, video, or other technical means. Arbitration will be conducted by the American Arbitration Association in accordance with its Rules of Commercial Arbitration, and judgment upon the award rendered by the arbitrator may be entered in any court having jurisdiction thereof. The arbitrator will have the authority to order Amity to undertake a repair or replace any Product, at its election, if the arbitrator finds that this Warranty requires Amity to do so. The arbitrator will not have the authority to impose any other remedy against Amity, including without limitation consequential or incidental damages, exemplary or punitive damages, or costs and fees.

280 / 335 / 380 / 525 Bushel Air Carts

1 Safety	7
1.1 Introduction	9
1.1.1 Safety alert symbol	9
1.1.2 Safety messages	9
1.1.3 Informational messages	9
1.1.4 Safety signs	9
1.1.5 A word to the operator	10
1.1.6 This manual	11
1.2 Operation	12
1.2.1 Prepare for operation	12
1.2.2 General information	12
1.2.3 Personal protective equipment	13
1.2.4 Seat instructions	13
1.2.5 Shield and guards	14
1.2.6 Exhaust warning	14
1.2.7 Flying debris	15
1.2.8 Agricultural chemicals	15
1.3 Travel on public roads	16
1.4 Maintenance	18
1.4.1 General maintenance information	18
1.4.2 Fire prevention and first aid	19
1.4.3 High pressure leaks	20
1.4.4 Tire safety	21
1.4.5 Replacement parts	21
1.5 Marker lamps	22
1.6 Safety sign location	23
2 Introduction	37
2.1 Introduction	39
2.1.1 Units of measurement	39
2.1.2 Replacement parts	39
2.1.3 Intended use	39
2.1.4 Proper disposal of waste	39
2.2 Machine identification	41
2.2.1 Serial number plate	41
2.2.2 Serial number description	41
2.3 Air cart	43
2.4 Major components	44
2.5 Two-bin operator manual	46
2.5.1 Operator manual storage	46
2.6 Three-bin operator manual	47
2.6.1 Operator manual storage	47
3 Operation	49
3.1 Ladder and railings	51
3.1.1 Ladder and railings - two-bin model	51
3.1.2 Ladder and railings - three-bin model	51
3.2 Product bin lids	52
3.3 Auger	53

3.3.1	Using the auger to load products	53
3.3.2	Using the auger to unload products	55
3.3.3	Cleaning out the auger	55
3.4	Ground drive	56
3.5	Hydraulic systems	57
3.5.1	Air cart to drill hydraulic coupler	57
3.5.2	Air cart to tractor hydraulic couplers	57
3.6	Hydraulic drive	59
3.7	Blower	60
3.7.1	Blower speed	60
3.8	Selecting air stream	61
3.9	Meters	62
3.9.1	Product meter adjustment	62
3.9.2	Changing metering rolls - ground drive system	63
3.9.3	Changing metering rolls - hydraulic system	63
3.9.4	Meter roll options	64
3.9.5	Meter adjustments	64
3.9.5.1	Shims	64
3.9.5.2	Deflector block	64
3.9.5.3	Meter door and cleanout door latches	65
3.9.5.4	Meter door tray	65
3.10	Setting the application rate on a ground drive system	66
3.11	Hydraulic drive calibration and operation	68
3.11.1	Preparing to calibrate a meter	68
3.11.2	Priming the meter	69
3.11.3	Taking a product sample for calibration	70
3.11.4	Entering accumulated weight on the virtual terminal	70
3.11.5	Manually setting the motor cal value for a variable rate system	71
3.12	Rate charts	72
3.12.1	Fertilizer rate chart - 96 kg per cubic meter (60 lb per cubic foot)	72
3.12.2	Barley rate chart	74
3.12.3	Canola rate chart	76
3.12.4	Soybean rate chart	78
3.12.5	Wheat rate chart	80
3.13	Raven system	82
3.13.1	Raven system overview	82
3.13.2	Raven system hardware	82
3.13.2.1	Raven electronic control unit	82
3.13.2.2	Virtual terminal	82
3.13.2.3	Blower speed sensor	82
3.13.2.4	Bin level sensor	83
3.13.2.5	Meter box flow sensor	83
3.13.2.6	Meter shaft speed sensor (ground drive)	83
3.13.2.7	Meter shaft speed sensor (hydraulic drive)	84
3.13.2.8	Ground speed sensor	84
3.14	Cart control system	85
3.14.1	Virtual terminal - cart control system	85
3.14.2	Alarm and indicator icons	85
3.14.3	Confirmation screen	86
3.14.4	Main (home) screen	87
3.14.5	Product bin alarms	89
3.15	Profile set up	90
3.15.1	Profile Set Up (Ground Drive).	96
3.15.2	Profile Set Up (Hydraulic Drive).	105
3.15.3	Master Switch Operation.	114
3.15.4	Enabling Automatic Height Switch	114

3.15.5	Manual Work Switch Operation	114
3.15.6	Setting the automatic height switch operation	114
3.15.7	Customizing Product Tabs.	115
3.15.8	Setting Test Speed	115
3.15.9	Refilling Product Bins.	115
4	Maintenance	116
4.1	Lubrication points	118
4.1.1	Lubrication and maintenance chart	118
4.1.2	Lubrication fitting locations	118
4.2	Hydraulic motor maintenance	120
4.3	Gear box maintenance	121
4.3.1	Replacing the gearbox coupler shear pin	121
4.4	Wheel bearing maintenance	122
4.5	Tires and wheels	123
4.6	Storing the air cart	124
5	Troubleshooting	113
5.1	Troubleshooting	128
6	Specifications	117
6.1	Specifications	130
6.1.1	Specifications - two-bin model	132
6.1.2	Specifications - three-bin model	132
6.1.3	Conversion factors	133
6.1.4	Formulas	134
6.2	Approximate tank fill percentages	135
6.3	Maximum transport speed	136
7	Index	138

1. Safety

1.1 Introduction	9
1.1.1 Safety alert symbol	9
1.1.2 Safety messages	9
1.1.3 Informational messages	9
1.1.4 Safety signs	9
1.1.5 A word to the operator	10
1.1.6 This manual	11
1.2 Operation	12
1.2.1 Prepare for operation	12
1.2.2 General information	12
1.2.3 Personal protective equipment	13
1.2.4 Seat instructions	13
1.2.5 Shield and guards	14
1.2.6 Exhaust warning	14
1.2.7 Flying debris	15
1.2.8 Agricultural chemicals	15
1.3 Travel on public roads	16
1.4 Maintenance	18
1.4.1 General maintenance information	18
1.4.2 Fire prevention and first aid	19
1.4.3 High pressure leaks	20
1.4.4 Tire safety	21
1.4.5 Replacement parts	21
1.5 Marker lamps	22
1.6 Safety sign location	23

1.1 Introduction

1.1.1 Safety alert symbol

The safety alert symbol means Attention! Become Alert! Your Safety Is Involved!

Look for the safety alert symbol both in this manual and on safety signs on this machine. The safety alert symbol will direct your attention to information that involves your safety and the safety of others.



Fig. 1

1.1.2 Safety messages

The words DANGER, WARNING or CAUTION are used with the safety alert symbol. Learn to recognize these safety alerts and follow the recommended precautions and safety practices.



DANGER:
Indicates an imminently hazardous situation that, if not avoided, will result in **DEATH OR VERY SERIOUS INJURY.**



WARNING:
Indicates a potentially hazardous situation that, if not avoided, could result in **DEATH OR SERIOUS INJURY.**



CAUTION:
Indicates a potentially hazardous situation that, if not avoided, may result in **MINOR INJURY.**



Fig. 2

1.1.3 Informational messages

The words important and note are not related to personal safety, but are used to give additional information and tips for operating or servicing this equipment.

IMPORTANT: *Identifies special instructions or procedures which, if not strictly observed, could result in damage to or destruction of the machine, process, or its surroundings*

NOTE: *Identifies points of particular interest for more efficient and convenient repair or operation.*

1.1.4 Safety signs



WARNING:
Do not remove or obscure safety signs. Replace any safety signs that are not readable or are missing. Replacement signs are available from your dealer in the event of loss or damage. The actual location of the safety signs is illustrated at the end of this section.

Keep signs clean by wiping off regularly. Use a mild soap and water solution if necessary.

If parts have been replaced or a used machine has been purchased, make sure all safety signs are present and in the correct location and can be read. Illustrations of safety sign locations are located at the rear of this section.

Replace any safety signs that can not be read, are damaged, or are missing. Clean the machine surface thoroughly with a mild soap and water solution before replacing signs. Replacement safety signs are available from your dealer.

1.1.5 A word to the operator

It is your responsibility to read and understand the safety section in this manual and the manual for all attachments before operating this machine. Remember you are the key to safety. Good safety practices not only protect you, but also the people around you.

Study the content in this manual and make the content a working part of your safety program. Keep in mind that this safety section is written only for this type of machine. Practice all other usual and customary safe working precautions, and above all remember - safety is your responsibility. You can prevent serious injury or death.

This safety section is intended to point out some of the basic safety situations that may be encountered during the normal operation and maintenance of your machine. This section also suggests possible ways of dealing with these situations. This section is not a replacement for other safety practices featured in other sections of this manual.

Personal injury or death may result if these precautions are not followed.

Learn how to operate the machine and how to use the controls properly.

Do not let anyone operate the machine without instruction and training.

For your personal safety and the personal safety of others, follow all safety precautions and instructions found in the manuals and on safety signs affixed to the machine and all attachments.

Use only approved attachments and equipment.

Make sure your machine has the correct equipment needed by the local regulations.

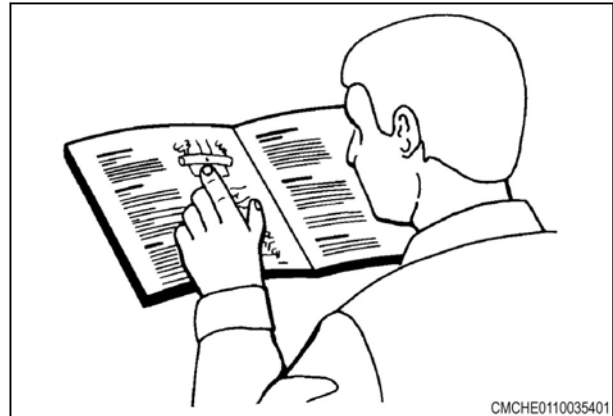

Fig. 3



WARNING:

An operator should not use alcohol or drugs which can affect their alertness or coordination. An operator on prescription or 'over the counter' drugs needs medical advice on whether or not they can properly operate machines.



CAUTION:
If any attachments used on this equipment have a separate Operator Manual, see that manual for other important safety information.

1.1.6 This manual

This manual covers general safety practices for this machine. The operator manual must always be kept with the machine.

Right-hand and left-hand, as used in this manual, are determined by facing the direction the machine will travel when in use.

The photos, illustrations, and data used in this manual were current at the time of printing, but due to possible in-line production changes, your machine can vary slightly in detail. The manufacturer reserves the right to redesign and change the machine as necessary without notification.



WARNING:
In some of the illustrations and photos used in this manual, shields or guards may have been removed for clarity. Never operate the machine with any shields or guards removed. If the removal of shields or guards is necessary to make a repair, they must be replaced before operation.

1.2 Operation

1.2.1 Prepare for operation

Read and understand all operating instructions and precautions in this manual before operating or servicing the machine.

Make sure you know and understand the positions and operations of all controls. Make certain all controls are in neutral and the park brake is applied before starting the machine.

Make certain all people are well away from your area of work before starting and operating the machine. Check and learn all controls in an area clear of people and obstacles before starting your work. Be aware of the machine size and have enough space available to allow for operation. Never operate the machine at high speeds in crowded places.

Emphasize the importance of using correct procedures when working around and operating the machine. Do not let children or unqualified persons operate the machine. Keep others, especially children, away from your area of work. Do not permit others to ride on the machine.

Make sure the machine is in the proper operating condition as stated in the Operator Manual. Make sure the machine has the correct equipment required by local regulations.

1.2.2 General information

When parking, park the machine and the tractor on a solid level surface. put all controls in neutral and apply the tractor park brake. Stop the tractor engine and take the key with you.

Make sure the tractor and implement are in the proper operating condition according to the operator manuals. Make sure the tractor brakes and the machine brakes are adjusted correctly.

The tractor must have enough weight and braking capacity, especially when operating on roads and terrain that is not even. Use a tractor of recommended size and weight to tow the machine. See the machine specifications for the minimum tractor size and weight.

Tractor must be equipped with rollover protective structure (ROPS) and a seat belt. use seat belt during operation.

Do not dismount from moving machinery.

Always operate the machine with the terminal turned on.

Never start the tractor with the PTO engaged or terminal turned on.

Stay off slopes too steep for operation.

Where possible avoid operating the machine near ditches, embankments, and holes. Reduce ground speed when operating on rough, slippery, or muddy surfaces and when turning or crossing slopes.

Be aware of the size of the machine and have enough space available to allow for operation.

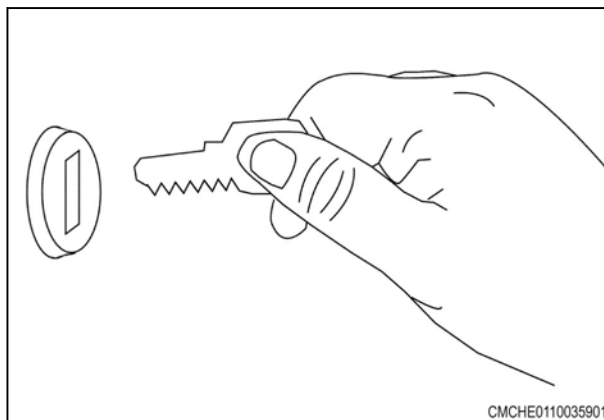

Fig. 4

Always lower the machine when not in use and relieve the pressure in the hoses and cylinders.

Do not stand between the tractor and the implement to install the hitch pin when the tractor engine is running.

Avoid contact with electrical power lines. Contact with electrical power lines can cause electrical shock, resulting in very serious injury or death.

Watch for overhead wires or other obstructions when raising the markers, and when moving the machine with the markers raised.

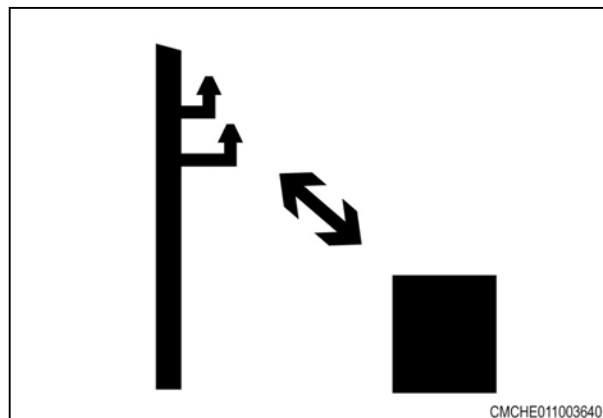

Fig. 5

1.2.3 Personal protective equipment

Wear all personal protective equipment (PPE) and protective clothing issued to you or called for by job conditions and country/local regulations. PPE includes, but is not limited to, equipment to protect eyes, lungs, ears, head, hands and feet when operating, servicing, or repairing equipment.

Always keep hands, feet, hair, and clothing away from moving parts. Do not wear loose clothing, jewelry, watches, or other items that could entangle in moving parts. Tie up long hair that can also entangle in moving parts.

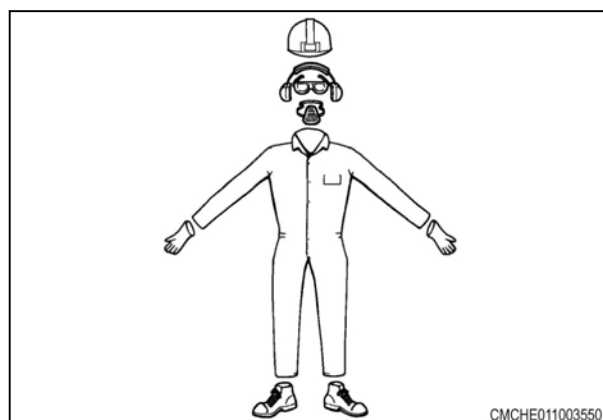

Fig. 6

1.2.4 Seat instructions

Securely fasten the seat belt before operating the machine. Always remain seated and have the seat belt fastened while operating the machine. Replace the seat belts when they become worn or broken.

Never wear a seat belt loosely or with slack in the belt system. Never wear the seat belt in a twisted condition or pinched between the seat structural members.

When using the instructional seat, if equipped, securely fasten the seat belt. The instructional seat is to be used only to train new operators or diagnose a problem. The instructional seat is only intended for short periods of use. Extra riders, especially children, are not permitted on the machine.

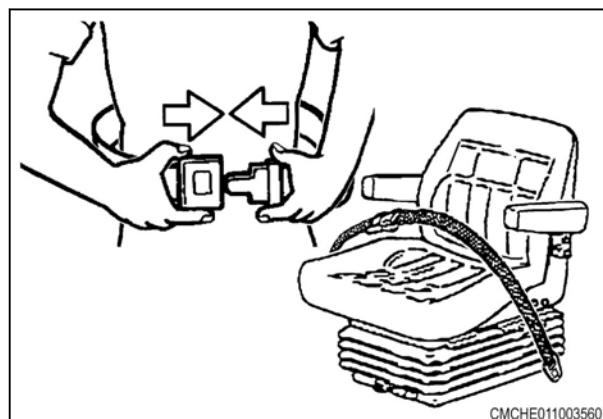

Fig. 7

When the instructional seat is used the machine must be driven at a slower speed and on level ground. Avoid quick starts, stops, and sharp turns. Avoid driving on highways or public roads.

1.2.5 Shield and guards

All shields and guards must be in the correct operating position and in good condition.

Do not open, remove, or reach around shields while the engine is operating. Entanglement in rotating belts and components can cause serious injury or death. Stay clear of rotating components.



Fig. 8

Do not operate the machine with the drive shaft shields open or removed. Entanglement in rotating drive shafts can cause serious injury or death. Stay clear of rotating components.

Make sure rotating guards turn freely.



Fig. 9

1.2.6 Exhaust warning

Never operate the engine in a closed building unless the exhaust is vented outside.

Do not tamper with or modify the exhaust system with unapproved extensions.

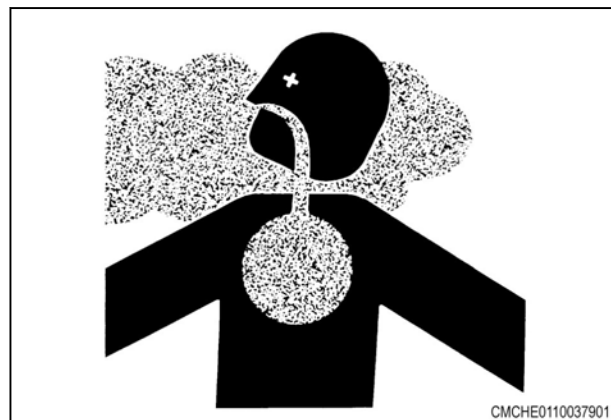

Fig. 10

1.2.7 Flying debris



WARNING:
Be careful when operating along the side of a road or building. Rocks or other debris can be thrown from the machine during operation possibly resulting in injury.

Never stand near the machine during operation. Debris can be thrown from the machine during operation possibly resulting in injury.



Fig. 11

1.2.8 Agricultural chemicals

Agricultural chemicals can be very hazardous. Improper use of fertilizer, fungicides, herbicides, insecticides and pesticides can injure people, plants, animals, soil and other people's property.

Always read and follow all manufacturers' instructions before opening any chemical container.

Even if you think you know the instructions, read and follow instructions each time you use a chemical.

Use the same precautions when adjusting, servicing, cleaning or storing the machine as used when installing chemicals into the hoppers or tanks.

Inform anyone who comes in contact with chemicals of the potential hazards involved and the safety precautions required.

Stand upwind and away from smoke from a chemical fire.

Store or dispose of all unused chemicals only in a manner as specified by the chemical manufacturer.

1.3 Travel on public roads

Make sure you understand the speed, brakes, steering, stability, and load characteristics of this machine before you travel on public roads.

Use good judgment when traveling on public roads. Maintain complete control of the machine at all times. Never coast down hills.

The maximum speed of farm equipment is governed by local regulations. Adjust travel speed to maintain control at all times.

Familiarize yourself with and obey all road regulations that apply to your machine. Consult your local law enforcement agency for local regulations regarding movement of farm equipment on public roads. Use head lamps, flashing warning lamps, tail lamps and turn signals, day and night, unless prohibited by local law.

Make sure all the flashers are operating prior to driving on the road. Make sure reflectors are correctly installed, in good condition, and wiped clean. Make sure the Slow Moving Vehicle (SMV) emblem is clean, visible, and correctly mounted on the rear of the machine.

Lock brake pedals together (if equipped with dual brake pedals) so both wheel brakes will be applied at the same time.

Raise implements to transport position and lock in place. Place all implements into narrowest transport configuration.

Disengage the power take-off and differential lock.

With towed implements, use a proper hitch pin with a clip retainer and safety transport chain.

Be aware of other traffic on the road. Keep well over to your own side of the road and pull over, whenever possible, to let faster traffic pass.

Be aware of the overall width, length, height, and weight of the machine. Be careful when transporting the machine on narrow roads and across narrow bridges.

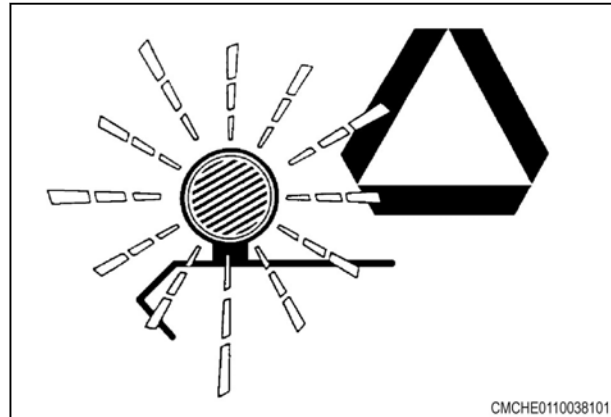

Fig. 12

Watch for overhead wires and other obstructions. Avoid contact with electrical power lines. Contact with electrical power lines can cause electrical shock, resulting in very serious injury or death.

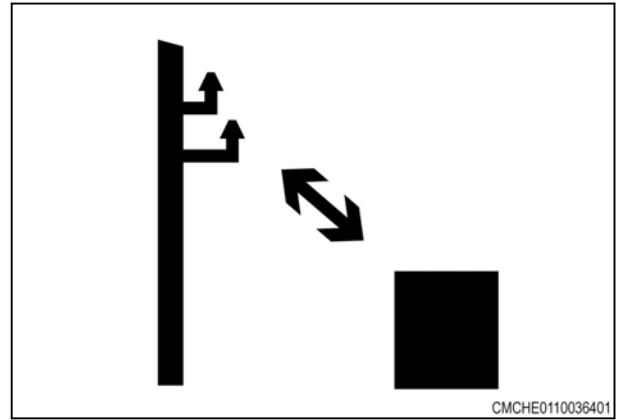

Fig. 13

1.4 Maintenance

1.4.1 General maintenance information

Before doing any unplugging, lubricating, servicing, cleaning, or adjusting:

- Park the machine on a solid level surface.
- Disengage the tractor power take-off.
- Make sure all controls are in the neutral position and apply the park brake.
- Make sure all implements and attachments have been lowered to the ground.
- Stop the engine and take the key with you.
- Look and Listen! Make sure all moving parts have stopped.
- Put blocks in front of and behind the wheels of the machine before working on or under the machine.

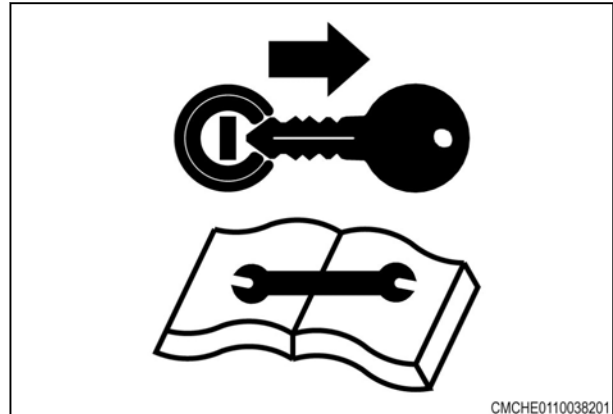

Fig. 14

Do not leave the tractor or implement unattended with the engine running.

Do not pull crop or any other object from the machine while the machine engine is running. Moving parts can pull you in faster than you can move away.

Check all nuts and bolts periodically for tightness, especially wheel mounting hardware.

Do not attempt to service or adjust the machine until all moving parts have stopped.

Be aware of the size of parts when doing service work. Never stand under or near a part being moved with lifting equipment.

After unplugging, lubricating, servicing, cleaning, or adjusting the machine make sure all tools and equipment have been removed.

Make sure electrical connectors are clean and free of dirt or grease before connecting.

Check for loose, broken, missing, or damaged parts. Make sure the machine is in good repair. Make sure all guards and shields are in position.

Always raise implement, shut off tractor engine, apply the parking brake, shift to park position (or neutral) remove the key and install the cylinder stops channels before working around the machine.

Avoid working under the machine. However, if it becomes unavoidable to do so, make sure the machine is securely blocked and the cylinder lockup channels are in position.

When working around discs, be careful to not get cut on sharp edges.

Never service, check or adjust drive chains or belts while the engine is running.



Fig. 15

Do not operate the machine with the drive shaft shields open or removed. Entanglement in rotating drive shafts can cause serious injury or death.

Stay clear of rotating components.

Make sure rotating guards turn freely.

A loose yoke can slip off a shaft and result in injury to persons or damage to the machine.

When installing a quick disconnect yoke, the spring activated locking pins must slide freely and be seated in the groove on the shaft. Pull on the driveline to make sure the quick disconnect yoke can not be pulled off the shaft.

Remove spilled oil, antifreeze or fuel immediately from the steps, platform, and other access areas.

Keep all access areas clean and free of obstructions.



CMCHE0110036801

Fig. 16



CMCHE0110119801

Fig. 17

1.4.2 Fire prevention and first aid

Be prepared for emergencies.

Keep a first aid kit handy for treatment of minor cuts and scratches.

Always carry one or more fire extinguishers of the correct type. Check fire extinguishers regularly as instructed by the manufacturer. Make sure fire extinguishers are properly charged and in operating condition.

Due to the nature of the crops this machine will operate in, the risk of fire is of concern. Use a water type fire extinguisher or other water source for a fire in crop.

For fires involving anything other than crop, such as oil or electrical components, use a dry chemical fire extinguisher with an ABC rating.

Mount fire extinguishers within easy reach of where fires can occur.

Frequently remove accumulated crop material from the machine and check for overheated components. Check the machine daily for any noises that are not normal. Such noises could indicate a failed component that can cause excess heat.

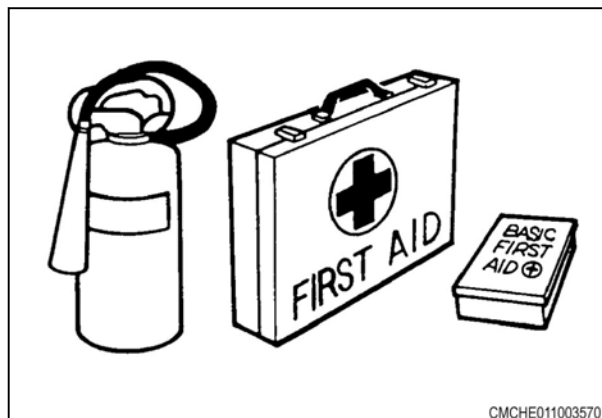

CMCHE0110035701

Fig. 18

If any flame cutting, welding, or arc welding is to be done on the machine or attachments, make sure to clear any crop material or debris from around the area. Make sure the area below the work area is clear of any flammable material as falling molten metal or sparks can ignite the material.

If fire occurs stand upwind and away from smoke from the fire.

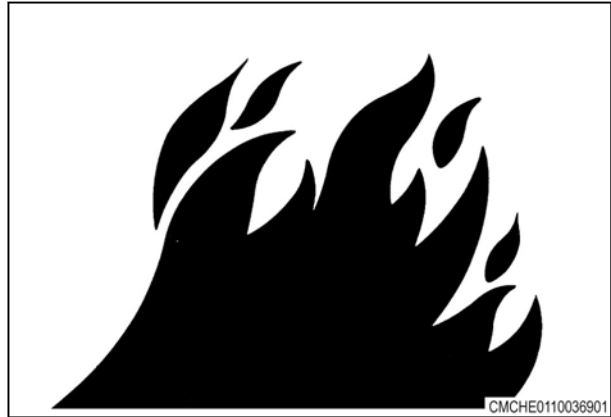

Fig. 19

1.4.3 High pressure leaks

Fluid leaking from the hydraulic system or the fuel injection system under high pressure can be very hard to see. The fluid can go into the skin causing serious injury.

Fluid injected into the skin must be surgically removed within a few hours. If not removed immediately, serious infection or reaction can develop. Go immediately to a doctor who knows about this type of injury.



Fig. 20

Use a piece of cardboard or wood to search for possible leaks. Do not use your bare hand. Wear leather gloves for hand protection and safety goggles for eye protection.

Relieve all pressure before loosening any hydraulic lines. Relieve the pressure by lowering raised equipment, shutting off accumulator valve, if equipped, and shutting off the engine. Tighten all connections securely before applying pressure.

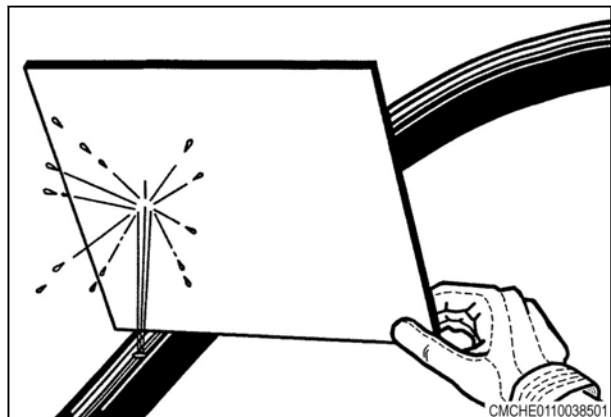

Fig. 21

1.4.4 Tire safety

Check tires for cuts, bulges, and correct pressure. Replace worn or damaged tires. When tire service is needed, have a qualified tire mechanic service the tire. Tire changing can be very hazardous and must be done by qualified tire mechanic using proper tools and equipment. See the Specifications Section for the correct tire size.

Tire explosion and/or serious injury can result from over inflation. Do not exceed the tire inflation pressures. See the Specifications Section for the correct tire pressure.

Do not inflate a tire that is seriously under inflated or has been run flat. Have the tire checked by qualified tire mechanic.

Do not weld on the rim when a tire is installed. Welding will make an air/gas mixture that can cause an explosion and burn with high temperatures. This danger applies to all tires, inflated or deflated. Removing air or breaking the bead is not enough. The tire must be completely removed from the rim prior to welding.



Fig. 22

1.4.5 Replacement parts

Where replacement parts are necessary for periodic maintenance and servicing, genuine replacement parts must be used to restore your equipment to original specifications.

The manufacturer will not accept responsibility for installation of unapproved parts and/or accessories and damages as a result of their usage.

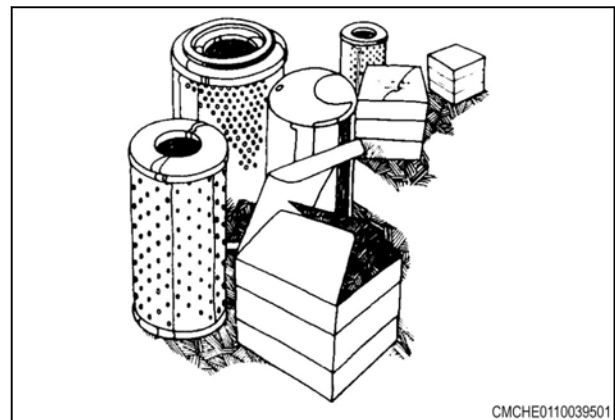

Fig. 23

1.5 Marker lamps

The machine is equipped with marker lamps and reflectors that must be used when transporting the machine on public roads.

The front of the machine is equipped with two amber lamps (1) located at the front.

The rear of the machine is equipped with a bar that has marker lamps (2) mounted at each end. Each lamp contains a yellow lens pointing toward the front and a red lens pointing toward the rear.

The machine is equipped with yellow reflectors mounted on the front and sides of the machine and red and orange reflectors mounted on the rear that must be visible when transporting the machine on public roads. See the safety sign location information for the location of these reflectors.

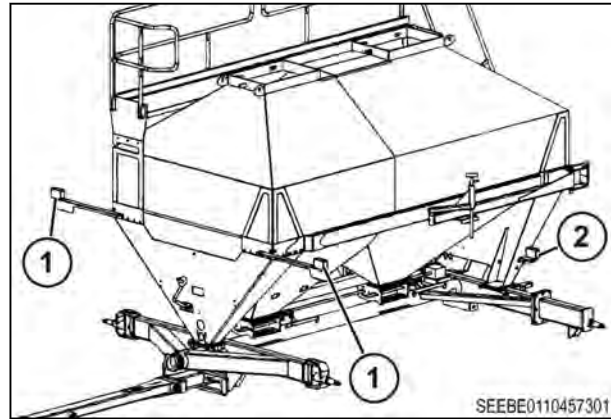

Fig. 24

1.6 Safety sign location

Two-bin model

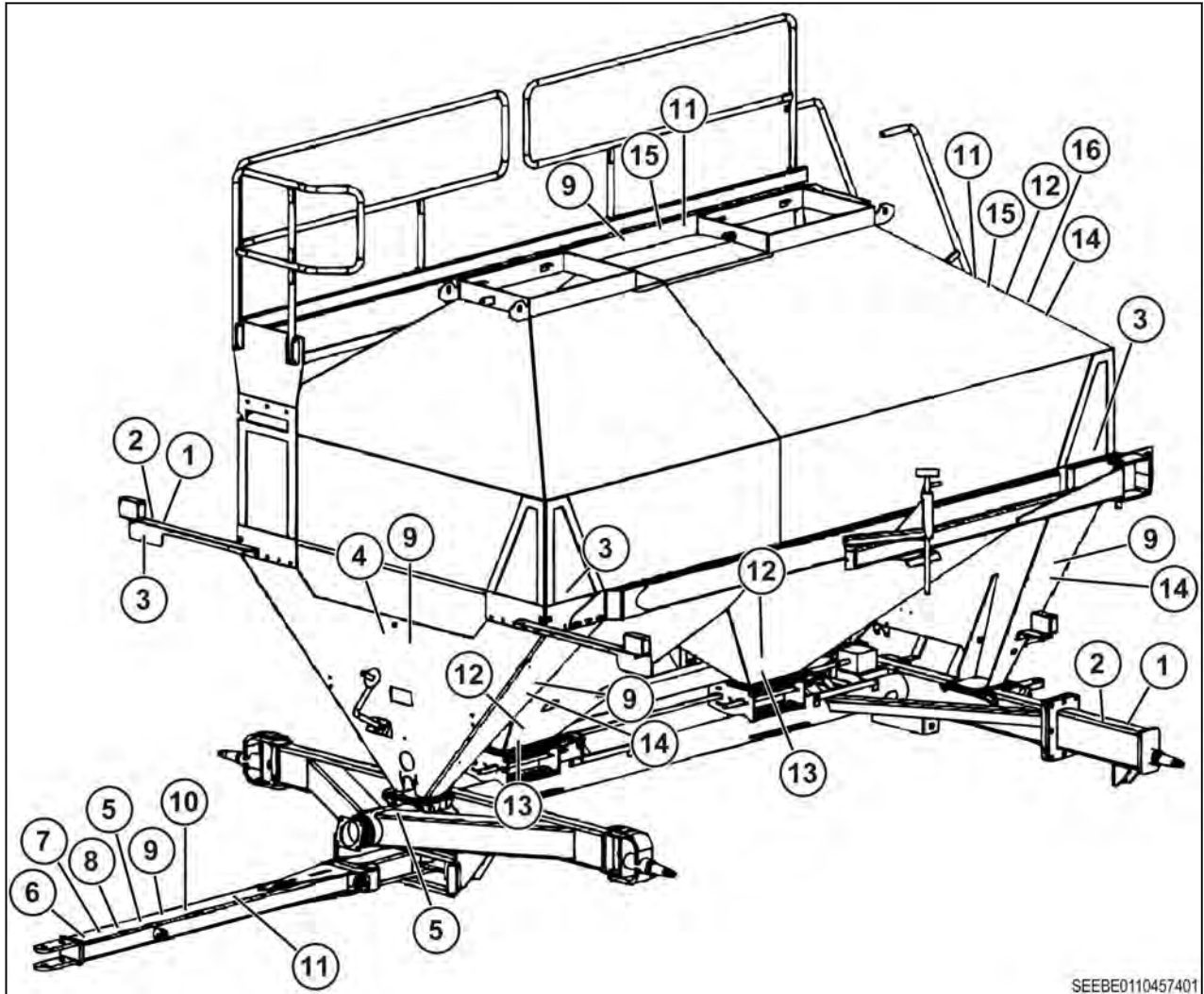

Fig. 25

Item	Reference number	Description
1	997661	Reflector, red
2	997662	Reflector, orange
3	997663	Reflector, yellow
4	9971018	Speed sign, 20 mph - North American models
	9971009	Speed sign, 30 km/h - Non-North American models
5	997861	Safety sign, read manual
6	997857	Safety sign, fasten safety chain
7	997853	Safety sign, unhitching hazard
8	997859	Safety sign, engine off
9	997863	Safety sign, high voltage
10	997867	Safety sign, fluid under pressure
11	997840	Safety sign, chemical hazard

Item	Reference number	Description
12	700732049	Safety sign-exploding parts read manual
13	9971011	Safety sign, moving part hazard
14	997841	Safety sign, crushing hazard
15	9971015	Safety sign, fall off hazard
16	700731523	Safety sign, safety sign-hot surface, hand

Most of the safety signs on this machine have two panels with few or no words. The hazard panel (A) depicts the hazard and the consequence of encountering the hazard. The avoidance panel (B) depicts the action required to avoid the hazard.

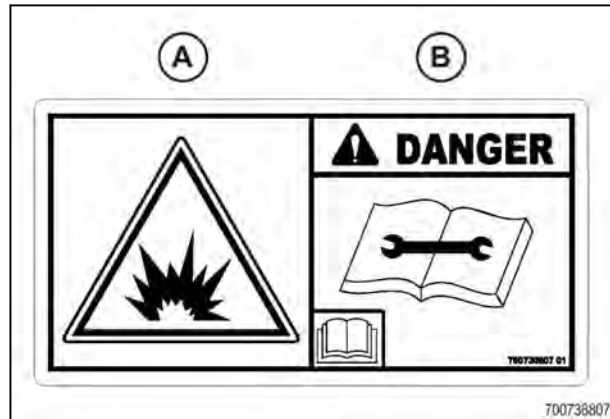

Fig. 26

Reflector, red (1)

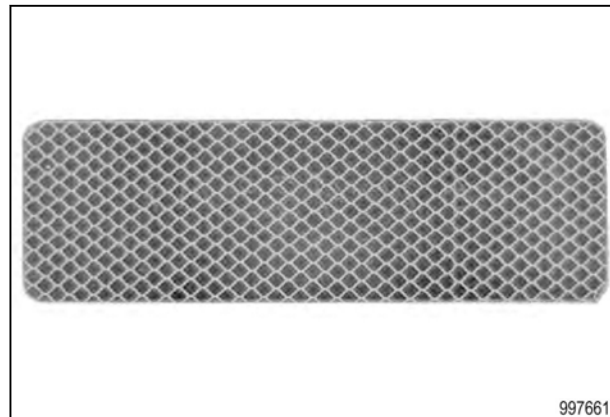

Fig. 27

Reflector, orange (2)

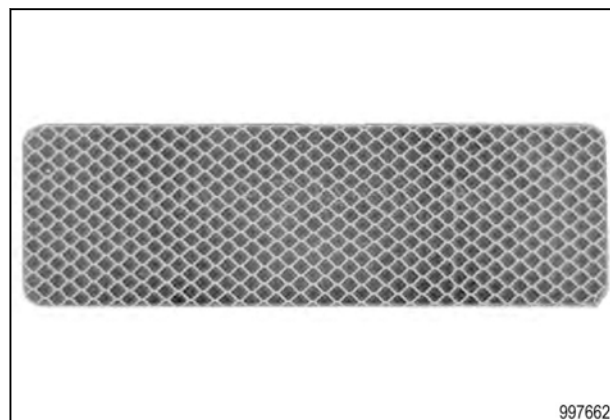

Fig. 28

Reflector, yellow (3)

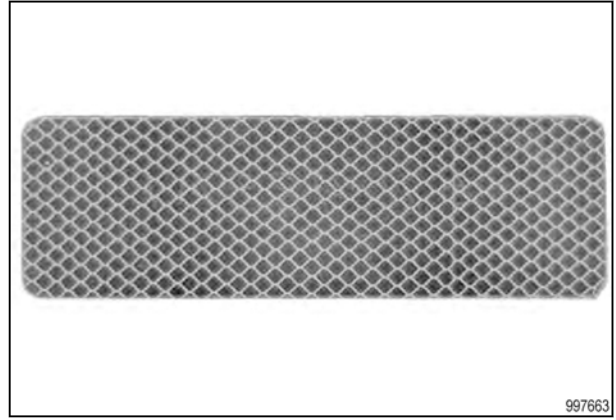

Fig. 29

North American models, safety sign, speed sign (4)

Do not exceed the maximum speed of 20 mph



Fig. 30

Non-North American models, safety sign, speed sign (4)

Do not exceed the maximum speed of 30 kph.



Fig. 31

Safety sign, read manual (5)

Hazard (A) - General safety alert

Avoidance (B) - Read and understand the Operator's Manual before operating the equipment. Follow safety and operating instructions.

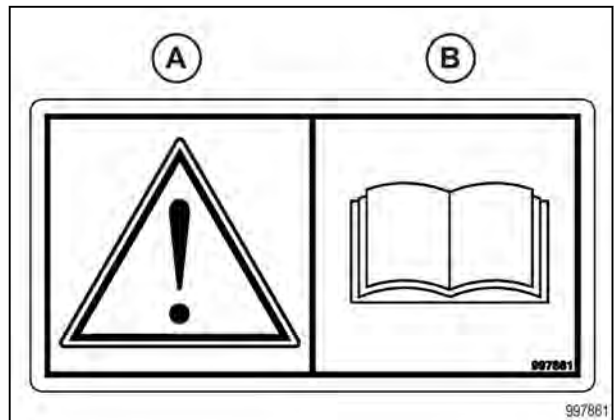

Fig. 32

Safety sign, fasten safety chain (6)

Hazard (A) - Loss of machine control

Avoidance (B) - Install the safety chains when attaching the implement to the tractor. Read the Operator Manual for safety information and operating instructions before operating the machine.

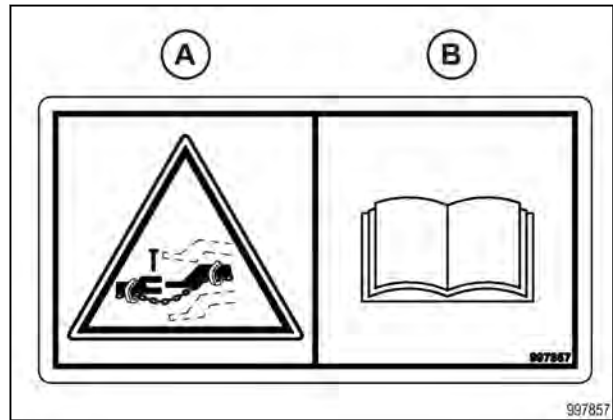

Fig. 33

Safety sign, unhitching hazard (7)

Hazard (A) - Negative tongue weight will cause immediate elevation of the tongue.

Avoidance (B) - Stay clear of the tongue when disconnecting the implement from the tractor. Read the Operator Manual for safety information and operating instructions before operating the machine.

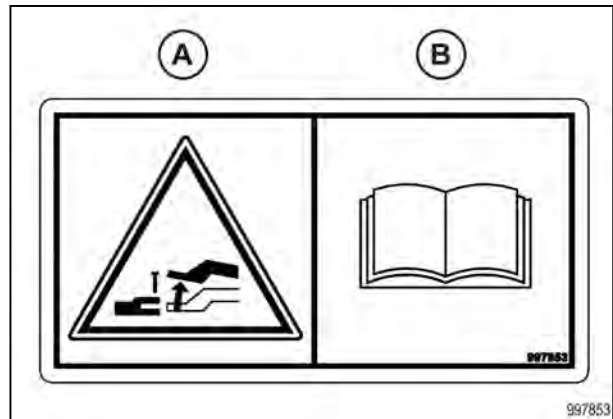

Fig. 34

Safety sign, engine off (8)

Hazard (A) - General safety alert

Avoidance (B) - Shut off engine and remove the key before performing maintenance or repair work.

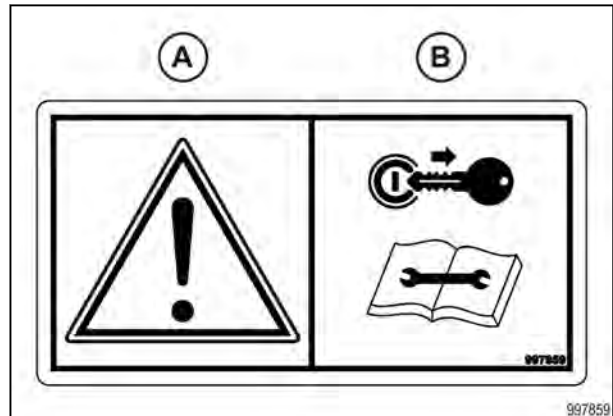

Fig. 35

Safety sign, high voltage (9)

Hazard (A) - Electrical shock hazard - risk of personal injury and component damage

Avoidance (B) - Keep sufficient distance away from electrical power lines.

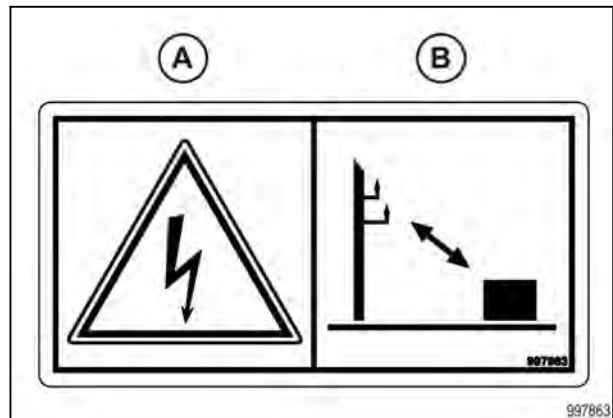

Fig. 36

Safety sign, fluid under pressure (10)

Hazard (A) - Injection hazard into skin - escaping fluid under high pressure

Avoidance (B) - Shut off engine, remove key, and relieve pressure before performing maintenance or repair work. Refer to the Operator Manual for proper service procedures.

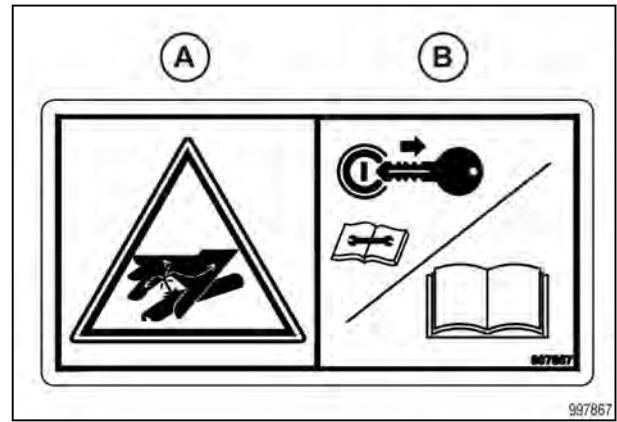

Fig. 37

Safety sign, chemical hazard (11)

Hazard (A) - Chemical injection hazard, lungs - opening the cover.

Avoidance (B) - Refer to the Operator's Manual and the chemical manufacturer's instructions.

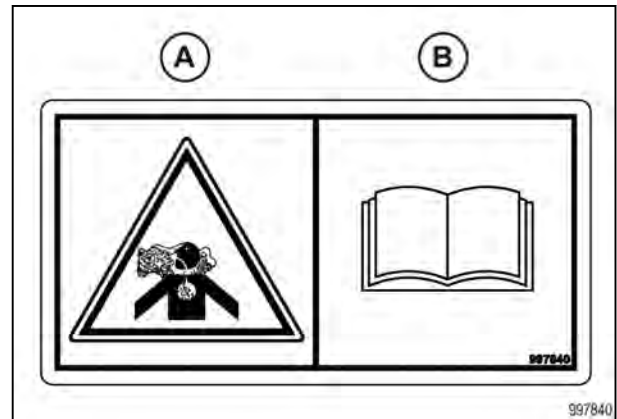

Fig. 38

Safety sign, thrown or flying object hazard (12)

Hazard (A) - Thrown or flying object hazard.

Avoidance (B) - Keep a safe distance. Read the Operator Manual for safety information and operating instructions before operating the machine.

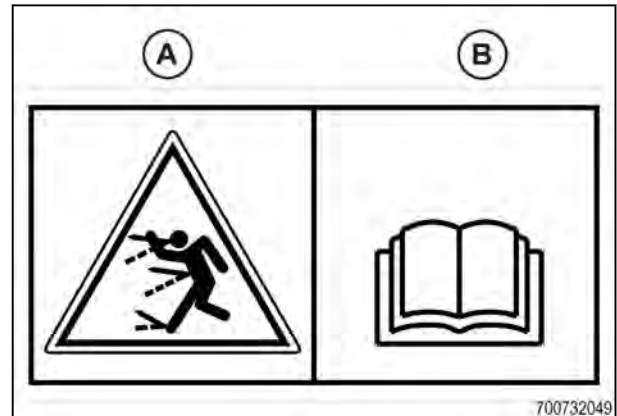

Fig. 39

Safety sign, moving part hazard (13)

Hazard (A) - Shearing hazard - finger shearing hazard - rotating components.

Avoidance (B) - Do not open, remove, or reach around shields while the engine is operating.

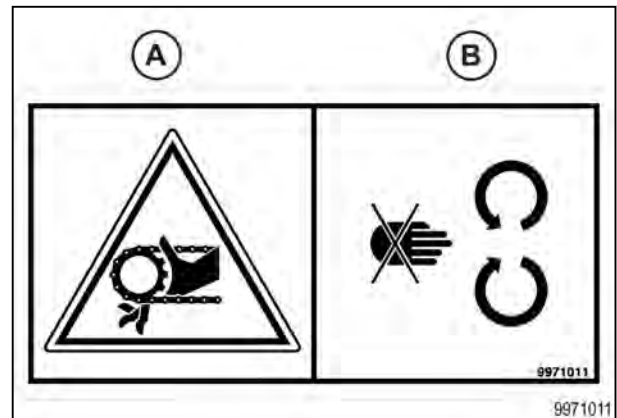

Fig. 40

Safety sign, crushing hazard (14)

Hazard (A) - Crushing hazard - risk of personal injury.

Avoidance (B) - Keep a safe distance from the machine while engine and machine are operating. Read the Operator Manual for safety information and operating instructions before operating the machine.

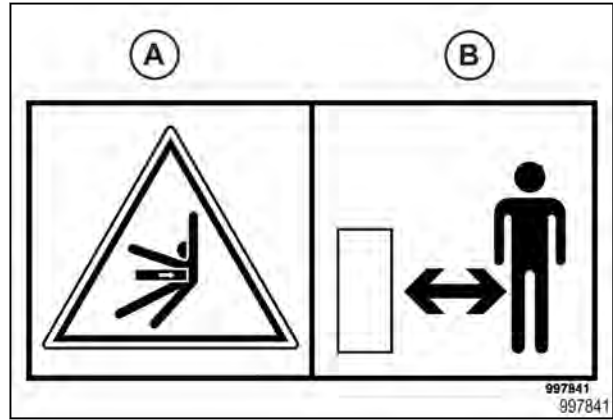

Fig. 41

Safety sign, fall off hazard (15)

Hazard (A) - Falling off hazard.

Avoidance (B) - Do not ride on the machine when it is operating or moving.

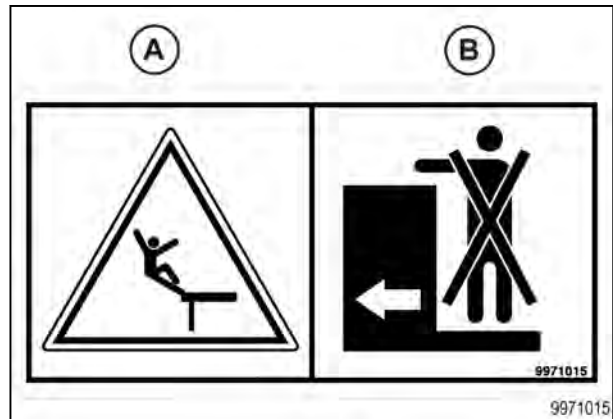

Fig. 42

Safety sign, hot surface, hand,(16)

Hazard (A) - Hand and finger burn hazard - hot surfaces.

Avoidance (B) - Stay clear and do not touch hot surfaces.



Fig. 43

Three-bin model

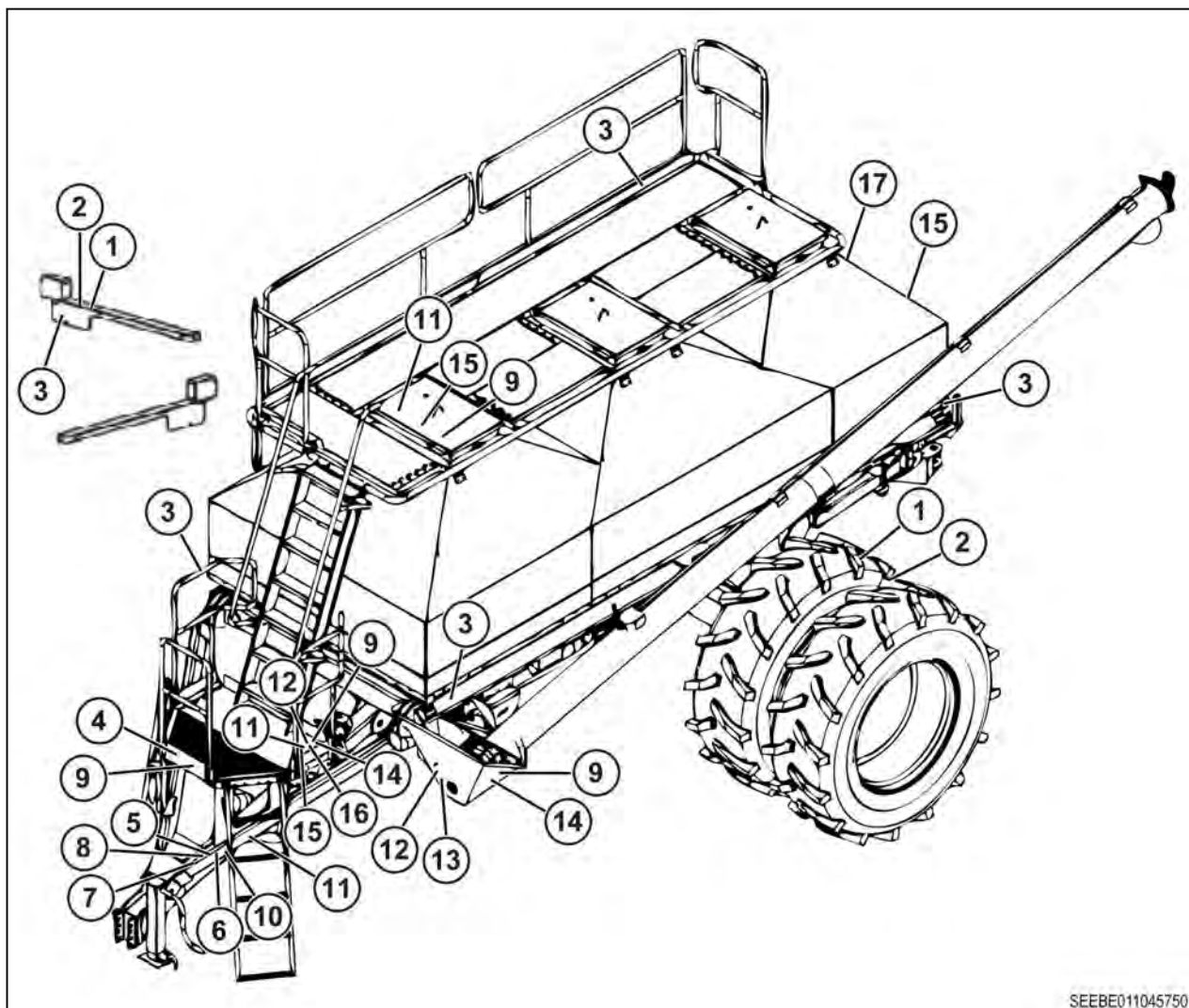

SEEBE0110457501

Fig. 44

Item	Reference number	Description
1	997661	Reflector, red
2	997662	Reflector, orange
3	997663	Reflector, yellow
4	9971009	Speed sign, 30 km/h
5	997861	Safety sign, read manual
6	997857	Safety sign, fasten safety chain
7	997853	Safety sign, unhitching hazard
8	997859	Safety sign, engine off
9	997863	Safety sign, high voltage
10	997867	Safety sign, fluid under pressure
11	997840	Safety sign, chemical hazard
12	700732049	Safety sign-exploding parts read manual
13	9971011	Safety sign, moving part hazard

Item	Reference number	Description
14	997841	Safety sign, crushing hazard
15	9971015	Safety sign, fall off hazard
16	700731523	Safety sign, safety sign-hot surface, hand
17	65329	SMV Emblem

Most of the safety signs on this machine have two panels with few or no words. The hazard panel (A) depicts the hazard and the consequence of encountering the hazard. The avoidance panel (B) depicts the action required to avoid the hazard.

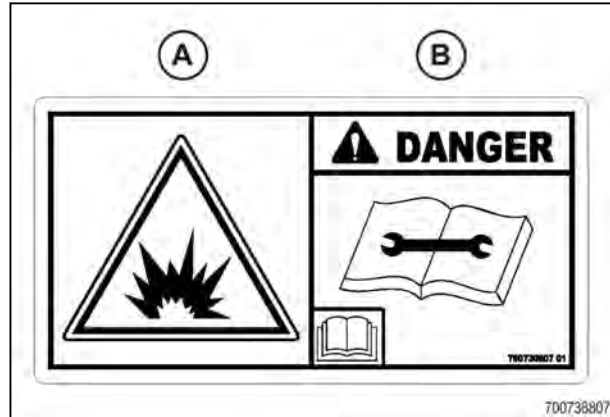

Fig. 45

Reflector, red (1)

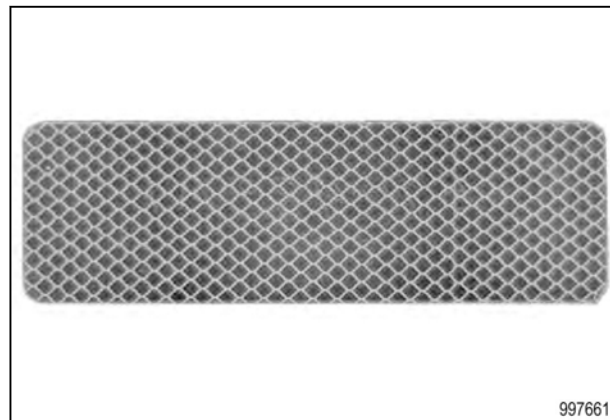

Fig. 46

Reflector, orange (2)

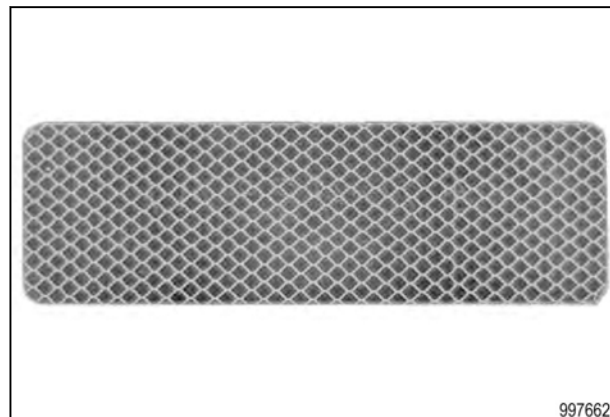

Fig. 47

Reflector, yellow (3)

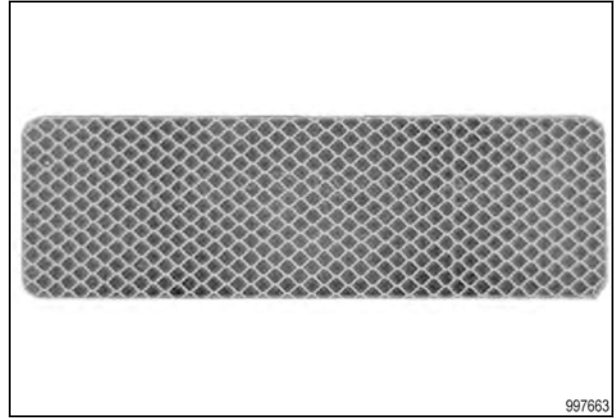

Fig. 48

North American models, safety sign, speed sign (4)

Do not exceed the maximum speed of 20 mph



Fig. 49

Non-North American models, safety sign, speed sign (4)

Do not exceed the maximum speed of 30 kph.



Fig. 50

Safety sign, read manual (5)

Hazard (A) - General safety alert

Avoidance (B) - Read and understand the Operator's Manual before operating the equipment. Follow safety and operating instructions.

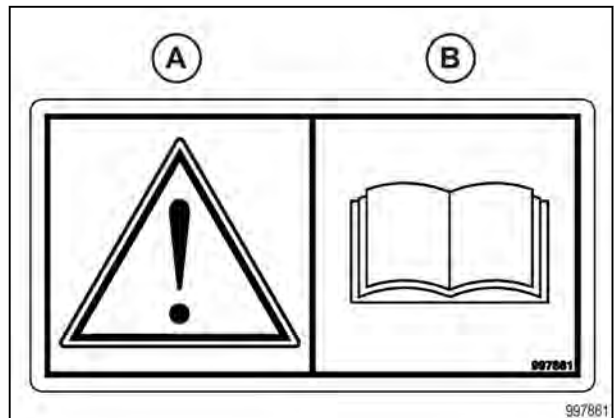

Fig. 51

Safety sign, fasten safety chain (6)

Hazard (A) - Loss of machine control

Avoidance (B) - Install the safety chains when attaching the implement to the tractor. Read the Operator Manual for safety information and operating instructions before operating the machine.

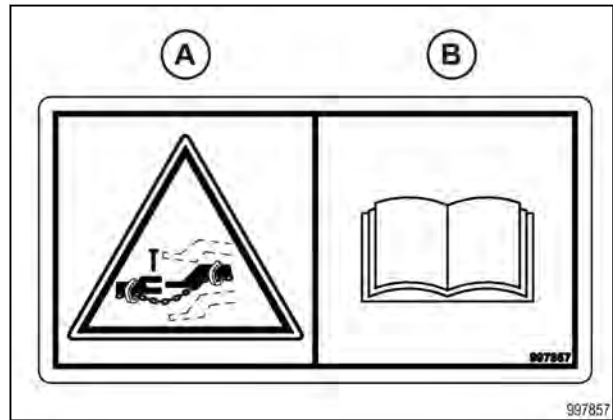

Fig. 52

Safety sign, unhitching hazard (7)

Hazard (A) - Negative tongue weight will cause immediate elevation of the tongue.

Avoidance (B) - Stay clear of the tongue when disconnecting the implement from the tractor. Read the Operator Manual for safety information and operating instructions before operating the machine.

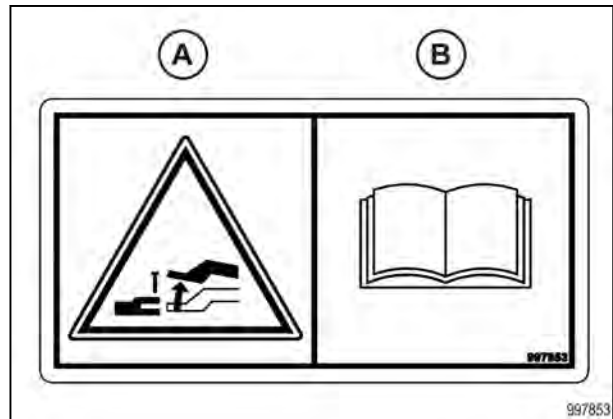

Fig. 53

Safety sign, engine off (8)

Hazard (A) - General safety alert

Avoidance (B) - Shut off engine and remove the key before performing maintenance or repair work.

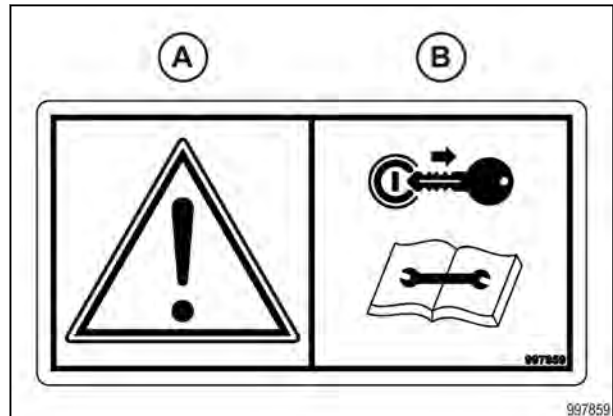

Fig. 54

Safety sign, high voltage (9)

Hazard (A) - Electrical shock hazard - risk of personal injury and component damage

Avoidance (B) - Keep sufficient distance away from electrical power lines.

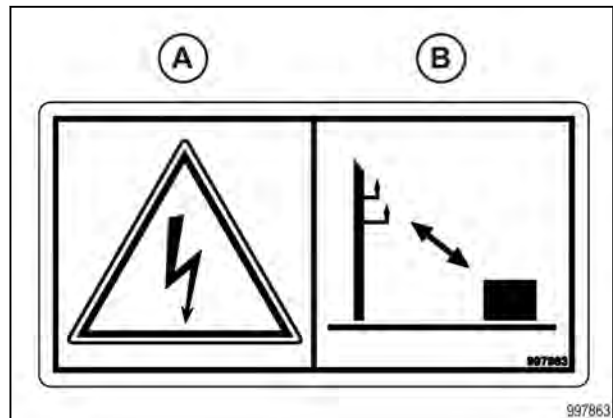

Fig. 55

Safety sign, fluid under pressure (10)

Hazard (A) - Injection hazard into skin - escaping fluid under high pressure

Avoidance (B) - Shut off engine, remove key, and relieve pressure before performing maintenance or repair work. Refer to the Operator Manual for proper service procedures.

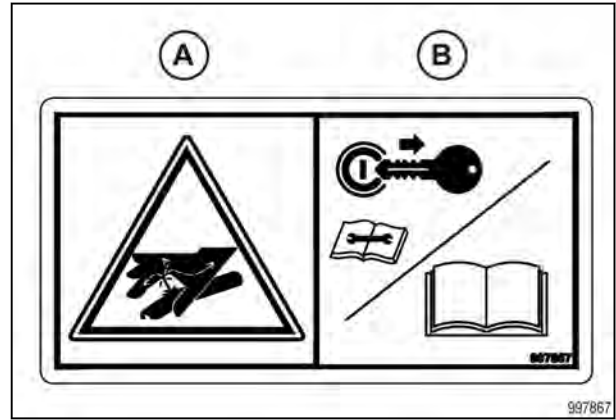

Fig. 56

Safety sign, chemical hazard (11)

Hazard (A) - Chemical injection hazard, lungs - opening the cover.

Avoidance (B) - Refer to the Operator's Manual and the chemical manufacturer's instructions.

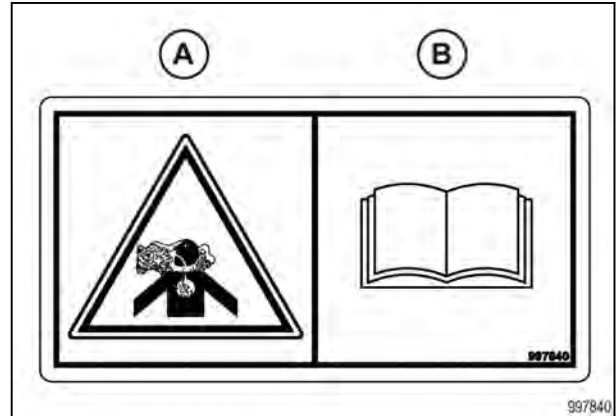

Fig. 57

Safety sign, thrown or flying object hazard (12)

Hazard (A) - Thrown or flying object hazard.

Avoidance (B) - Keep a safe distance. Read the Operator Manual for safety information and operating instructions before operating the machine.

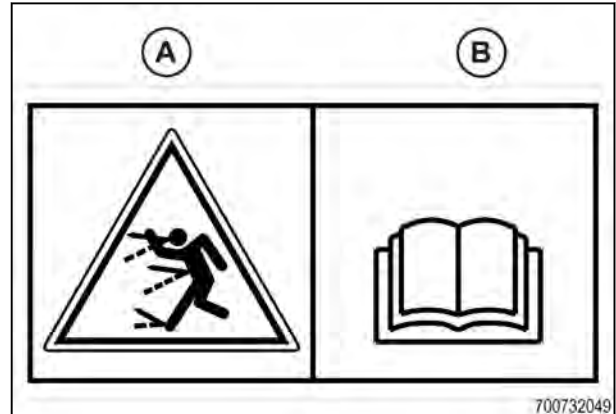

Fig. 58

Safety sign, moving part hazard (13)

Hazard (A) - Shearing hazard - finger shearing hazard - rotating components.

Avoidance (B) - Do not open, remove, or reach around shields while the engine is operating.

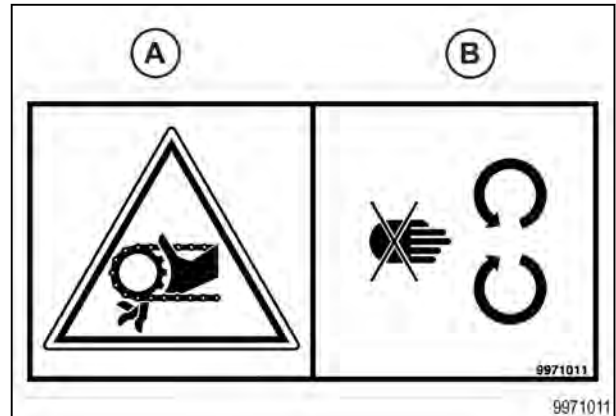

Fig. 59

Safety sign, crushing hazard (14)

Hazard (A) - Crushing hazard - risk of personal injury.

Avoidance (B) - Keep a safe distance from the machine while engine and machine are operating. Read the Operator Manual for safety information and operating instructions before operating the machine.

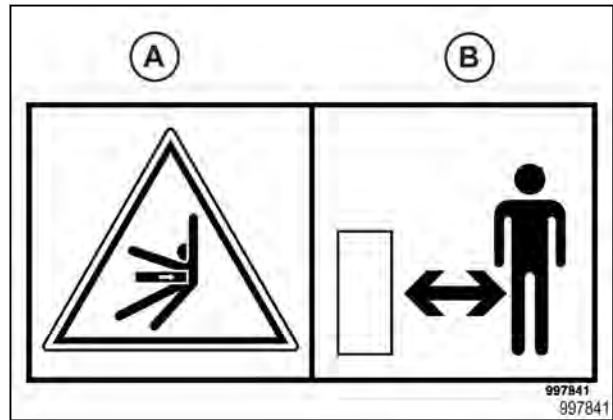

Fig. 60

Safety sign, fall off hazard (15)

Hazard (A) - Falling off hazard.

Avoidance (B) - Do not ride on the machine when it is operating or moving.

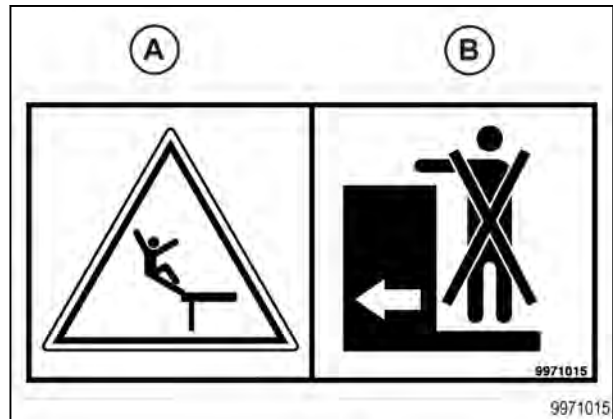

Fig. 61

Safety sign, hot surface, hand,(16)

Hazard (A) - Hand and finger burn hazard - hot surfaces.

Avoidance (B) - Stay clear and do not touch hot surfaces.



Fig. 62

SMV Emblem (17)

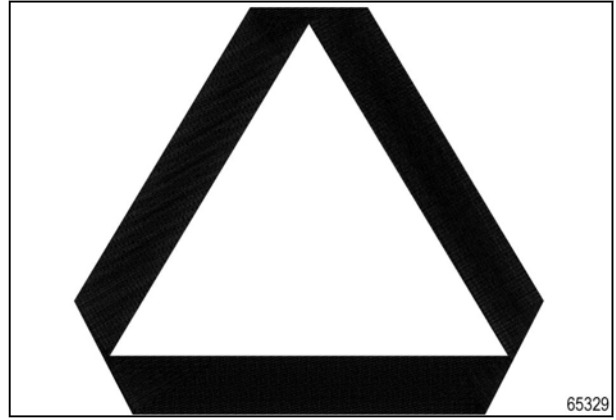

Fig. 63

2. Introduction

2.1 Introduction	39
2.1.1 Units of measurement	39
2.1.2 Replacement parts	39
2.1.3 Intended use	39
2.1.4 Proper disposal of waste	39
2.2 Machine identification	41
2.2.1 Serial number plate	41
2.2.2 Serial number description	41
2.3 Air cart	43
2.4 Major components	44
2.5 Two-bin operator manual	46
2.5.1 Operator manual storage	46
2.6 Three-bin operator manual	47
2.6.1 Operator manual storage	47

2.1 Introduction

**CAUTION:**

In some of the illustrations used in this Operator Manual, panels or guards may have been removed for clarity. Never operate the tractor with these panels and guards removed. If the removal of a shield is necessary to make a repair, it must be replaced before operation.

**CAUTION:**

Read this book in its entirety prior to operating machine. Use only genuine replacement parts for repairs and/or replacement.

This manual gives the operator the proper instructions needed for operation and maintenance. Read, understand, and follow these instructions for best machine performance and life. With proper maintenance and operation procedures, the machine will have better over all performance. Use normally available tools for maintenance on this machine.

All operators must read and understand this manual before operating this machine. Where possible, operators who have not operated the machine must receive instruction from an operator who has operated this machine. Your dealer can give instruction in machine operation. Keep this manual with the machine for future reference. If the original manual is damaged, order a replacement from your dealer.

See your dealer in for any service problems and adjustments. The dealer is equipped for all service work and to help with specific applications of the tractor in local conditions.

Left-hand and right-hand are determined by facing the direction the machine will travel when in use.

2.1.1 Units of measurement

Measurements are given in metric units followed by the equivalent in US units. Hardware sizes are given in millimeters for metric hardware and inches for US hardware.

2.1.2 Replacement parts

To receive prompt efficient service, remember to have the following information:

- Correct part description and part number
- Model number of the machine
- Serial number of the machine

2.1.3 Intended use

This machine is designed solely for use in customary agricultural operations.

Do not use this machine for any application or purpose other than those described in this manual. The manufacturer accepts no liability for damage or injury resulting from misuse of this machine.

Compliance with the conditions of operation, service and repair as specified by the manufacturer constitute essential elements for the intended use of this machine.

This machine should be operated, serviced and repaired only by qualified persons familiar with its characteristics and familiar with the relevant safety rules and procedures.

All generally recognized safety regulations and road traffic regulations must be obeyed at all times.

Any unauthorized modifications performed on this machine will relieve the manufacturer of all liability for any resulting damage or injury.

2.1.4 Proper disposal of waste

Improper disposal of waste can pollute the environment and ecology. A few examples of potentially harmful equipment waste can include, but not limited to, items such as oil, fuel, coolant, brake fluid, filters, battery chemicals, tires, etc.

Use leak proof containers when draining fluids. Do not use food or beverage containers to collect waste fluids, as food or beverage container(s) may mislead someone into drinking from them.

Do not pour or spill waste onto the ground, down a drain, or into any water source.

Air conditioning refrigerants escaping into the air can damage the Earth's atmosphere. Government regulations may require a certified air conditioning service center to recover and recycle used air conditioning refrigerants.

Inquire with local environmental or recycling center on the proper way to recycle or dispose waste.

2.2 Machine identification

Each machine is identified by a model and a serial number.

Record these numbers in the spaces given.

Give the model number and serial number to your dealer when parts or service are required.

Machine model number: _____

Machine serial number: _____

Date of delivery: _____

Dealer name: _____

Dealer address: _____

Dealer telephone number: _____

Dealer e-mail address: _____

Dealer fax number: _____

2.2.1 Serial number plate

For two-bin models, the serial number plate (1) is located on the rear hopper support.

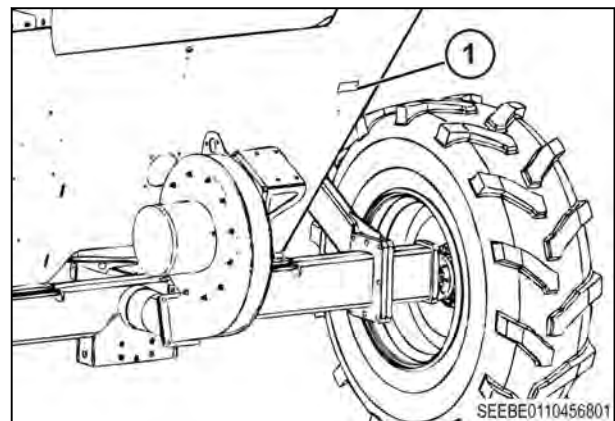

Fig. 1

For three-bin models, the serial number plate (1) is located on the frame.

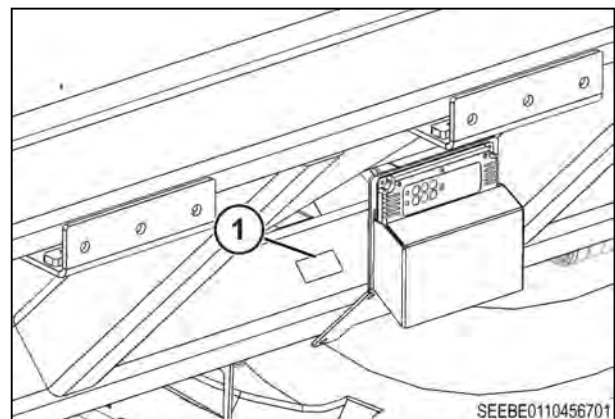
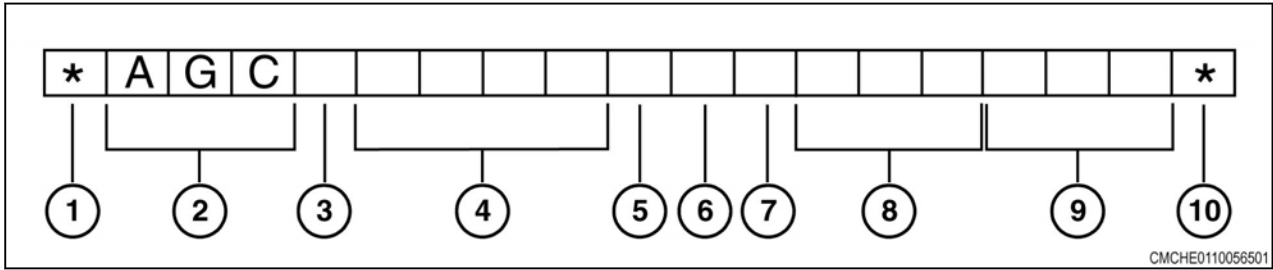

Fig. 2

2.2.2 Serial number description

Description of the serial number for model year 2010 and up.



CMCHE0110056501

Fig. 3

- | | |
|---|---|
| <ul style="list-style-type: none"> (1) Beginning symbol (2) World manufacturer code (3) Brand code (4) Model identifier (model number) (5) Check letter (0 or used if model identifier is five digits) | <ul style="list-style-type: none"> (6) Model year code (A=2010, B=2011, C=2012, and on) (7) Plant code (8) Family code (9) Unit number for the year (10) Ending symbol |
|---|---|

2.3 Air cart

The tanks on the air cart are made of stainless steel to prevent corrosion damage from granular fertilizer.

There are two basic models available that each have two size options:

- Two-bin model - 280 and 335 bushels
- Three-bin model - 380 and 525 bushels

2.4 Major components

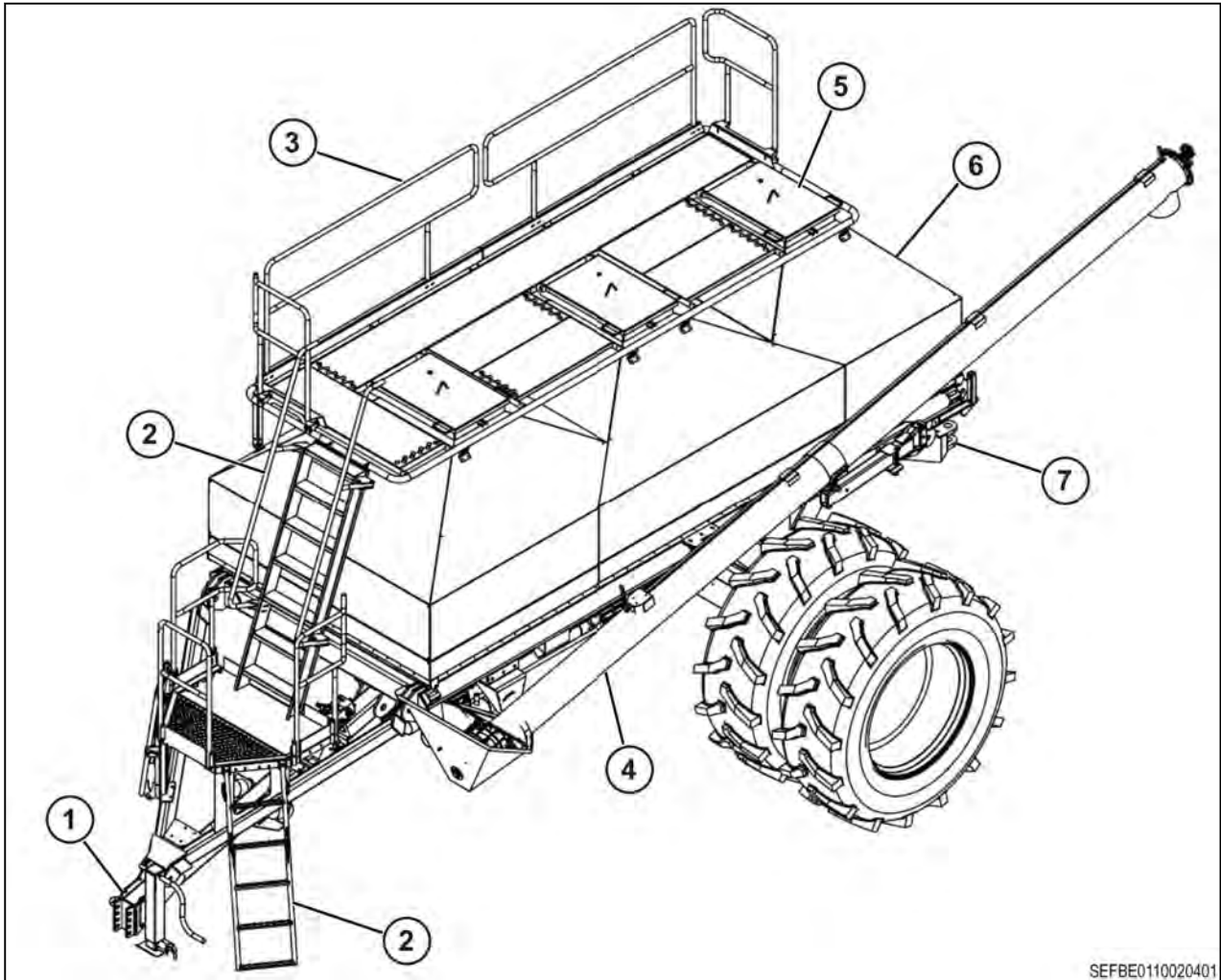

SEFBE0110020401

Fig. 4

The major components for the 3-bin model are shown. The major components for the 2-bin model are in similar locations.

- (1) Front hitch
- (2) Ladder
- (3) Railer
- (4) Auger
- (5) Product bin lid
- (6) Product bin
- (7) Rear hitch

Manual holder location

For the two-bin model, the manual holder (1) is located as shown.

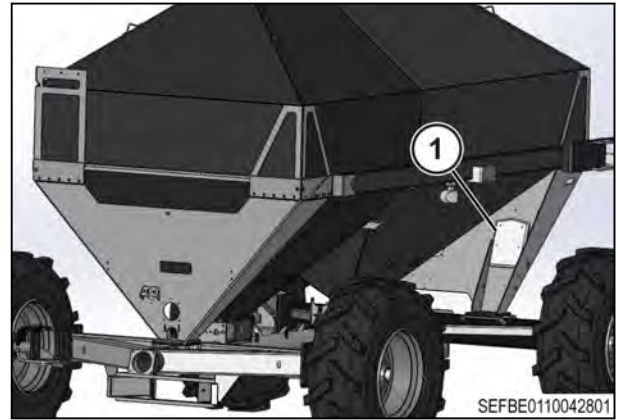

Fig. 5

For the three-bin model, the manual holder (1) is located as shown.

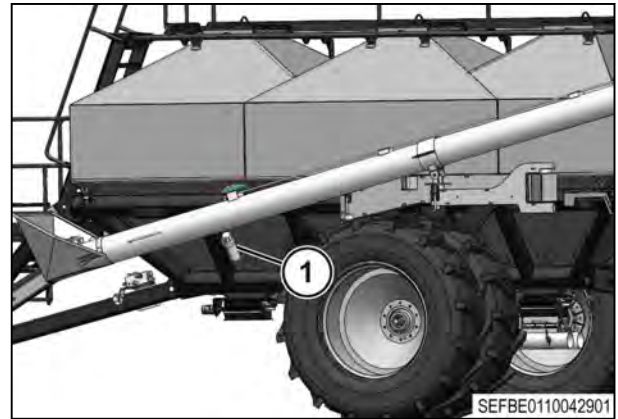

Fig. 6

2.5 Two-bin operator manual

2.5.1 Operator manual storage

The Operator Manual is located in the container (1) on the machine.



Fig. 7

2.6 Three-bin operator manual

2.6.1 Operator manual storage

The Operator Manual is located in the container (1) on the machine.



Fig. 8

3. Operation

3.1 Ladder and railings	51
3.1.1 Ladder and railings - two-bin model	51
3.1.2 Ladder and railings - three-bin model	51
3.2 Product bin lids	52
3.3 Auger	53
3.3.1 Using the auger to load products	53
3.3.2 Using the auger to unload products	55
3.3.3 Cleaning out the auger	55
3.4 Ground drive	56
3.5 Hydraulic systems	57
3.5.1 Air cart to drill hydraulic coupler	57
3.5.2 Air cart to tractor hydraulic couplers	57
3.6 Hydraulic drive	59
3.7 Blower	60
3.7.1 Blower speed	60
3.8 Selecting air stream	61
3.9 Meters	62
3.9.1 Product meter adjustment	62
3.9.2 Changing metering rolls - ground drive system	63
3.9.3 Changing metering rolls - hydraulic system	63
3.9.4 Meter roll options	64
3.9.5 Meter adjustments	64
3.9.5.1 Shims	64
3.9.5.2 Deflector block	64
3.9.5.3 Meter door and cleanout door latches	65
3.9.5.4 Meter door tray	65
3.10 Setting the application rate on a ground drive system	66
3.11 Hydraulic drive calibration and operation	68
3.11.1 Preparing to calibrate a meter	68
3.11.2 Priming the meter	69
3.11.3 Taking a product sample for calibration	70
3.11.4 Entering accumulated weight on the virtual terminal	70
3.11.5 Manually setting the motor cal value for a variable rate system	71
3.12 Rate charts	72
3.12.1 Fertilizer rate chart - 96 kg per cubic meter (60 lb per cubic foot)	72
3.12.2 Barley rate chart	74
3.12.3 Canola rate chart	76
3.12.4 Soybean rate chart	78
3.12.5 Wheat rate chart	80
3.13 Raven system	82
3.13.1 Raven system overview	82
3.13.2 Raven system hardware	82
3.13.2.1 Raven electronic control unit	82
3.13.2.2 Virtual terminal	82
3.13.2.3 Blower speed sensor	82
3.13.2.4 Bin level sensor	83
3.13.2.5 Meter box flow sensor	83
3.13.2.6 Meter shaft speed sensor (ground drive)	83
3.13.2.7 Meter shaft speed sensor (hydraulic drive)	84

3.13.2.8 Ground speed sensor	84
3.14 Cart control system	85
3.14.1 Virtual terminal - cart control system	85
3.14.2 Alarm and indicator icons	85
3.14.3 Confirmation screen	86
3.14.4 Main (home) screen	87
3.14.5 Product bin alarms	89
3.15 System set up	90
3.15.1 System settings screen	90
3.15.2 Work switch operation	91
3.15.3 Selecting the external work switch operation mode	92
3.15.4 Manual work switch operation	92
3.15.5 Setting the automatic work switch operation	92
3.15.6 Dry product/bin settings	92
3.16 Advanced setup	94
3.17 Sensor types	96

3.1 Ladder and railings

3.1.1 Ladder and railings - two-bin model

The air cart is equipped with a ladder and railings for access to the top of the tanks. Always make sure the railings are fastened in the raised position when operating the air system. The railings can be lowered for storage or servicing, if required.

To lower the railings:

1. Use a ladder that is of the correct height, when put on the ground to reach the top of the machine, to remove the top bolt from each of the legs on the railing sections.
2. Rotate the railing section down so that the railing sections are next to the air system.
3. Install the bolts in the holes for storage.



WARNING:

Falling hazard. Personal injury or death can occur. Do not stand on the top of the machine when raising or lowering the railings. Read and follow the instructions in the operator's manual for the movement of the railings.



Fig. 1

3.1.2 Ladder and railings - three-bin model

The air cart is equipped with a ladder and railings for access to the top of the tanks. Always make sure the railings are fastened in the raised position when operating the air cart. The railings can be lowered for storage or servicing, if required.

To lower the railings:

1. Use a ladder that is of the correct height, when put on the ground to reach the top of the machine, to remove the spring pins.
2. Fold down the side railings over the top of the tank.
3. Fold down the front and rear hand rails over the side rails.
4. Install the spring pins for storage.



WARNING:

Falling hazard. Personal injury or death can occur. Do not stand on the top of the machine when raising or lowering the railings. Read and follow the instructions in the operator's manual for the movement of the railings.



Fig. 2

3.2 Product bin lids

The product bin lids on the air cart compartments must be correctly closed and sealed for the meters to supply product correctly.

Periodically check the product bin lids for correct adjustment and inspect the seal for damage.

To determine whether the product bin lid is adjusted correctly, watch the product bin lid as the latch is opened. The product bin lid must tilt a little toward the latch end. A pull on the latch handle is required to over-center the latch.

To adjust the hinge end of the product bin lid, loosen or tighten the jam nuts (1) on the hold down bar.

To adjust the latch, loosen or tighten the nuts (2) on the toggle U-bolt.

In the off season, release the latch to relieve pressure on the gasket.

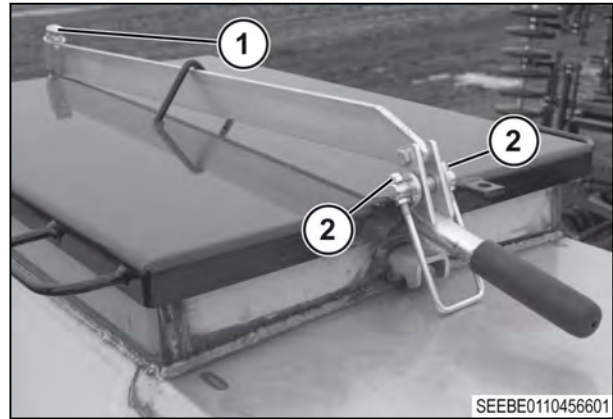

Fig. 3

3.3 Auger

The air cart is equipped with an auger (1) for loading and unloading the product bins. The auger is mounted in a swing arm. A flexible discharge hose is mounted on one end. This hose can be moved from one compartment to another without moving the hopper. The swing arm also enables the auger to be turned around to unload and clean out the compartments.

The hydraulic drive for the auger is supplied with oil from the blower hydraulics. A diverter valve in rear of the machine supplies oil to the auger. The diverter valve can be switched with the blower running. The diverter valve at the rear of the machine selects either the fan or auxiliary (auger and/or winch) function. Push the knob in to run the blower. Pull the knob out to run the auger or winch.

The auger has a three position variable speed valve to run the auger forward, rearward, or to stop.

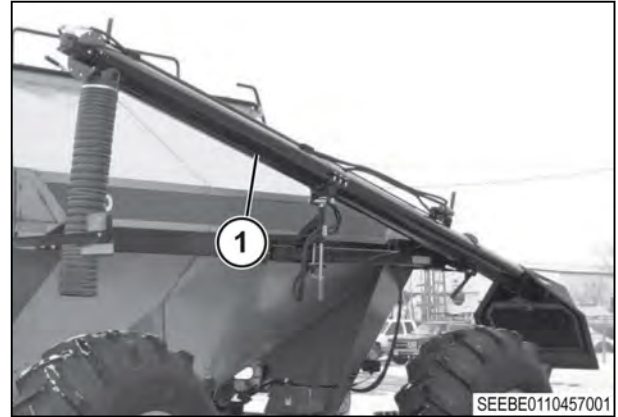

Fig. 4

3.3.1 Using the auger to load products

Procedure

1. Park the machine on a solid, level surface.
2. Apply the park brake.
3. For the two-bin models, put the auger on the ground to correctly load the material:
 - a) Drop the front bracket lock pin (1) just far enough to release the small pivot arm (2). Do not remove the pins for the long arm.
 - b) On the inner arm and the outer arm, pull down the spring loaded pin into the detent position.
 - c) Remove the auger from the rear clamp assembly.
4. For the three-bin models only, put the auger in the operating position:

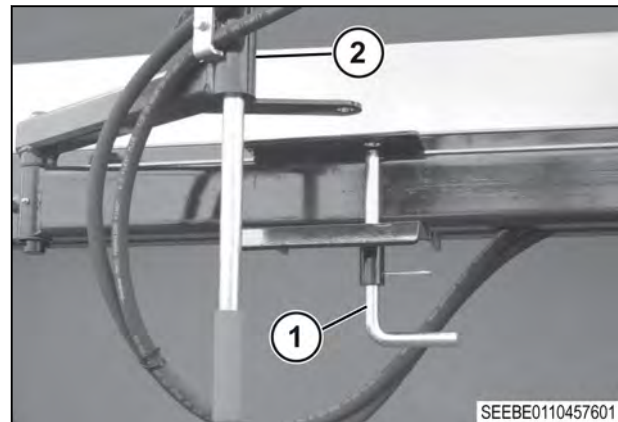

Fig. 5

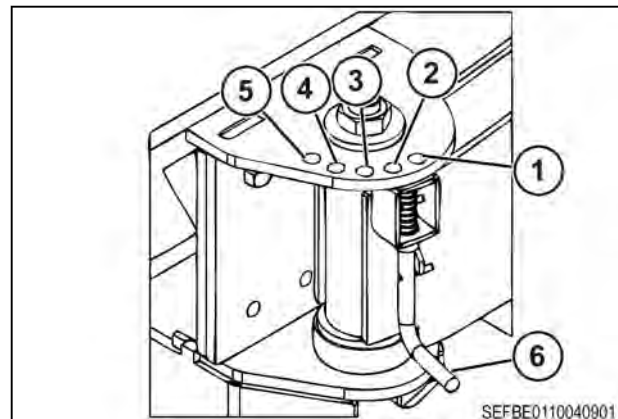

Fig. 6

Lock Pin Location Reference				
Item	Location	Bin 1 (front bin)	Bin 2 (middle bin)	Bin 3 (rear bin)
(1)	Position 1	Stowed	Stowed	Stowed
(2)	Position 2	Not Used	Not Used	Load
(3)	Position 3	Unload	Load	Unload
(4)	Position 4	Load	Load	Load
(5)	Position 5	Not Used	Not Used	Not Used

- a) Drop the lock pin (6) in the neutral position.
 - b) On the inner arm and the outer arm, pull down the spring loaded pin into the detent position.
 - c) Remove the auger from the clamp.
 - d) Pull the inner arm into position, by swinging the hopper away from the air cart.
 - e) Release the detent pin on the inner arm and lock into place.
 - f) Pull down the outer arm pin so the auger is free to move from the inner arm.
5. Put the hopper on the ground:
 - For two-bin models, put the hopper in a position vertical to the center line of the tanks with the discharge end of the auger between the compartment covers. From this position the discharge end of the auger can move between compartments without moving the hopper.
 - For three-bin models, put the hopper on the ground in a position perpendicular to the center tank lid. From this position the discharge end of the auger can be moved between compartments without moving the hopper.
 6. Put the hopper over the lid of the desired tank to be filled.
 7. Push the divert valve knob in to run the blower. Pull the diverter valve out to run the auger or winch.
 8. On three-bin models, put the spring loaded pin into the detent position before moving to a different compartment or damage can occur.

3.3.2 Using the auger to unload products

Procedure

1. Swing the inner arm far enough away from the machine to let the hopper fit in front of the wheels.
See the information for inner arm position.

2. Put the hopper (1) under the meter for the desired compartment.

For rear tank on three-bin models, the outer arm will have to swing more than 180 degrees to reach the meter.

3. Close the metering slide (2).
4. Remove the product meter door (3).
5. Open the metering slide to control flow from the compartment.

Removing the pointer lets the gate open without changing the rate setting.

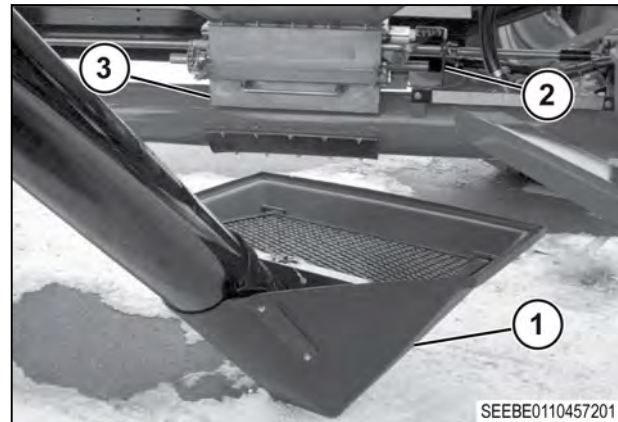

Fig. 7

3.3.3 Cleaning out the auger

Procedure

1. Park the machine on a solid, level surface.
2. Apply the park brake, stop the engine, and take the key with you.
3. If desired, put a catch pan under the auger.
4. Put the hopper (1) upside down to empty.
5. If desired, put a catch pan under the auger.
6. Run the auger rearward until the auger tube is empty.

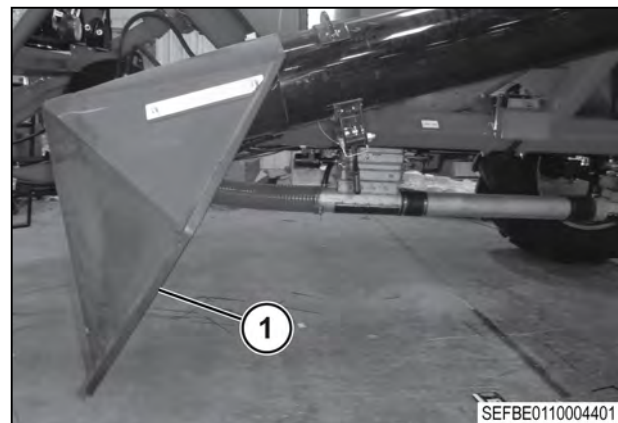

Fig. 8

3.4 Ground drive

On air carts equipped with ground drive a magnetic clutch disengages the drive. The magnetic clutch uses electrical power to hold the engaged position. The clutch is turned on and off by the control system either automatically when the drill is raised and lowered, or manually by pressing a manual master work switch on the virtual terminal in the tractor cab. The clutch requires no service.

When roading long distances, remove the drive chain at the drive wheel. This will extend the life of the chain and the sprocket.

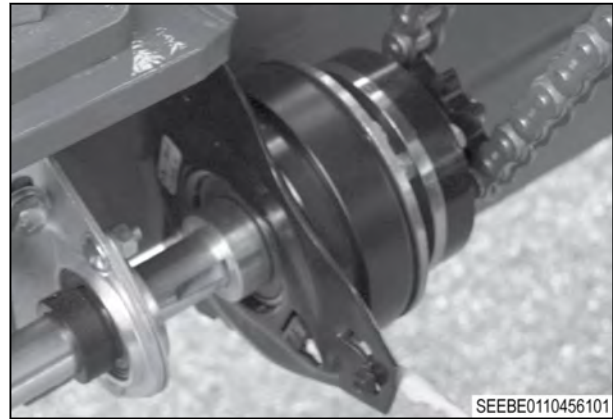

Fig. 9

3.5 Hydraulic systems

The hydraulic system on the air carts includes:

- Blower control circuit
- Auger control circuit
- Hydraulic meter drive control circuit

A group of control valves enables all three circuits to be operated by one hydraulic remote on the tractor. This system was designed to function under a maximum hydraulic pressure of 19 995 kPa (2900 psi).

Fan with hydraulic drive	10cc fan motor with 5 gal meter priority	
Fan speed	Flow	Pressure
3000 rpm	49.2 l/min (13 gal/min)	8174 to 11 721 kPa (1200 to 1700 psi)
4000 rpm	60.6 l/min (16 gal/min)	11 032 to 4 479 kPa (1600 to 2100 psi)
5000 rpm	70 l/min (18.5 gal/min)	13 790 to 17 237 kPa (2000 to 2500 psi)
6000 rpm	79.5 l/min (21 gal/min)	16 547 to 19 995 kPa (2400 to 2900 psi)

Fan only	10cc fan motor	
Fan speed	Flow	Pressure
3000 rpm	30.3 l/min (8 gal/min)	6895 to 10 342 kPa (1000 to 1500 psi)
4000 rpm	39.7 l/min (10.5 gal/min)	9653 to 13 100 kPa (1400 to 1900 psi)
5000 rpm	51 l/min (13.5 gal/min)	12 411 to 15 858 kPa (1800 to 2300 psi)
6000 rpm	60.6 l/min (16 gal/min)	15 168 to 18 616 kPa (2200 to 2700 psi)

3.5.1 Air cart to drill hydraulic coupler

The couplers connecting the air cart to the drill/implement are (3/4 inch) #12 ISO 7241 Series B, high-flow couplers. Using the high-flow couplers reduces the pressure drop across the coupler and enables the operator to easily disconnect the air cart from the drill/implement. Make sure the pressure line on the tank is connected to the pressure line on the drill.

The blower motor case drain line has a (5/8 inch) #10 ISO 7241 Series B coupler. The smaller size helps to tell the difference between this coupler and other larger couplers.

IMPORTANT:

Be sure that the case drain line on the blower motor is not connected to pressure. Damage to the shaft seal or motor will result.

3.5.2 Air cart to tractor hydraulic couplers

The couplers connecting the blower pressure and the return lines from the air cart to the tractor are #8 (1/2 inch) ISO 5675 (Pioneer) tip coupler to a #10 (5/8 inch) female ORB.

A #8 ISO 16028 (flat-face) coupler tip to a #6 (3/8 inch) female ORB on the air cart connects the case drain line to the tractor. The case drain line must be connected or the blower motor will be damaged. If a case drain return port is not available on your tractor, contact your dealer.

A (3/4 inch) #12 ISO 7241-1 Series A low-pressure return tip is included with all implements. The low-pressure return tip is also available through Service Parts.

If your tractor has a low-pressure port available, the low-pressure return tip can be used on the 3/4 inch blower return line. Using the low-pressure return tip can remove the pressure drop caused by the 1/2 inch Pioneer tip and the hydraulic valve of the tractor on the return side. The low-pressure return tip can also be used on the case drain line, if the 3/8 inch flat face port is not available.

Do not install a tee fitting connecting the blower return line and the blower case drain lines together. The blower case line must always be connected to a direct return to the hydraulic reservoir or blower motor failure will result.

The hydraulic line with the label pressure must be used to operate the blower. A check valve is installed in the blower circuit to protect the motor from the too much pressure in the return line and prevents cavitation during shutdown.

NOTE:

The 3/4 inch low pressure return tip is not compatible with the 3/4 inch high flow fittings used at the front of the cart. The connectors look similar, but the connectors are not compatible.

3.6 Hydraulic drive

Air systems equipped with the hydraulic drive option use electric-over-hydraulic (EOH) technology to control the meter speed independently of ground speed. This gives the operator a faster calibration procedure and on-the-go rate changing capability as well as the option to apply product to a prescription map using GPS.

The hydraulic control valve uses 18.9 l/min (5 gal/min) of hydraulic fluid flow from the fan circuit to power the variable rate drive motors. An electro-proportional flow-control valve controls the speed of each motor, letting the meters turn at speeds completely independent of each other.

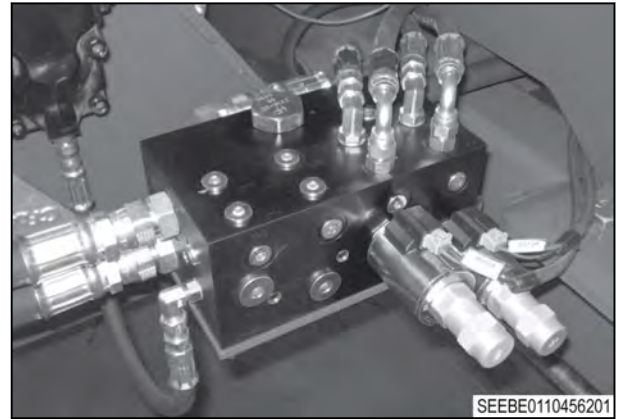

Fig. 10

3.7 Blower

The blower system for the air cart generates air pressure/flow to carry the seed or other input products through the system to the implement. A hydraulic motor drives the blower system. Two 3/4 inch hydraulic lines supply oil to the blower.

The only part on the blower that can be serviced is the shaft seal. The shaft seal can be replaced if the motor leaks at the shaft. Do not disassemble the motor to replace the shaft seal. The shaft seal is fastened by a snap ring and can be removed with a seal pick.

IMPORTANT:

Be sure that the case drain line on the blower motor is not connected to pressure. Damage to the shaft seal or motor will result.

IMPORTANT:

Do not under any circumstances disassemble the motor. The motor is very difficult to correctly assemble and motor destruction will result. If a motor failure occurs, get a replacement motor from the dealer.



Fig. 11

3.7.1 Blower speed

Operate the blower at as slow a speed as possible to prevent damage to seed. If operated too slowly, line blockage will occur. Typical blower speeds are between 3000 and 6000 rpm. The drill width, product, rate, humidity, and other factors can change blower speed.

If a run blockage monitor is not used, make sure all runs are operating after changing blower speeds. To check the runs:

1. Turn the meter(s) with the blower running
2. Make sure there is product at each ground opener

If high rates are being applied with this implement and the implement is equipped with two fans, use the fan only circuit with the low pressure return fitting. This will help decrease the back pressure in the circuit and give the maximum output.

The number of outlets on the implement will directly change the blower rpm. The more outlets in use, the higher the pressure required to keep blower rpm. See your dealer for hydraulic adjustments to your tractor, if necessary.

A diverter valve in front of the cart selects the fan or auxiliary function. Push the knob in to run the blower. Pull the knob out to run the auger or winch.

One method to determine blower RPM is to remove a final run from the seed boot or shoe. Hold the hose about 1.5 meter (5 ft) off of the ground pointing straight up. Turn product out of the meter with the blower running. The product coming from the hose must blow out of the hose approximately 203 mm (8 inches) into the air. Adjust blower RPM as required.

3.8 Selecting air stream

In dual chute equipped systems; one can switch air streams for any desired products.

Procedure

1. Remove the wing nuts (1) from the baffle slide and the plug.
2. Remove the baffle slide.
3. Move the baffle slide into the desired air stream.
4. Install the plug and the wing nuts.
Do not use wrench to tighten the wing nuts. Over tightening will cause failure of the stud.
5. Move the pressurization tube to the desired air stream.

If changing air streams frequently, apply a small amounts of an anti-seize compound to the studs. This will keep the studs from seizing and becoming broken.

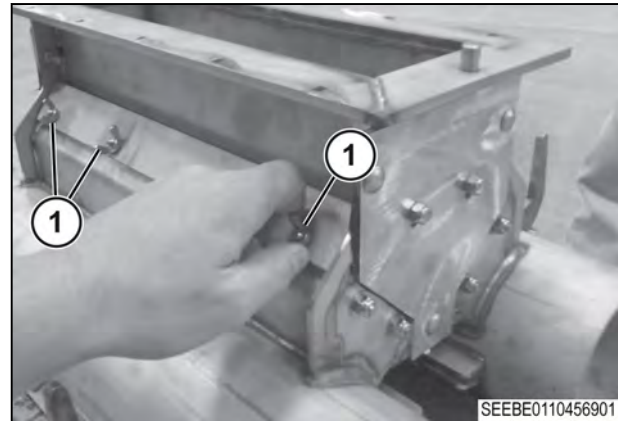

Fig. 12

3.9 Meters

3.9.1 Product meter adjustment

The product meters send the seed or fertilizer from the product bins to the air stream through a fluted roller. The amount of the roller being used determines the rate at which products are applied.

There are two moveable components in the meter that determine the rate setting:

- Flow plate
- Meter shut off slide

The flow plate (1) controls how much of the meter roller will be used. The meter shut off slide (2) opens to the stop on the pointer for any rate setting. When making large rate reductions, close the slide and empty the meter to let the flow plate move to the lower setting. After the flow plate is moved, open the meter shut off slide until contact is made with the stop on the pointer.

The primary setting is a flow plate adjusted by a rod connected to a pointer. When a rate setting is selected, the pointer is put at the number shown on the rate decal. A lock bolt on the pointer rod holds the setting.

The second part of the adjustment is the meter shut off slide. For any rate setting the correct location for meter shut off slide is against the stop on the pointer. This opens the bottom of the tank compartment the correct amount for the rate setting. A 12.5 mm (0.5 inch) drive ratchet is supplied in the toolbox for adjusting the meter shut off slide.

Any time a new rate is set, calibrate the meter. A scale and a catch bag are supplied in the tool box for use during the calibration procedure.

Once a rate setting is determined from the rate charts and the meter is set to the correct setting, do the calibration procedures.

When using both tanks for one product, determine the rate for each meter by splitting the desired rate by the ratio of the tanks (60/40). This will result in both tanks being empty at the same time.

Examples:

To seed 135 kg per hectare of wheat using both meters, split the desired rate to the ratio of the size of the tanks. For a 60/40 split, set one meter to 81 kg (135 kg x .60) and the other meter to 54 kg (135 kg x .40)

To seed 120 lbs per acre of wheat using both meters, split the desired rate to the ratio of the size of the tanks. For a 60/40 split, set one meter

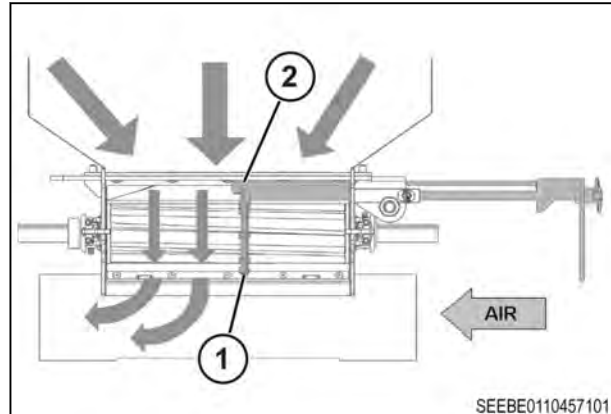

Fig. 13

to 72 lbs (120 lbs x .60) and the other meter to 48 lbs (120 lbs x .40).

When decreasing the meter setting, close the shutoff slide and turn the meter, if necessary. This procedure will empty the meter and let the plate move to a smaller setting.

3.9.2 Changing metering rolls - ground drive system

Procedure

1. Close the meter gate or make sure the bin is empty.
2. Remove the meter door.
3. Remove the chain (1) from the meter drive sprocket.
Do not remove the sprocket.
4. On the sprocket end of the meter drive only, remove the two nuts (2) that hold the bearing to the meter shaft.
5. Pull the shaft (3) out of the meter drive while holding on the the metering roll (4).
6. Remove the metering roll.
7. Install the desired metering roll.
8. Install the shaft into the meter drive through the metering roll.
9. Install the two nuts that hold the bearing to the meter shaft.
10. Install the chain to the meter drive sprocket.
11. Install the meter door.

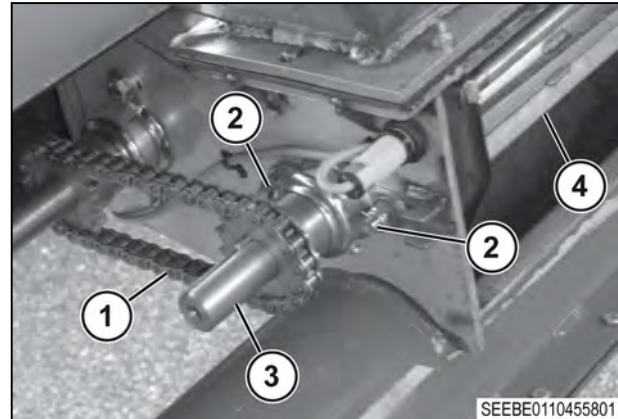

Fig. 14

3.9.3 Changing metering rolls - hydraulic system

Procedure

1. Close the meter gate or make sure the bin is empty.
2. Remove the meter door.
3. Remove the two 1/2 inch bolts (1) fastening the hydraulic motor to the motor mount.
4. On the motor end of the meter drive only, remove the two nuts (2) that hold the bearing to the meter shaft.
5. Pull the shaft (3) connected to the hydraulic motor out of the meter drive while holding on the the metering roll (4).
6. Remove the metering roll.
7. Install the desired metering roll.
8. Install the shaft connected to the hydraulic motor into the meter drive through the metering roll.
9. Install the two nuts that hold the bearing to the meter shaft.
10. Install the two 1/2 inch bolts fastening the hydraulic motor to the motor mount.

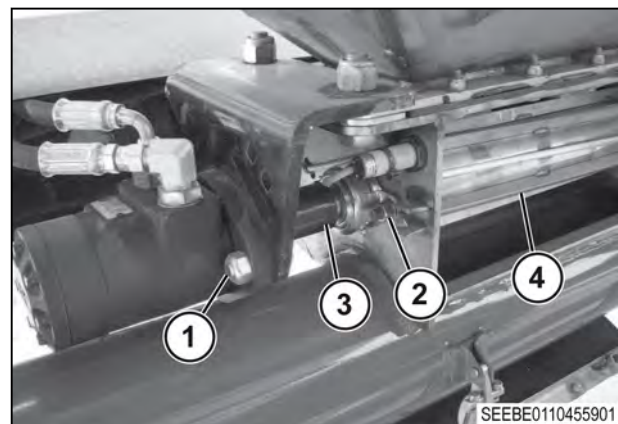

Fig. 15

11. Install the meter door.

3.9.4 Meter roll options

Four meter roll options are available:

- The high capacity roll has eight 12.7 mm (1/2 in) deep bars and is used for most applications.
- The medium capacity roll has 12 6.4 mm (1/4 in) deep bars and is used on smaller machines or for lower seeding or fertilizer rates.
- The low volume roll has a pattern of short, shallow depressions to gradually longer, deeper depressions for very low seeding rate.
- The fine product meter roll has a continuous pattern of shallow depressions for very low seeding rates with high accuracy.

3.9.5 Meter adjustments

The following adjustments are done at the factory and done only be done by a trained service technician.

3.9.5.1 Shims

The meter roll has a 0.762 mm (0.030 in) gap between the roll and the meter housing for correct operation. If the gap is too large product can leak around the meter roll into the air stream. If the gap is too tight the meter roll will not move on the housing and cause problems with the meter drive system.

A 0.762 mm (0.030 in) thick shim can be installed between the meter roll and the meter housing to reduce this gap. The meter shaft must be removed to install this shim. See the information for changing meter rolls.

Make sure the meter roll turns freely after installing or removing any shims. If the meter roll does not turn freely, do not operate the air system until enough shims have been removed to let the meter roll turn freely.



Fig. 16

3.9.5.2 Deflector block

The deflector block (1) at the rear of the meter prevents seed from flowing around the back side of the meter roll. If necessary, vertically adjust the deflector block to increase or decrease the clearance to the meter roll.

To adjust the deflector block:

1. Loosen the two nuts (2) on the back side of the meter housing.
2. Move the deflector block to the desired position.
3. Tighten the two nuts on the back side of the meter housing.

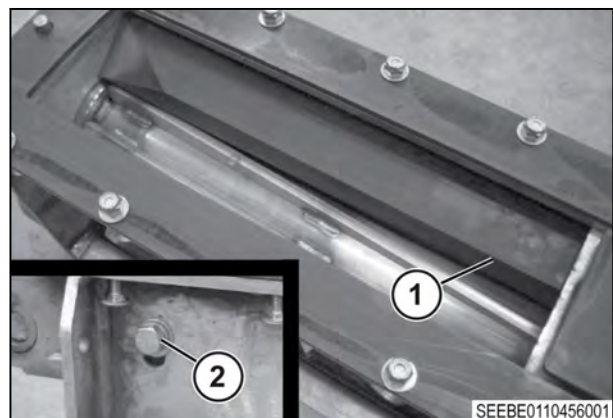

Fig. 17

3.9.5.3 Meter door and cleanout door latches

The tension on the cleanout door latches (1) and the meter door latches (2) can be adjusted to increase or decrease the preload on the cleanout door and the meter door. If the preload is too small, the doors will not seal correctly. If the tension is too tight, the latches will be difficult to close.

The tension can be adjusted by opening each latch and turning the two stop-nuts evenly in or out.

Make sure the door preload is enough before putting the unit back into service.

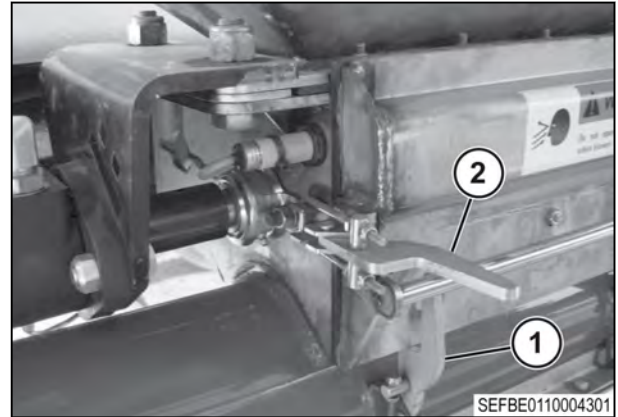

Fig. 18

3.9.5.4 Meter door tray

The tray (1) on the meter door can be adjusted vertically in order to increase or decrease the tension between the rubber seal on the tray and the meter roll.

To adjust the meter door tray:

1. Loosen the two nuts (2) holding the tray to the meter door.
2. Move the tray to the desired position.
3. Tighten the nuts to lock the tray into position.

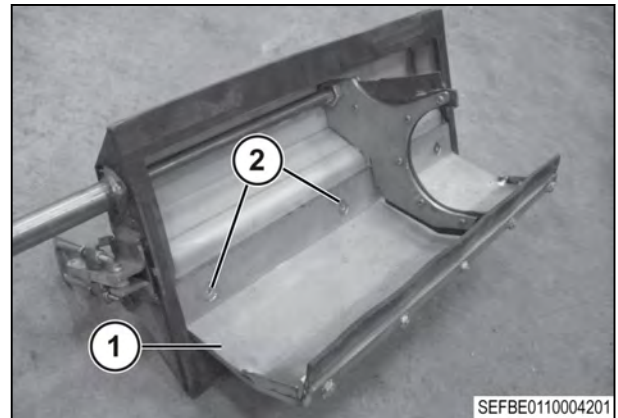

Fig. 19

3.10 Setting the application rate on a ground drive system

Before starting the procedure

See the information for preparing to calibrate a meter. See the information for priming the meter. See the information for taking a sample for calibration. Close the slide gates for any meter not being calibrated.

The ground drive (GD) system changes meter speed as necessary to keep a constant application rate.

Procedure

1. Connect the machine hitch to a tractor.
2. Put the tractor hydraulic remote in the neutral position.
3. Connect the machine hydraulic lines to the tractor.
4. Connect the machine terminal harness to the terminal harness.
5. Start the tractor.
6. Put the transmission in park and apply the park brake.
7. Turn on the terminal.
Make sure the terminal and the machine electronic control unit (ECU) connect.
8. Determine the desired application rate from the ground drive part of the rate charts.
Look up the rate setting for each tank separately. Use the correct rate chart.
9. Loosen the thumb screw on the pointer shaft so the pointer shaft can move.
10. Set the pointer to the desired application rate.
11. Tighten the thumb screw to hold the setting.
12. Open the slide gate with the supplied ratchet wrench until the slide gate contacts the stop on the pointer.
13. Hang the empty calibration bag on the weighing scale included with the machine.
14. Zero out the weight of the empty calibration bag.
15. Release the toggle clamps and open the cleanout door under the air tube.
16. Turn the crank at the front of the air system one complete revolution to prime the meter.
17. Install the calibration bag on the meter tube with the cleanout door inside the bag.
The bag must be under the openings in the bottom of the air tube.
18. To calibrate a seeding rate for most seeds, determine the number of crank turns to cover 0.04 ha (0.1 acre).
19. To calibrate a seeding rate for seeds with a small weight per area, use more crank turns than required for 0.04 ha or (0.1 acre).
Canola seeds and sunflower seeds require a larger number of crank turns for correct calibration.
20. To calibrate a seeding rate for seeds with a very small weight of seed per area, use the crank turns for 0.4 ha (1 acre).
21. Manually crank the meter the required number of turns.

Machine width, turns of the crank, teeth, and tire sizes		
Machine Width in m or (ft)	Turns of the crank per ha (acre) with a 10 tooth gearbox sprocket and 23.1R26 tires	Turns of the crank per ha (acre) with a 15 tooth gearbox sprocket and 23.1R26 tires or with a 17 tooth gearbox sprocket and 18.4R26 tires.
9.1 m (30 ft)	467 turns per ha (189 turns per acre)	311 turns per ha (126 turns per acre)
9.8 m (32 ft)	441 turns per ha (179 turns per acre)	294 turns per ha (119 turns per acre)
10.4 m (34 ft)	415 turns per ha (168 turns per acre)	277 turns per ha (112 turns per acre)
11.0 m (36 ft)	393 turns per ha (159 turns per acre)	262 turns per ha (106 turns per acre)

Machine width, turns of the crank, teeth, and tire sizes		
Machine Width in m or (ft)	Turns of the crank per ha (acre) with a 10 tooth gearbox sprocket and 23.1R26 tires	Turns of the crank per ha (acre) with a 15 tooth gearbox sprocket and 23.1R26 tires or with a 17 tooth gearbox sprocket and 18.4R26 tires.
11.6 m (38 ft)	371 turns per ha (150 turns per acre)	247 turns per ha (100 turns per acre)
12.2 m (40 ft)	352 turns per ha (143 turns per acre)	235 turns per ha (95 turns per acre)
12.8 m (42 ft)	334 turns per ha (135 turns per acre)	222 turns per ha (90 turns per acre)
13.4 m (44 ft)	319 turns per ha (129 turns per acre)	213 turns per ha (86 turns per acre)
13.7 m (45 ft)	315 turns per ha (128 turns per acre)	210 turns per ha (85 turns per acre)
14.0 m (46 ft)	308 turns per ha (125 turns per acre)	205 turns per ha (83 turns per acre)
14.6 m (48 ft)	293 turns per ha (119 turns per acre)	195 turns per ha (79 turns per acre)
15.2 m (50 ft)	282 turns per ha (114 turns per acre)	188 turns per ha (76 turns per acre)
15.8 m (52 ft)	271 turns per ha (110 turns per acre)	180 turns per ha (73 turns per acre)
16.5 m (54 ft)	259 turns per ha (105 turns per acre)	173 turns per ha (70 turns per acre)
17.1 m (56 ft)	252 turns per ha (102 turns per acre)	168 turns per ha (68 turns per acre)
17.7 m (58 ft)	245 turns per ha (99 turns per acre)	163 turns per ha (66 turns per acre)
18.3 m (60 ft)	234 turns per ha (95 turns per acre)	63 turns per ha (63 turns per acre)

22. Remove the calibration bag.
23. Weigh the calibration bag.
24. For most seeds, multiply the sample weight times ten to get the rate per 0.4 ha (1.0 acre).
25. For seeds with a small weight per area multiply the sample weight by the inverse of the sample percent.
 Examples: For a 50 percent sample size, $(1.0/0.5 = 2)$ multiply by two; for a 40 percent sample size, $(1.0/0.4 = 2.5)$ multiply by 2.5.
26. For seeds with a very small weight per area, use the sample weight.
27. Repeat the procedure if necessary, adjusting the meter to a higher or lower setting to get the desired rate.

After finishing the procedure

Recalibrate rates after seeding with a partial tank of seeds.

3.11 Hydraulic drive calibration and operation

3.11.1 Preparing to calibrate a meter

Calibrate meter when:

- Changing the gate setting
- Changing the product
- Changing the meter roll

Calibrate each meter even if all gates have the same setting.

Procedure

1. Connect the machine hitch to a tractor.
2. Put the tractor hydraulic remote in the neutral position.
3. Connect the machine hydraulic lines to the tractor.
4. Connect the machine terminal harness to the terminal harness.
5. Start the tractor.
6. Put the transmission in park and apply the park brake.
7. Turn on the terminal.
Make sure the terminal and the machine electronic control unit (ECU) connect.
8. Check the meter gate for correct connection to the meter roll.
If necessary, make corrections.

9. Check the bin for product.
The bin must be a minimum of 25 percent full.
10. Adjust the meter gate (1) for the correct application rate.
The measuring rule (2) shows inches and parts of an inch.

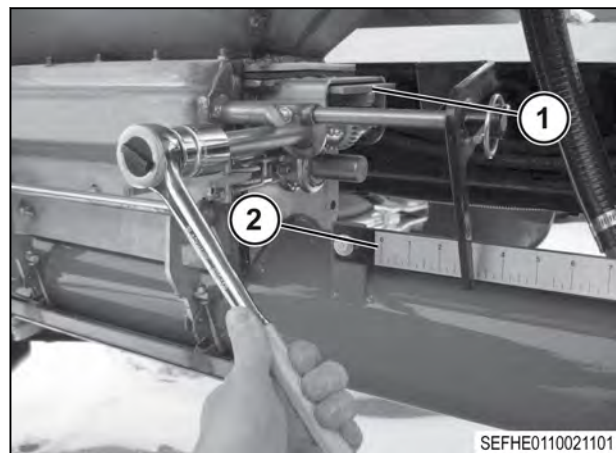

Fig. 20

11. Use the following table to set the meter gate.

Meter gate setting guide for hydraulic drives with high capacity meter rolls				
Rate in kg/ha (lbs/acre)	9 m (30 ft)	12 m (40 ft)	15 m (50 ft)	18 m (60 ft)
56 kg/ha (50 lb/acre)	76 mm (3 in) .5 lbs/rev	102 mm (4 in) .66 lbs/rev	127 mm (5 in) .83 lbs/rev	152 mm (6 in) 1.0 lbs/rev
112 kg/ha (100 lb/acre)	102 mm (4 in) .33 lbs/rev	152 mm (6 in) 1.0 lbs/rev	203 mm (8 in) 1.33 lbs/rev	254 mm (10 in) 1.66 lbs/rev
168 kg/ha (150 lb/acre)	152 mm (6 in) 1.0 lbs/rev	203 mm (8 in) 1.33 lbs/rev	254 mm (10 in) 1.66 lbs/rev	maximum opening 2.0 lbs/rev
224 kg/ha (200 lb/acre)	203 mm (8 in) 1.33 lbs/rev	254 mm (10 in) 1.66 lbs/rev	maximum opening 2.0 lbs/rev	maximum opening 2.0 lbs/rev

12. Operate the auger selector valve (1) to send hydraulic oil to the fan/meter circuit.
13. Close the blower ball-valve.
14. Engage the tractor hydraulic remote controlling the blower circuit.
Make sure the blower does not rotate. If the blower rotates, close the blower ball-valve.
15. Open the cleanout door below the meter to be calibrated.

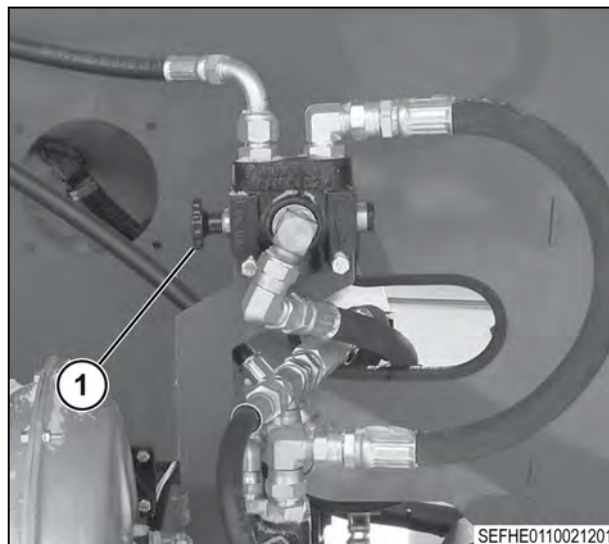

Fig. 21

Priming the Meter

The electronic control unit (ECU) has a touch pad (1) that will be used for calibration.

Before starting the procedure:

Enter the Rate Sensor Setup Screen (1) found in the System settings menu.

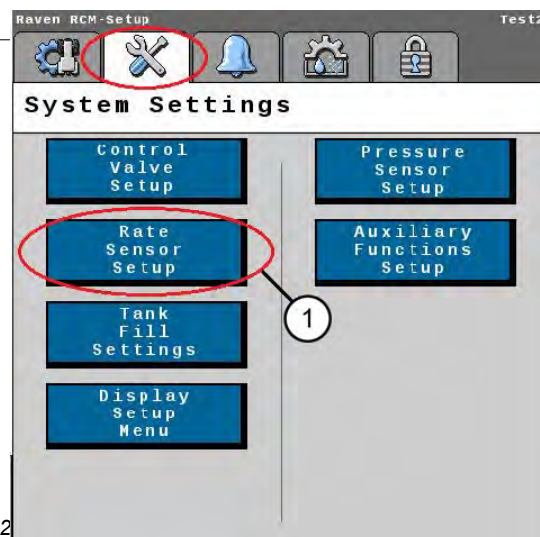

Fig. 22

From the table on previous page enter a Calibration Rate based metering wheel, width of machine, and rate desired for each (PR) Product (1).

This calibration value is a starting point at which you will need to start the calibration procedure.

If the product density is known, enter it for the desired product.

Do not Change the Product Density After Calibrating - The calibration number will change

Be sure that the Master Apply switch is on and green.

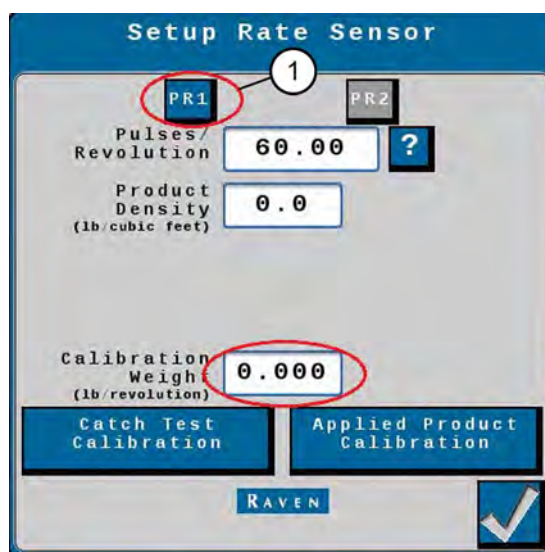

Fig. 23

Setting Machine Width:

Select Settings and select the Applicator Set up tab.

Verify that your machine width (1) is populated correctly.

If the width is correct move onto the calibration procedure, if not follow the next steps:

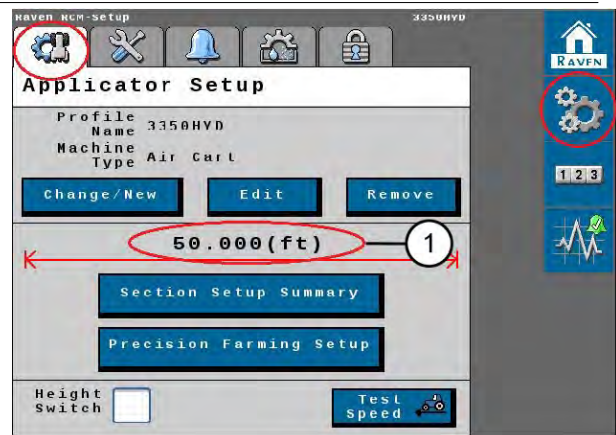

Fig. 24

1. Select Edit

- a. The ECU will prompt you asking if want to Remove/Edit (1) a profile from the list, Select the Check Mark

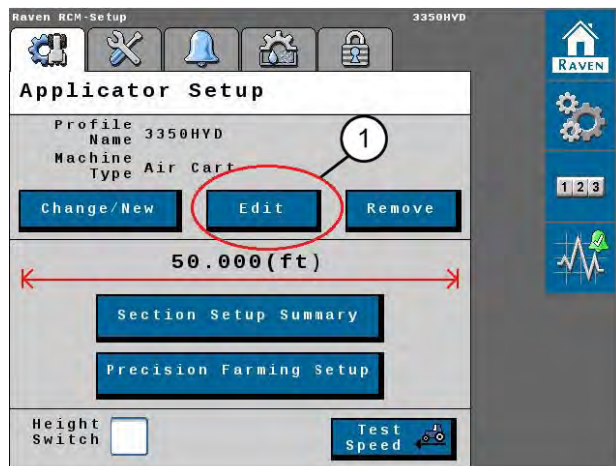

Fig. 25

2. Select Profile name;

- a. Typically this is the Model and Drive type of the Air cart: ie: 3350HYD

3. Change the Application Width (1) of the machine.

4. Page Through the next screens until you reach the Set up Summary;

- a. Verify all settings are correct and select next.

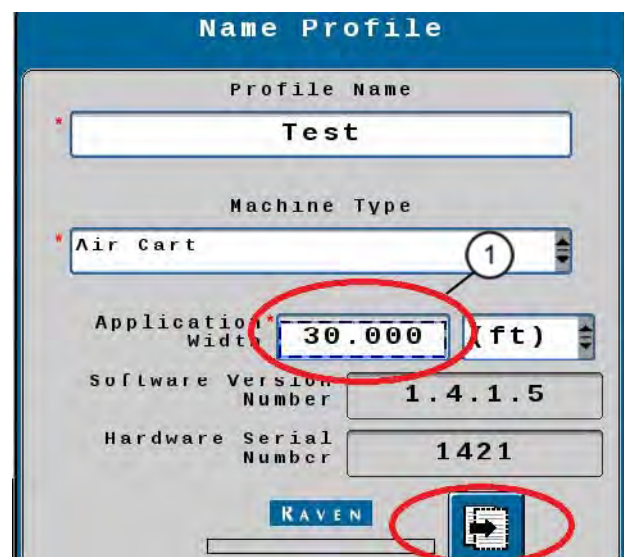

Fig. 27

3.11.3 Taking a product sample for calibration from the Auxillary Display

Before starting the calibration procedure:

The meter roll must be primed with product before calibrating the meter.

Procedure:

1. Hang Calibration Bag (1) under meter being calibrated (Fig. 24)

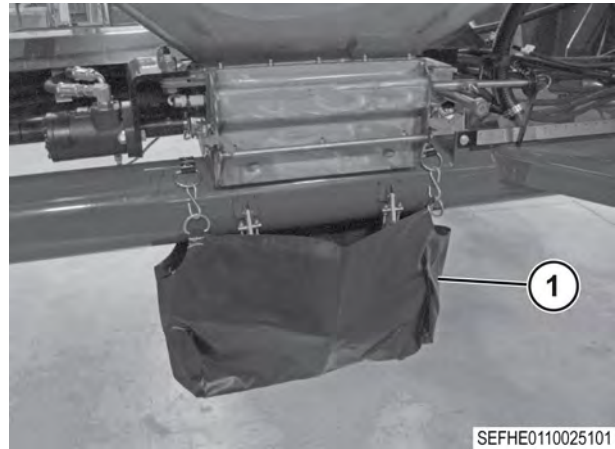

Fig. 24

2. Enter the Rate Calibration Menu;
 - a. Use arrow pad to navigate.
 - b. Press "ok" to enter menu.



Fig. 25

3. Select the product using the left and right arrow keys (1).
 - a. Note the Current Calibration should match what was entered into the terminal in the cab.
4. Select CALIBRATE using the rightmost button.

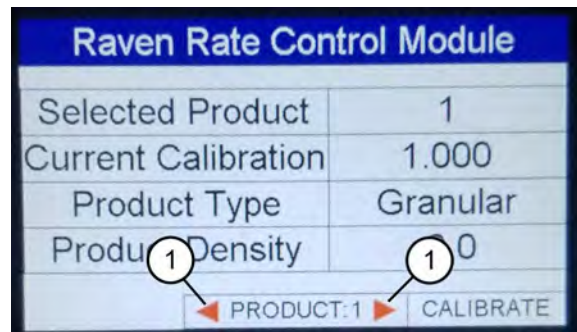

Fig. 26

5. A Warning screen will appear;
 - a. PLEASE READ THIS WARNING
 - b. Press "ok".

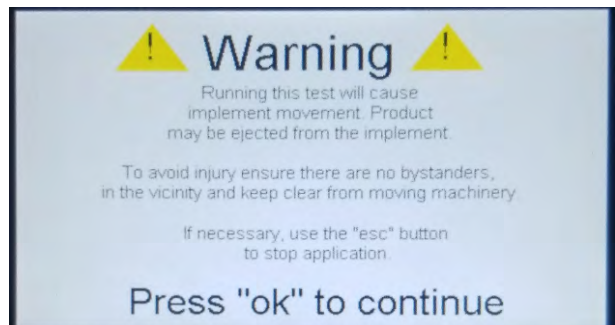
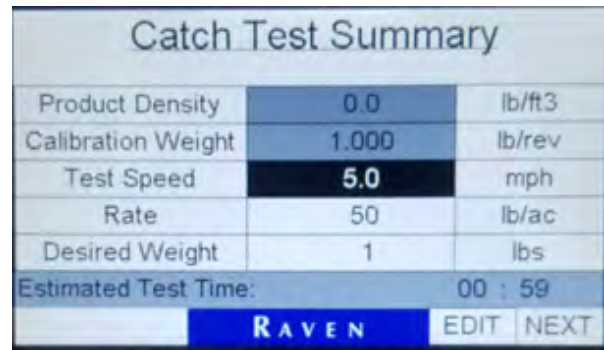

Fig. 27

6. Catch Test Summary;
 - a. Select Edit
 - b. Enter a Test Speed
 - i. Highlight the field and press "ok" to enter a value.
 - ii. Approximately the speed at which you will be seeding.
 - c. Enter Rate at which you will be applying that product.
 - i. Highlight the field and press "ok" to enter value.
 - d. Enter Desired weight to be dispense
 - i. Highlight the field and press "ok" to enter a value.
 - ii. Recommended to catch 15-25 lbs of product.
 - iii. No less than 10lbs.
7. Select Next.
8. Select Prime;
 - a. The Meter will turn 1 revolution
 - b. It is suggested to Prime (1) 2-3 times to ensure the meter is full of product.
9. Empty Calibration hang back under the desired meter and begin Calibration.



Catch Test Summary		
Product Density	0.0	lb/ft ³
Calibration Weight	1.000	lb/rev
Test Speed	5.0	mph
Rate	50	lb/ac
Desired Weight	1	lbs
Estimated Test Time:		00 : 59
RAVEN EDIT NEXT		

Fig. 28

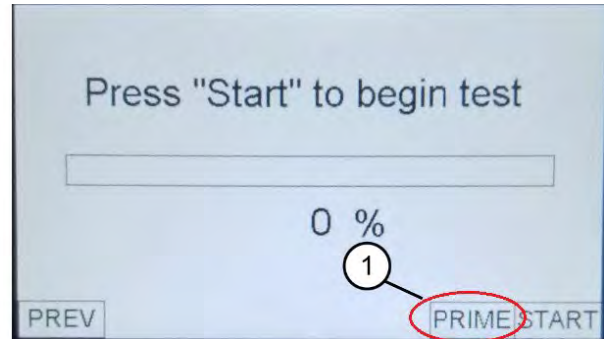

Fig. 29

3.11.3 Taking a product sample for calibration

1. Hang Calibration bag under meter being calibrated
2. Press Start (1).
3. When Calibration is complete you will be prompted to enter Actual Amount Applied;
 - a. Use arrow pad to enter value measured using scale provided in the calibration kit.
 - b. When measuring, be sure to have zeroed the scale with the bag weight in account.
 - c. Be sure the scale is in "lbs".

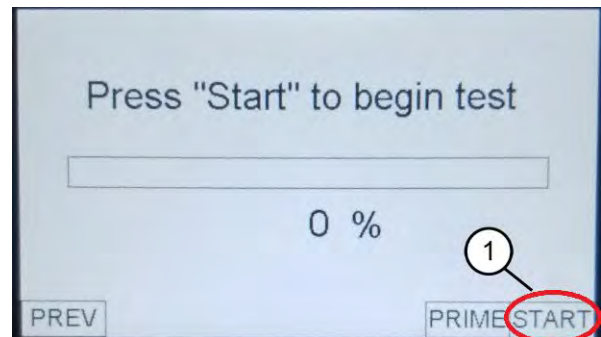

Fig. 30

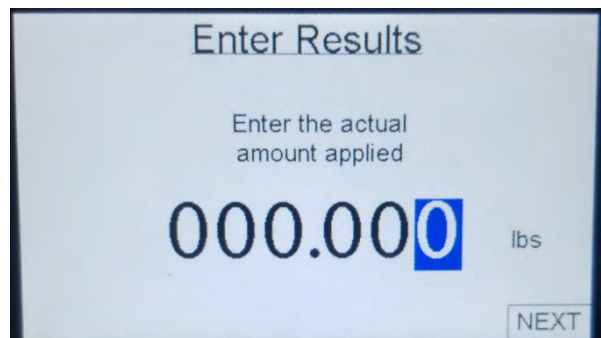

Fig. 31

4. Review the Catch Test Results:
 - a. The results may vary based on initial values.

5. It is suggested that you recalibrate after you received the results. This allows for the machine to make the adjustments and obtain a more accurate calibration number.

6. Press OK

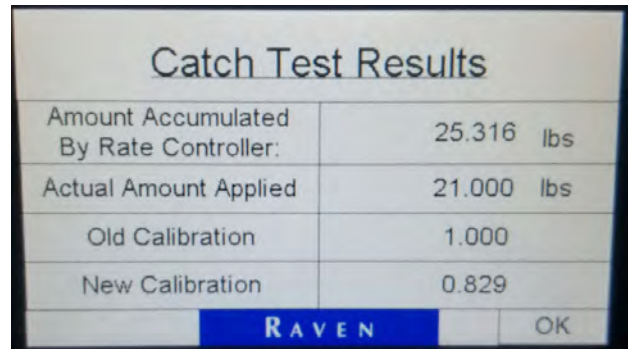
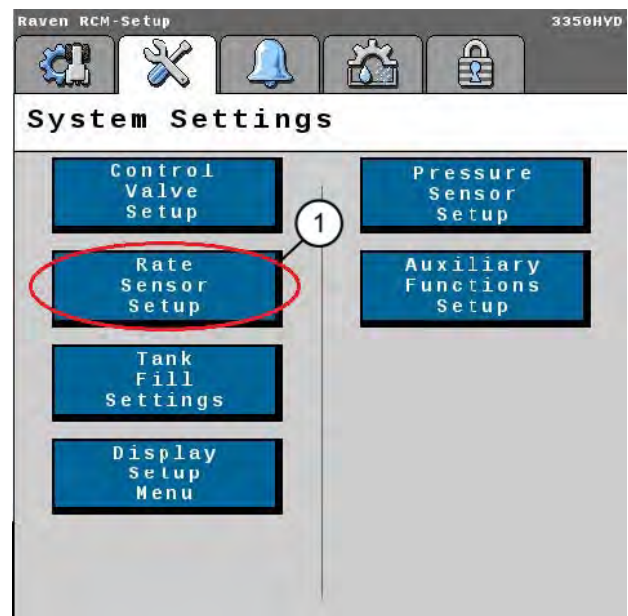

Fig. 32

3.11.3 Taking a product sample for calibration from Field Computer (In Cab)

If the auxiliary display is not available the calibration process can be completed from the In-Cab Field Computer

1. Select the Settings and select System Settings
2. Rate Sensor Set up (1).



3. Enter a Calibration Value based on door opening.
4. If the product density is known, enter it for the desired product.
Do not Change the Product Density After Calibrating - The calibration number will change
5. Select Catch Test Calibration.
6. Select Check Mark (1).



A warning screen will alarm, read and take note of the warning statement

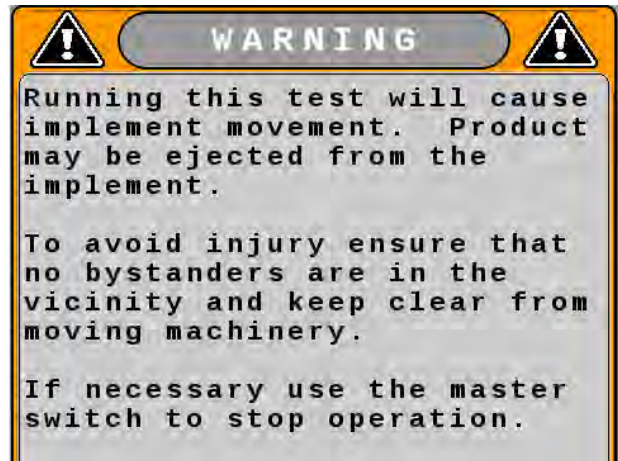

7. Calibrate Rate Sensor:

- a. Enter Test Speed:
 - i. Approximately the speed at which you will be seeding.
- b. Enter Rate at which you will be applying that product.
- c. Enter weight to be dispense;
 - i. Recommended to catch 15/25 lbs of product.
 - ii. No Less than 10lbs.
- d. Select Next.

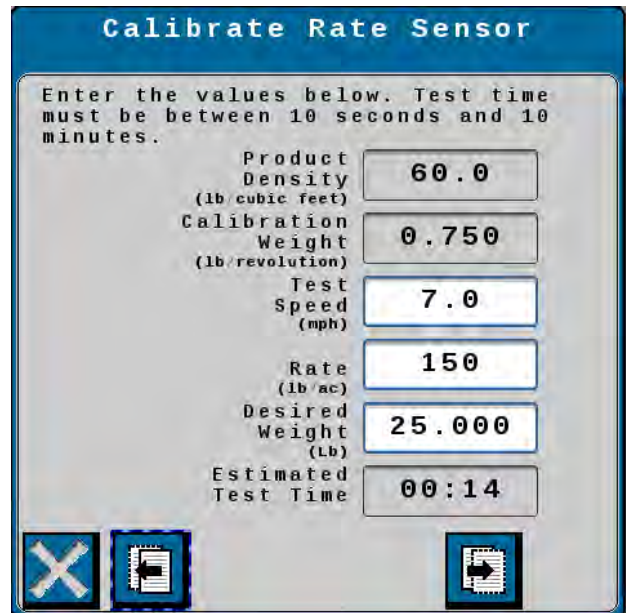

8. Hang the bag under the product you wish to calibrate.

9. If your Master Switch is not on, the Field Computer will display MASTER OFF (1).

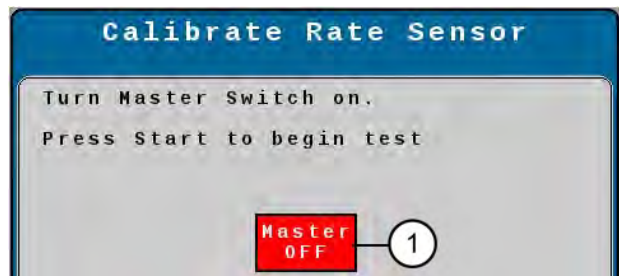

When On, the Start button (1) will appear,

- a. Select and the status bar will start to load.

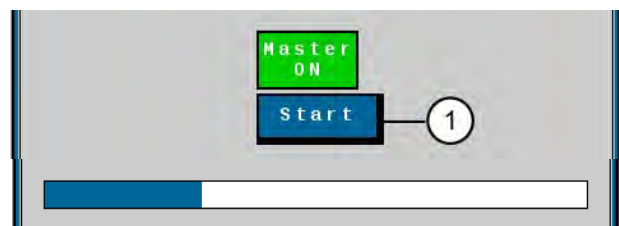

10. When complete, the Field Computer will prompt enter the catch weight:
- Enter this in lbs - tenths.
 - Be sure the bag weight is removed.

Calibrate Rate Sensor

Enter amount of product applied and accept new calibration value.

Amount Accumulated By Rate Controller (Lb)	25.375
Actual Amount Applied (Lb)	0.000
Old Calibration Weight	0.750
New Calibration Weight	0.000

Product 1 Granular

Navigation icons: Cancel (X) and OK (checkmark)

11. Review the Catch Test Results:
- The results may vary based on initial values.

12. It is suggested that you recalibrate after you received the results. This allows for the machine to make the adjustments and obtain a more accurate calibration number.

13. Press OK.

Calibrate Rate Sensor

Enter amount of product applied and accept new calibration value.

Amount Accumulated By Rate Controller (Lb)	25.375
Actual Amount Applied (Lb)	25.000
Old Calibration Weight	0.750
New Calibration Weight	0.739

Product 1 Granular

Navigation icons: Cancel (X) and OK (checkmark)

3.11.5 Manually setting the motor cal value for a variable rate system

Procedure

1. Select **PR1** (1) for the desired bin:
2. Select the Calibration Weight (2).
3. Enter the desired calibration weight (2).
The calibration weight is the amount of product applied per revolution on the meter roller. The calibration weight is calculated using the accumulated weight value (2) and the revolutions of the meter. If the motor spins 10 revolutions and accumulates 10 pounds, the calibration weight value is 1.000.

Do not Change the Product Density After Calibrating - The calibration number will change.

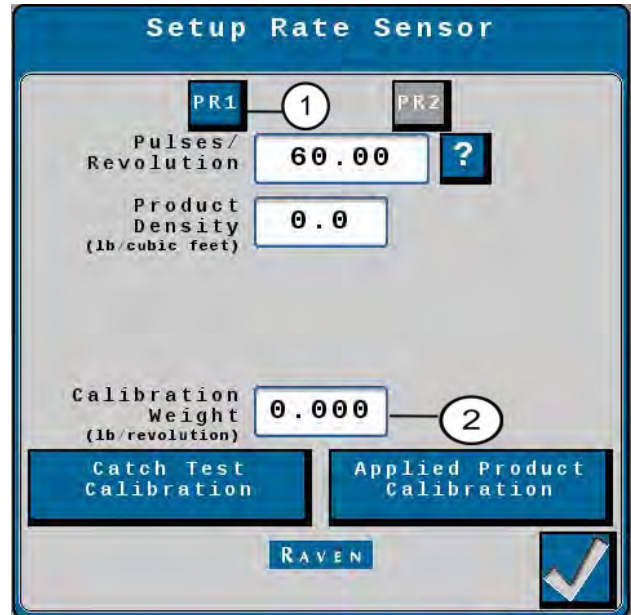

3.12 Rate charts

3.12.1 Fertilizer rate chart - 96 kg per cubic meter (60 lb per cubic foot)

Use the high capacity meter roll (1), part number 65705, with 12.27 mm (0.483 in) deep (A) x 16.74 mm (0.659 in) wide (B) flutes (2). The high capacity meter roll has 6 mm (0.25 in) wide x 13 mm (0.5 in) high bars (3).

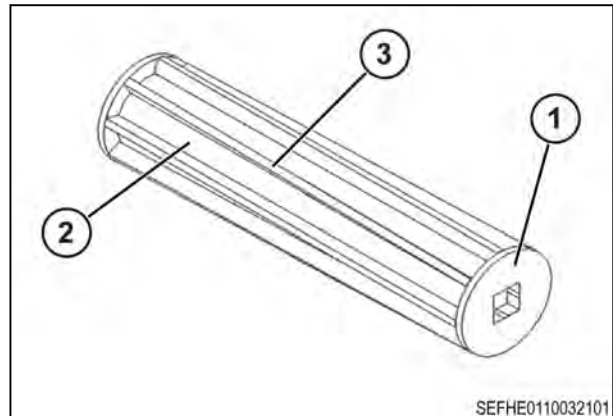

Fig. 27

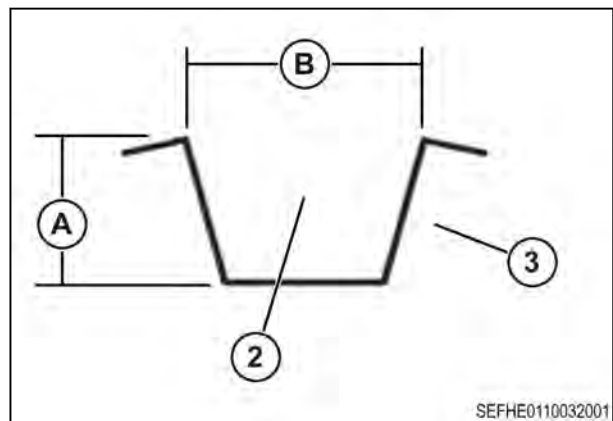

Fig. 28

This table applies to ground drive machines with: 17 tooth gear box sprocket and 18.4R26 tires, or 15 tooth gear box sprocket and 23.1R26 tires. This table does not apply to other gear box sprocket or tire sizes.

Width m (ft).	6.1m (20 ft)	7.6m (25 ft)	9.1m (30 ft)	10.7m (35 ft)	12.2m (40 ft)	13.7m (45 ft)	15.2m (50 ft)	16.8m (55 ft)	18.3m (60 ft)
Read across.									
Application rate in kg/ha (lb/acre). Read down.	Approximate pointer setting in inches.								
67 kg/ha (60 lb/acre)	(2.3 in)	(2.9 in)	(3.5 in)	(4.0 in)	(4.6 in)	(5.2 in)	(5.8 in)	(6.3 in)	(6.9 in)
78 kg/ha (70 lb/acre)	(2.7 in)	(3.4 in)	(4.0 in)	(4.7 in)	(5.4 in)	(6.0 in)	(6.7 in)	(7.4 in)	(8.1 in)

90 kg/ha (80 lb/acre)	(3.1 in)	(3.8 in)	(4.6 in)	(5.4 in)	(6.1 in)	(6.9 in)	(7.7 in)	(8.4 in)	(9.2 in)
101 kg/ha (90 lb/acre)	(3.5 in)	(4.3 in)	(5.2 in)	(6.0 in)	(6.9 in)	(7.8 in)	(8.6 in)	(9.5 in)	(10.4 in)
112 kg/ha (100 lb/acre)	(3.8 in)	(4.8 in)	(5.8 in)	(6.7 in)	(7.7 in)	(8.6 in)	(9.6 in)	(10.6 in)	(11.5 in)
123 kg/ha (110 lb/acre)	(4.2 in)	(5.3 in)	(6.3 in)	(7.4 in)	(8.4 in)	(9.5 in)	(10.6 in)	(11.6 in)	(12.7 in)
135 kg/ha (120 lb/acre)	(4.6 in)	(5.8 in)	(6.9 in)	(8.1 in)	(9.2 in)	(10.4 in)	(11.5 in)	(12.7 in)	(13.8 in)
146 kg/ha (130 lb/acre)	(5.0 in)	(6.2 in)	(7.5 in)	(8.7 in)	(10.0 in)	(11.2 in)	(12.5 in)	(13.7 in)	
157 kg/ha (140 lb/acre)	(5.4 in)	(6.7 in)	(8.1 in)	(9.4 in)	(10.8 in)	(12.1 in)	(13.4 in)		
168 kg/ha (150 lb/acre)	(5.8 in)	(7.2 in)	(8.6 in)	(10.1 in)	(11.5 in)	(13.0 in)			
179 kg/ha (160 lb/acre)	(6.1 in)	(7.7 in)	(9.2 in)	(10.8 in)	(12.3 in)	(13.8 in)			
191 kg/ha (170 lb/acre)	(6.5 in)	(8.2 in)	(9.8 in)	(11.4 in)	(13.1 in)				
202 kg/ha (180 lb/acre)	(6.9 in)	(8.6 in)	(10.4 in)	(12.1 in)	(13.8 in)				
213 kg/ha (190 lb/acre)	(7.3 in)	(9.1 in)	(10.9 in)	(12.8 in)					
224 kg/ha (200 lb/acre)	(7.7 in)	(9.6 in)	(11.5 in)	(13.4 in)					
235 kg/ha (210 lb/acre)	(8.1 in)	(10.1 in)	(12.1 in)						

247 kg/ha (220 lb/acre)	(8.4 in)	(10.6 in)	(12.7 in)						
258 kg/ha (230 lb/acre)	(8.8 in)	(11.0 in)	(13.2 in)						
269 kg/ha (240 lb/acre)	(9.2 in)	(11.5 in)	(13.8 in)						

3.12.2 Barley rate chart

Use the high capacity meter roll (1), part number 65705, with 12.27 mm (0.483 in) deep (A) x 16.74 mm (0.659 in) wide (B) flutes (2). The high capacity meter roll has 6 mm (0.25 in) wide x 13 mm (0.5 in) high bars (3).

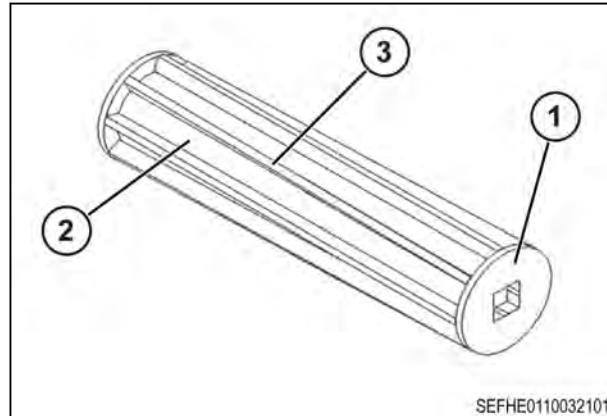

Fig. 29

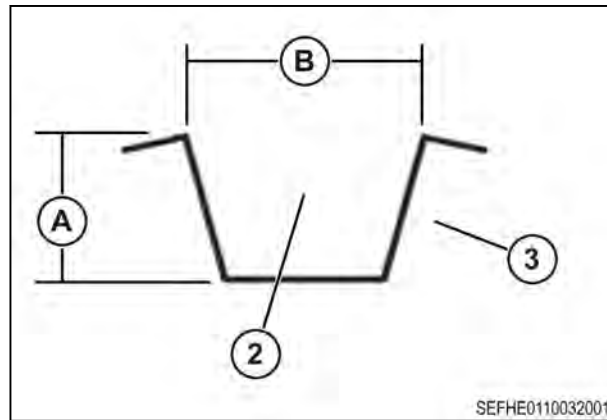

Fig. 30

This table applies to ground drive machines with: 17 tooth gear box sprocket and 18.4R26 tires, or 15 tooth gear box sprocket and 23.1R26 tires. This table does not apply to other gear box sprocket or tire sizes.

Width m (ft). Read across.	6.1m (20 ft)	7.6m (25 ft)	9.1m (30 ft)	10.7m (35 ft)	12.2m (40 ft)	13.7m (45 ft)	15.2m (50 ft)	16.8m (55 ft)	18.3m (60 ft)
Application rate in kg/ha (lb/acre). Read down.	Approximate pointer setting in inches.								
67 kg/ha (60 lb/acre)	(3.4 in)	(4.2 in)	(5.0 in)	(5.9 in)	(6.7 in)	(7.5 in)	(8.4 in)	(9.2 in)	(10.1 in)
78 kg/ha (70 lb/acre)	(3.9 in)	(4.9 in)	(5.8 in)	(6.8 in)	(7.8 in)	(8.8 in)	(9.8 in)	(10.7 in)	(11.7 in)
90 kg/ha (80 lb/acre)	(4.5 in)	(5.6 in)	(6.7 in)	(7.8 in)	(8.9 in)	(10.0 in)	(11.1 in)	(12.2 in)	(13.4 in)
101 kg/ha (90 lb/acre)	(5.0 in)	(6.3 in)	(7.6 in)	(8.8 in)	(10.1 in)	(11.4 in)	(12.6 in)	(13.9 in)	
112 kg/ha (100 lb/acre)	(5.6 in)	(7.0 in)	(8.4 in)	(9.8 in)	(11.2 in)	(12.6 in)	(14.0 in)		
123 kg/ha (110 lb/acre)	(6.2 in)	(7.7 in)	(9.2 in)	(10.8 in)	(12.3 in)	(13.8 in)			
135 kg/ha (120 lb/acre)	(6.7 in)	(8.4 in)	(10.1 in)	(11.7 in)	(13.4 in)				
146 kg/ha (130 lb/acre)	(7.3 in)	(9.1 in)	(10.9 in)	(12.8 in)					
157 kg/ha (140 lb/acre)	(7.8 in)	(9.8 in)	(11.8 in)	(13.7 in)					
168 kg/ha (150 lb/acre)	(8.4 in)	(10.5 in)	(12.6 in)						
179 kg/ha (160 lb/acre)	(8.9 in)	(11.2 in)	(13.4 in)						
191 kg/ha (170 lb/acre)	(9.5 in)	(11.9 in)							
202 kg/ha (180 lb/acre)	(10.1 in)	(12.6 in)							

213 kg/ha (190 lb/acre)	(10.7 in)	(13.3 in)							
224 kg/ha (200 lb/acre)	(11.2 in)								
235 kg/ha (210 lb/acre)	(11.8 in)								
247 kg/ha (220 lb/acre)	(12.3 in)								
258 kg/ha (230 lb/acre)	(12.9 in)								
269 kg/ha (240 lb/acre)	(13.4 in)								

3.12.3 Canola rate chart

Use the fine product meter roll (1), part number 67639, with 3 mm (0.125 in) deep (A) x 13 mm (0.5 in) wide (B) x 25.4 mm (1 in) long (C) slots (2).

The slots have a 38.1 mm (1.5 in) offset from slot to slot within rows.

The slots have an 8 mm (0.313 in) curve (D).

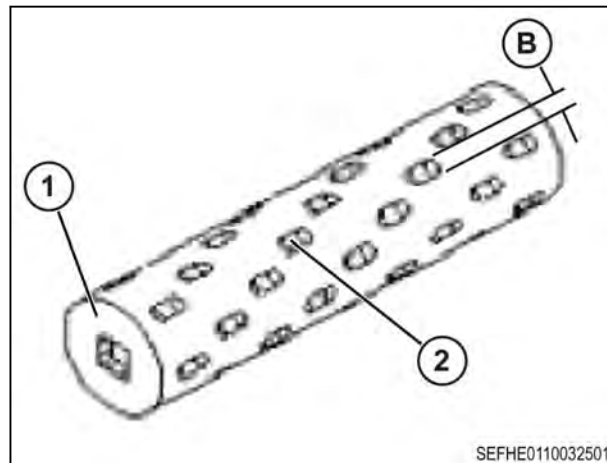

Fig. 31

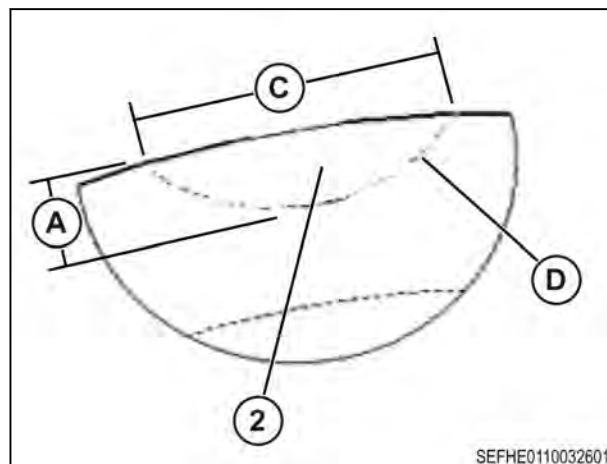

Fig. 32

This table applies to ground drive machines with: 17 tooth gear box sprocket and 18.4R26 tires, or 15 tooth gear box sprocket and 23.1R26 tires. This table does not apply to other gear box sprocket or tire sizes.

Width m (ft). Read across.	6.1m (20 ft)	7.6m (25 ft)	9.1m (30 ft)	10.7m (35 ft)	12.2m (40 ft)	13.7m (45 ft)	15.2m (50 ft)	16.8m (55 ft)	18.3m (60 ft)
Application rate in kg/ha (lb/acre). Read down.	Approximate pointer setting in inches.								
1.36 kg/ha (3 lb/acre)							(0.4 in)	(0.9 in)	(1.4 in)
1.81 kg/ha (4 lb/acre)					(0.8 in)	(1.4 in)	(2.1 in)	(2.8 in)	(3.5 in)
2.27 kg/ha (5 lb/acre)			(0.4 in)	(1.3 in)	(2.1 in)	(3.0 in)	(3.9 in)	(4.7 in)	(5.6 in)
2.72 kg/ha (6 lb/acre)		(0.4 in)	(1.4 in)	(2.5 in)	(3.5 in)	(4.5 in)	(5.6 in)	(6.6 in)	(7.6 in)
3.18 kg/ha (7 lb/acre)		(1.3 in)	(2.5 in)	(3.7 in)	(4.9 in)	(6.1 in)	(7.3 in)	(8.5 in)	(9.7 in)
3.63 kg/ha (8 lb/acre)	(0.8 in)	(2.1 in)	(3.5 in)	(4.9 in)	(6.3 in)	(7.6 in)	(9.0 in)	(10.4 in)	(11.8 in)
4.08 kg/ha (9 lb/acre)	(1.4 in)	(3.0 in)	(4.5 in)	(6.2 in)	(7.6 in)	(9.2 in)	(10.7 in)	(12.3 in)	
4.54 kg/ha (10 lb/acre)	(2.1 in)	(3.9 in)	(5.6 in)	(7.3 in)	(9.0 in)	(10.7 in)	(12.5 in)		
4.99 kg/ha (11 lb/acre)	(2.8 in)	(4.7 in)	(6.6 in)	(8.5 in)	(10.4 in)	(12.3 in)			
5.44 kg/ha (12 lb/acre)	(3.5 in)	(5.6 in)	(7.6 in)	(9.7 in)	(11.8 in)				
5.90 kg/ha (13 lb/acre)	(4.2 in)	(6.4 in)	(8.7 in)	(10.9 in)	(13.1 in)				
6.35 kg/ha (14 lb/acre)	(4.9 in)	(7.3 in)	(9.7 in)	(12.1 in)					
6.80 kg/ha (15 lb/acre)	(5.6 in)	(8.2 in)	(10.7 in)	(13.3 in)					

3.12.4 Soybean rate chart

Use the high capacity meter roll (1), part number 65705, with 12.27 mm (0.483 in) deep (A) x 16.74 mm (0.659 in) wide (B) flutes (2). The high capacity meter roll has 6 mm (0.25 in) wide x 13 mm (0.5 in) high bars (3).

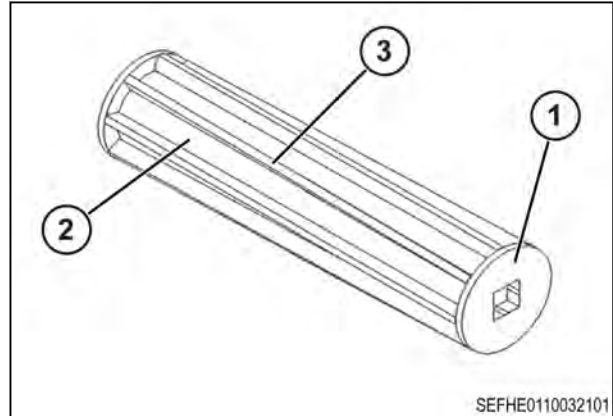

Fig. 33

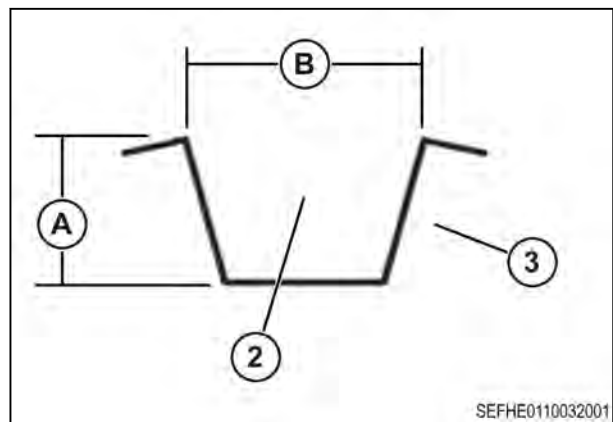

Fig. 34

This table applies to ground drive machines with: 17 tooth gear box sprocket and 18.4R26 tires, or 15 tooth gear box sprocket and 23.1R26 tires. This table does not apply to other gear box sprocket or tire sizes.

Width m (ft).	6.1m (20 ft)	7.6m (25 ft)	9.1m (30 ft)	10.7m (35 ft)	12.2m (40 ft)	13.7m (45 ft)	15.2m (50 ft)	16.8m (55 ft)	18.3m (60 ft)
Read across.									
Application rate in kg/ha (lb/acre). Read down.	Approximate pointer setting in inches.								
67 kg/ha (60 lb/acre)	(3.1 in)	(3.9 in)	(4.7 in)	(5.4 in)	(6.2 in)	(7.0 in)	(7.8 in)	(8.5 in)	(9.3 in)
78 kg/ha (70 lb/acre)	(3.6 in)	(4.5 in)	(5.4 in)	(6.3 in)	(7.2 in)	(8.1 in)	(9.1 in)	10.0 in	10.9 in
90 kg/ha (80 lb/acre)	(4.1 in)	(5.2 in)	(6.2 in)	(7.2 in)	(8.3 in)	(9.3 in)	10.3 in	(11.4 in)	(12.4 in)

101 kg/ ha (90 lb/ acre)	(4.6 in)	(5.8 in)	(6.9 in)	(8.0 in)	(9.2 in)	10.4 in)	(11.5 in)	(12.6 in)	(13.8 in)
112 kg/ ha (100 lb/acre)	(5.2 in)	(6.4 in)	(7.7 in)	(9.0 in)	10.3 in)	(11.6 in)	(12.9 in)	(14.2 in)	
123 kg/ ha (110 lb/acre)	(5.7 in)	(7.1 in)	(8.6 in)	10.0 in)	(11.4 in)	(12.8 in)	(14.0 in)		
135 kg/ ha (120 lb/acre)	(6.2 in)	(7.8 in)	(9.3 in)	10.9 in)	(12.4 in)	(14.0 in)			
146 kg/ ha (130 lb/acre)	(6.7 in)	(8.4 in)	10.1 in)	(11.7 in)	(13.4 in)				
157 kg/ ha (140 lb/acre)	(7.2 in)	(9.0 in)	10.8 in)	(12.6 in)					
168 kg/ ha (150 lb/acre)	(7.7 in)	(9.6 in)	(11.6 in)	(13.5 in)					
179 kg/ ha (160 lb/acre)	(8.2 in)	10.3 in)	(12.3 in)						
191 kg/ ha (170 lb/acre)	(8.8 in)	10.9 in)	(13.1 in)						
202 kg/ ha (180 lb/acre)	(9.3 in)	(11.6 in)	(13.9 in)						
213 kg/ ha (190 lb/acre)	(9.8 in)	(12.2 in)							
224 kg/ ha (200 lb/acre)	10.4 in)	(12.9 in)							
235 kg/ ha (210 lb/acre)	10.9 in)	(13.6 in)							
247 kg/ ha (220 lb/acre)	(11.4 in)								
258 kg/ ha (230 lb/acre)	(11.9 in)								
269 kg/ ha (240 lb/acre)	(12.4 in)								

3.12.5 Wheat rate chart

Use the high capacity meter roll (1), part number 65705, with 12.27 mm (0.483 in) deep (A) x 16.74 mm (0.659 in) wide (B) flutes (2). The high capacity meter roll has 6 mm (0.25 in) wide x 13 mm (0.5 in) high bars (3).

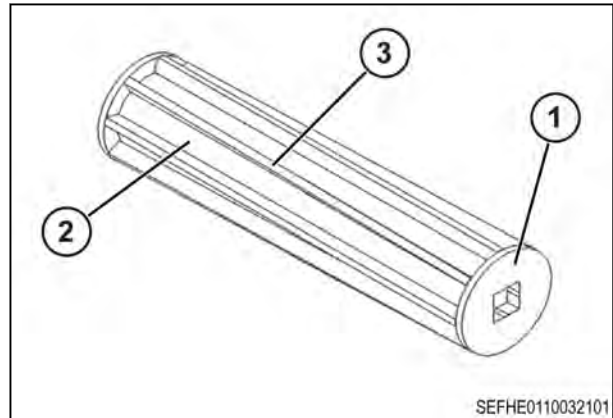

Fig. 35

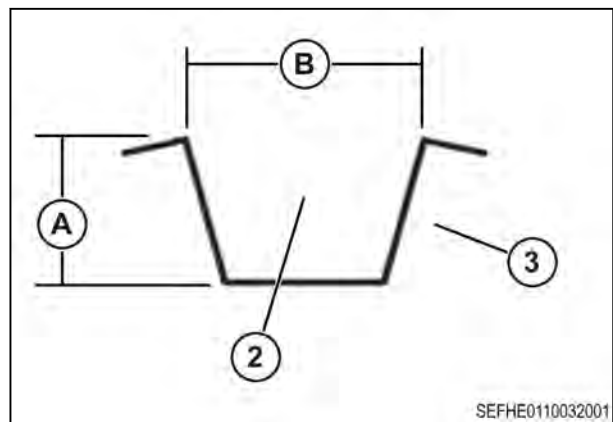

Fig. 36

This table applies to ground drive machines with: 17 tooth gear box sprocket and 18.4R26 tires, or 15 tooth gear box sprocket and 23.1R26 tires. This table does not apply to other gear box sprocket or tire sizes.

Width m (ft).	6.1m (20 ft)	7.6m (25 ft)	9.1m (30 ft)	10.7m (35 ft)	12.2m (40 ft)	13.7m (45 ft)	15.2m (50 ft)	16.8m (55 ft)	18.3m (60 ft)
Read across.									
Application rate in kg/ha (lb/acre). Read down.	Approximate pointer setting in inches.								
67 kg/ha (60 lb/acre)	(2.7 in)	(3.4 in)	(4.1 in)	(4.7 in)	(5.4 in)	(6.1 in)	(6.8 in)	(7.4 in)	(8.1 in)
78 kg/ha (70 lb/acre)	(3.1 in)	(3.9 in)	(4.7 in)	(5.5 in)	(6.3 in)	(7.1 in)	(7.9 in)	(8.7 in)	(9.4 in)
90 kg/ha (80 lb/acre)	(3.6 in)	(4.5 in)	(5.4 in)	(6.3 in)	(7.2 in)	(8.1 in)	(9.0 in)	(9.9 in)	(10.8 in)

101 kg/ ha (90 lb/ acre)	(4.0 in)	(5.0 in)	(6.0 in)	(7.0 in)	(8.0 in)	(9.0 in)	(10.0 in)	(11.0 in)	(12.0 in)
112 kg/ ha (100 lb/acre)	(4.5 in)	(5.6 in)	(6.8 in)	(7.9 in)	(9.0 in)	(10.1 in)	(11.3 in)	(12.4 in)	(13.5 in)
123 kg/ ha (110 lb/acre)	(5.0 in)	(6.2 in)	(7.4 in)	(8.7 in)	(9.9 in)	(11.1 in)	(12.4 in)	(13.6 in)	
135 kg/ ha (120 lb/acre)	(5.4 in)	(6.8 in)	(8.1 in)	(9.5 in)	(10.8 in)	(12.2 in)	(13.5 in)		
146 kg/ ha (130 lb/acre)	(5.8 in)	(7.3 in)	(8.8 in)	(10.2 in)	(11.7 in)	(13.2 in)			
157 kg/ ha (140 lb/acre)	(6.3 in)	(7.8 in)	(9.4 in)	(10.9 in)	(12.5 in)				
179 kg/ ha (160 lb/acre)	(7.2 in)	(8.9 in)	(10.7 in)	(12.5 in)					
191 kg/ ha (170 lb/acre)	(7.6 in)	(9.5 in)	(11.4 in)	(13.3 in)					
202 kg/ ha (180 lb/acre)	(8.1 in)	(10.1 in)	(12.1 in)						
213 kg/ ha (190 lb/acre)	(8.5 in)	(10.6 in)	(12.8 in)						
224 kg/ ha (200 lb/acre)	(8.9 in)	(11.2 in)	(13.4 in)						
235 kg/ ha (210 lb/acre)	(9.4 in)	(11.8 in)							
247 kg/ ha (220 lb/acre)	(9.8 in)	(12.3 in)							
258 kg/ ha (230 lb/acre)	(10.3 in)	(12.9 in)							
269 kg/ ha (240 lb/acre)	(10.8 in)	(13.4 in)							

3.13 Control system

3.13.1 Control system overview

The air cart has an electronic system to monitor and control the machine functions. The ISO Monitor system is based on the ISO 11783 standard, also referred to as ISOBUS. ISOBUS is a communication standard that enables a variety of agricultural electronics systems to communicate to each other. The purpose is to integrate all current and future farm functions by standardizing communication between the tractor and implement. ISOBUS permits the use of the same tractor terminal on a number of different machines and control of a wide range of implements without the reprogramming a system.

3.13.2 System hardware

The ISO system includes an electronic control unit (ECU), which connects different sensors and an electric-over hydraulic (EOH) meter drive system. The ECU communicates with the virtual terminal (VT) located inside the tractor cab. The terminal shown information and enables the user to configure, calibrate, and operate multiple systems from a single user interface.

3.13.2.1 Raven electronic control unit

The ECU is mounted on the air system. The ECU monitors all system sensors and controls the meter drives. The ECU connects to the terminal in the tractor cab through a connecting cable that plugs into the front of the ECU on one end and into the standard ISOBUS connector on the tractor at the other end.

3.13.2.2 Virtual terminal

The virtual terminal (VT), also referred to as the terminal, in the tractor cab gives a user an interface for the system. The terminal communicates with the ECU and any other ISOBUS-compatible equipment connected to the system.

Several companies make ISOBUS-compatible virtual terminals. All terminals use the same screen icons to show the main functions. The control screens, or pages, for the implement (which are displayed in the center area of the screen) are the same for any ISOBUS-compatible terminal.

Contact the manufacturer of the virtual terminal on the tractor to make sure the terminal can be used with the ISO system on this machine.

3.13.2.3 Blower speed sensor

The blower speed sensor (1) is an inductive sensor on the blower fan. The blower speed sensor gives speed information to the ECU.

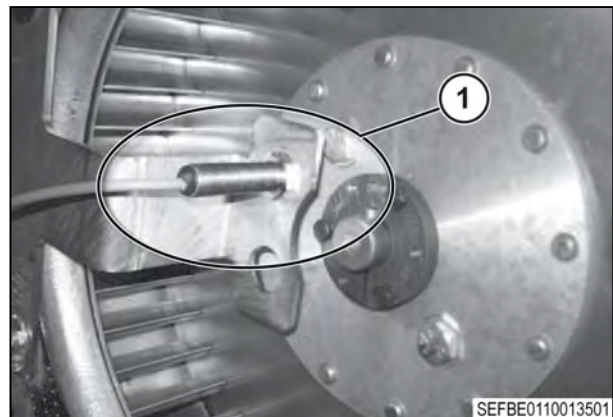

Fig. 37

3.13.2.4 Bin level sensor

Optional bin level sensors (1) indicate when the level of product in the bin has decreased to the level of the sensor. The same sensor senses all types of products.

The sensor height can be adjusted to set the alarm point at any desired level.

There also is an adjustment screw on the back of the sensor that can adjust the sensitivity for different products

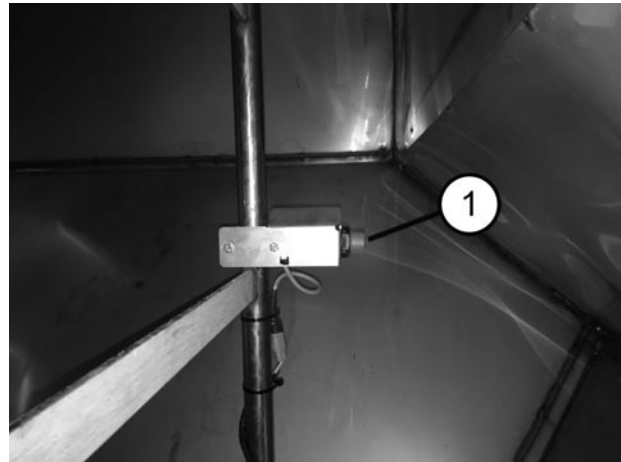

Fig. 38

3.13.2.5 Meter box flow sensor

The meter box flow sensor is a capacitive sensor that senses when the meter box is empty. The sensor indicates if the bin is completely empty, or if the product has stopped flowing into the meter box because of bridging or a leaky lid on the bin.

There also is an adjustment screw on the back of the sensor that can adjust the sensitivity for different products

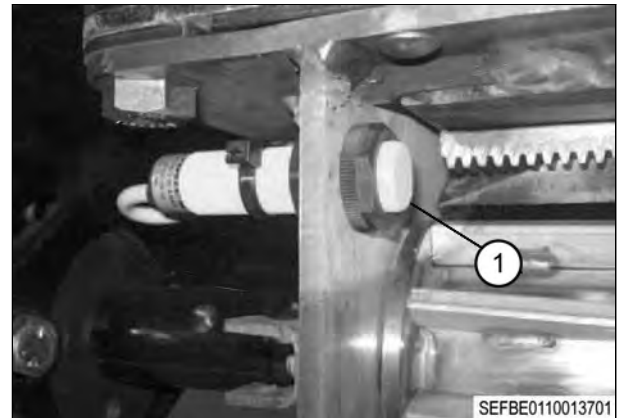

Fig. 39

3.13.2.6 Meter shaft speed sensor (ground drive)

The meter shaft speed sensor for ground drive units is a magnetic proximity sensor (1). The meter shaft speed sensor is used to sense the speed of the meter shaft. This information is used to calculate how much product has been applied and also indicate that the ground drive system is operating correctly.

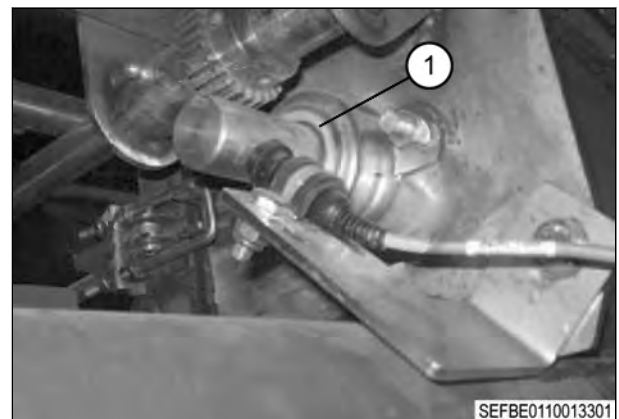

Fig. 40

3.13.2.7 Meter shaft speed sensor (hydraulic drive)

If the air system was bought with the hydraulic drive option, an internal meter shaft speed sensor (1) is included with the hydraulic motor. The meter shaft speed sensor gives accurate meter speed control that is necessary.

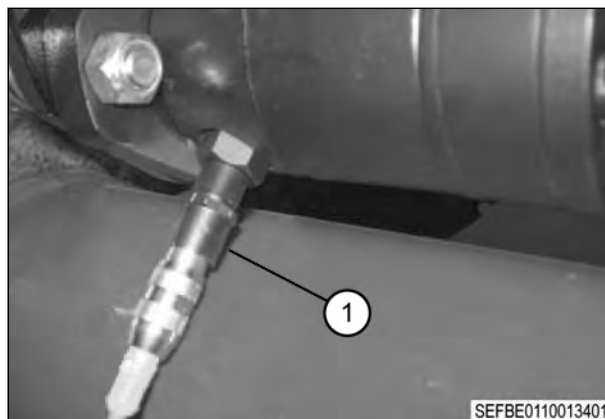

Fig. 41

3.14 Cart control system

3.14.1 Virtual terminal - cart control system

A ISOBUS-compatible terminal can communicate with the cart control system. When the terminal in the tractor is connected to the electronic control unit (ECU) on the cart, information automatically downloads. The information from the ECU will show on the terminal screen. The center of the terminal screen shows the information on all ISOBUS-compatible terminals.

Commonly, icons are located around or to the side of the center of the terminal screen. Selecting an icon will show another screen. The icon locations can vary with the terminal manufacturer. Some terminals are touch screens, and some have buttons next to the on-screen icons.

ISOBUS-compatible terminals can set up, operate, and monitor the cart control system. Specific terminal operation varies with each type of terminal. See the terminal operator manual for more information.

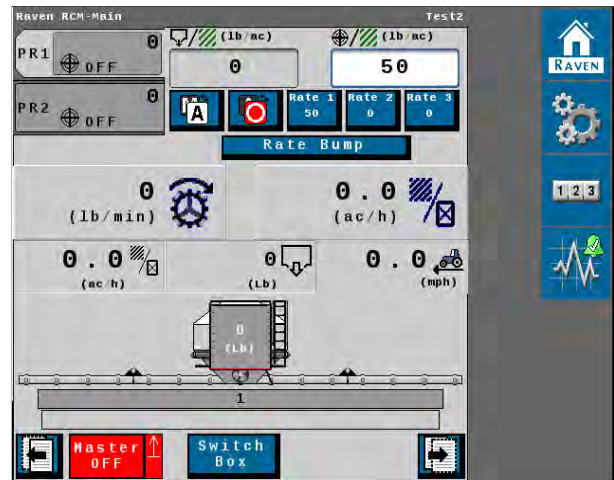
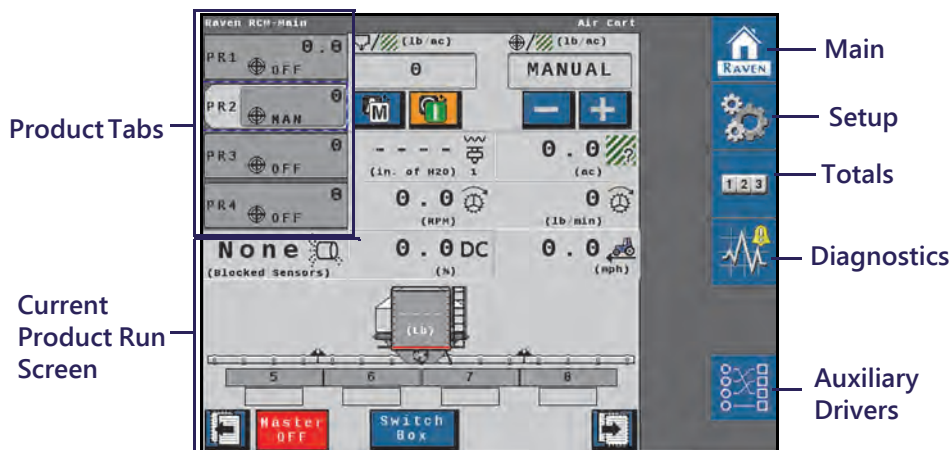

Fig. 43

3.14.4 Main (home) screen







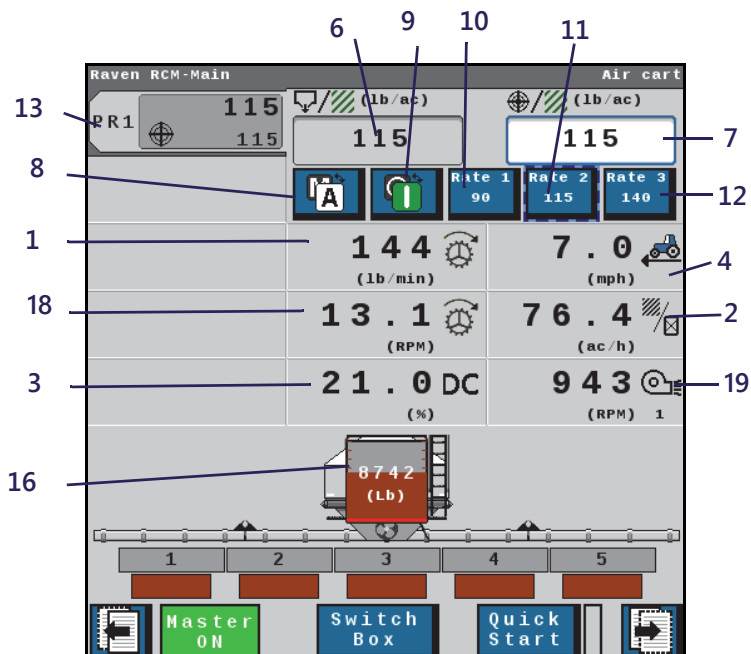





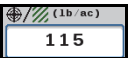



PRODUCT TABS

Press on the product tab to select the desired product. This will open the to product run screen for that product.

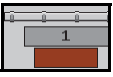

	Button	Description	Function/Operation
	1	Volume Per Minute	Indicates the application rate per minute.
	2	Area Per Hour	Indicates the how many acres per hour are being applied.
	3	PWM Readout	Shows the operating percentage of the PWM valve.
	4	Traveling Speed	Shows the implement/machine speed.

	Button	Description	Function/Operation
	5	Section Switchbox Button	Indicates if the switchbox is on or off: <ul style="list-style-type: none"> Green - On Red - Off
	6	Actual Rate	Displays the actual application rate.
	7	Target Rate	Displays the current target rate. The target rate can be adjusted by pressing in the number cell and entering a new number.
	8	Manual/Automatic Toggle	Press this to switch between manual and automatic operation.
	9	Product On/Off Toggle	Press this to manually turn a product on or off.
	10	Predefined Rate 1 Button	Select this button to start applying at the rate listed on the button. Refer to “Rates Setup” on page 28 for more information on adjusting rates.
	11	Predefined Rate 2 Button	Select this button to start applying at the rate listed on the button. Refer to “Rates Setup” on page 28 for more information on adjusting rates.
	12	Predefined Rate 3 Button	Select this button to start applying at the rate listed on the button. Refer to “Rates Setup” on page 28 for more information on adjusting rates.
	13	Product Tab	Select a tab to view information for that product.
	14	Quick Start Button	Press the quick start button to quickly configure a product.
	15	Master Switch Indicator	The Master Switch Indicator shows the status of the master switch. <ul style="list-style-type: none"> Green - On Red - Off Orange - Cycle the master switch
	16	Tank Level Indicator and Fill Button	Indicated the fill level of the tank.
	17	Implement Sections	Displays the section number. The section status will display below the implement section. <ul style="list-style-type: none"> Red - Off Green - On Blue - Liquid
	18	Meter Speed	Displays the current speed of the flowmeter.
	19	Fan Speed	Indicates the fan speed in RPM.

MAIN

Press MAIN (top screen on Page 90) at any time to return to the Current Product Run Screen.

SETUP

Pressing SETUP (top screen on Page 90) opens a screen with the tabs shown below.

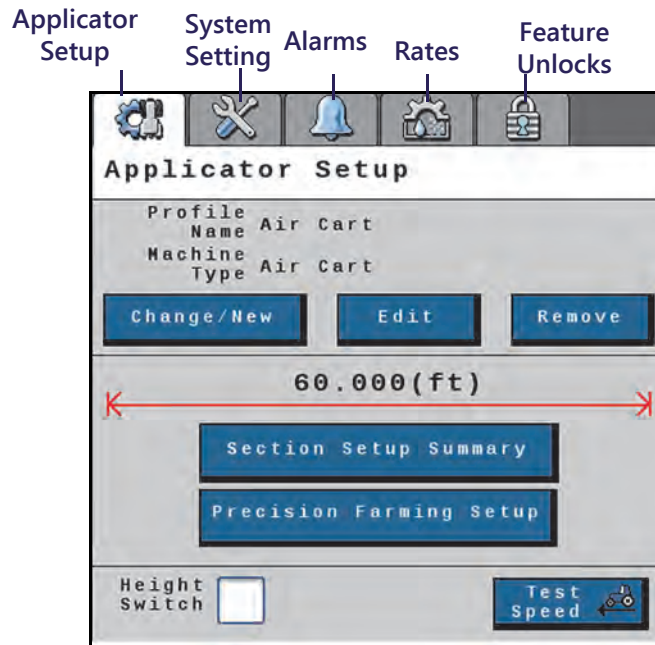

APPLICATOR SETUP TAB

The Applicator Setup Tab provides options to create a new, edit, or remove an applicator. This tab also provides a summary to the section configuration. For more information on the Precision Farming Setup button, refer to Chapter 9, Precision Farming.

SYSTEM SETTINGS

The system settings provides many buttons that allow the user to modify the current configuration. The table below describes each button in detail.

SYSTEM SETTINGS



Button	Description
Control Valve Setup	The Control Valve button allows the user to adjust the following settings for each product: <ul style="list-style-type: none"> • Valve Response Rate • Control Deadband • Valve Delay • Valve Advance • Control Effort
Rate Sensor Setup	The Rate Sensor Setup button provides the options to adjust the following settings: <ul style="list-style-type: none"> • Flowmeter Calibration • Flowmeter Pulse/Units • Flowmeter Low Limit • Tank Fill Flowmeter Calibration • Tank Fill Flowmeter Pulse/Units There is also the option to perform a catch test and applied product calibration.
Tank Fill Settings	This button allows the user to enter the Tank Capacity, Current Tank Level, and Low Tank Level.
Display Setup Menu	The Display Setup Menu allows the user to customize the main run screen object pool.
Pressure Sensor Setup	This button allows the user to modify the alarm Min and Max for any products that have pressure alarms selected.
Auxiliary Functions	The Auxiliary Functions button allows the user to create new or modify existing auxiliary functions.
Scale Setup	Scale Setup allows the user to configure scale options.

ALARM SETTINGS



Press the Alarm Settings tab to modify or update alarm settings such as Off Rate Alarm and the Minimum Flow Rate. There is also an option to update the Pressure Alarm.

RATES SETUP



The Rates Setup tab allows the user to adjust the Preset Rate Values, Rate Bump, Rate Selection, and other values entered during the original configuration.

FEATURE UNLOCKS



If there are additional features available for the RCM, enter the provided Activation Key to access these features.

TOTALS



The totals button provides options to access a Current Totals, Device totals, and Distance totals tabs.

DIAGNOSTICS

Selecting the Diagnostics button open a window with tabs for the items listed below.

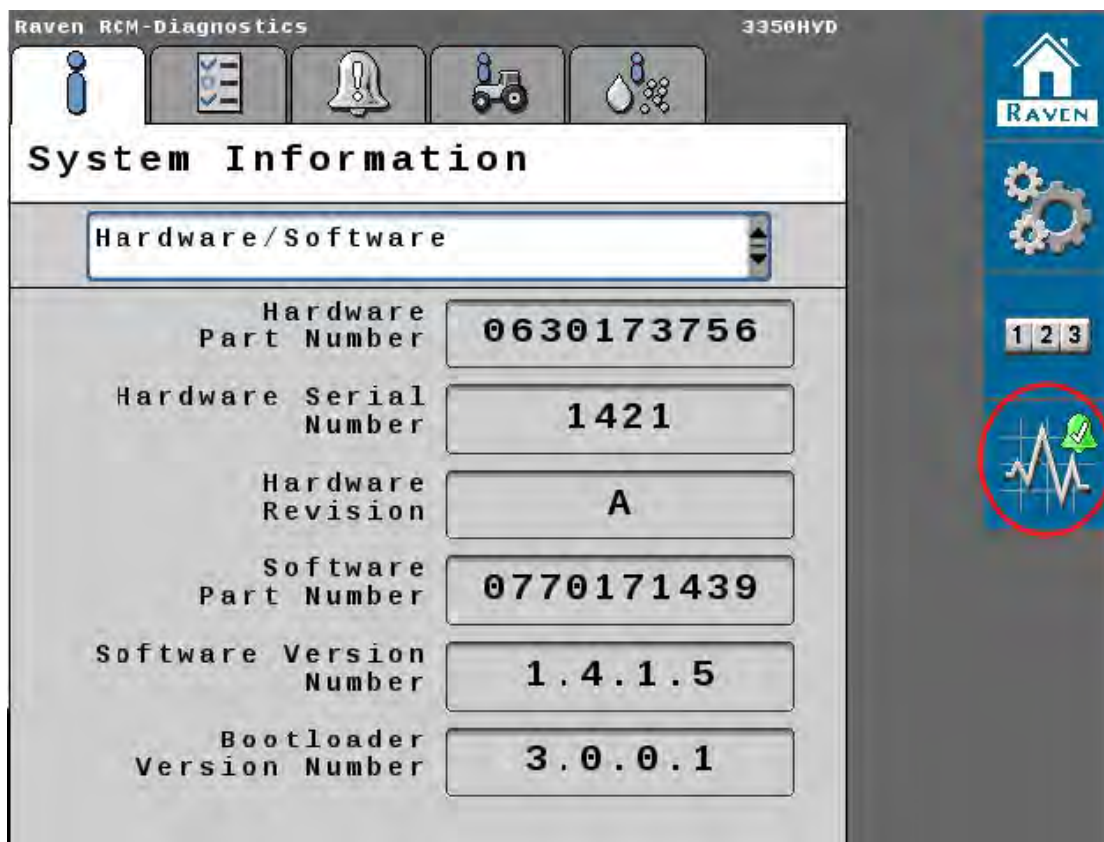

SYSTEM INFORMATION

Displays information about the RCM including the Hardware Serial Number, Hardware Revision, and Software Version Number.

TESTS

The Tests tab allows the user to select various tests from a drop down. These list of tests will vary by product configuration.

DIAGNOSTIC TROUBLE CODES

This tab lists Active and Inactive diagnostic trouble codes as well as the ability to Clear the active codes.

SYSTEM SUMMARY

Displays information configured during the setup process but does not provide the option to modify the configuration.

PRODUCT SUMMARY

The Product Summary provides a brief summary for all of the products such as Application Type, Control Valve type, Target Rate, and other settings. This tab does not allow the user to modify the configurations.

AUXILIARY DRIVERS

Auxiliary drivers that were created during configuration are listed in Auxiliary Drivers.

Machine Alarms

Alarms show up as separate screens and are acknowledged on the terminal. The alarms are notifications of an instance that happens on the machine that is not part of normal operation

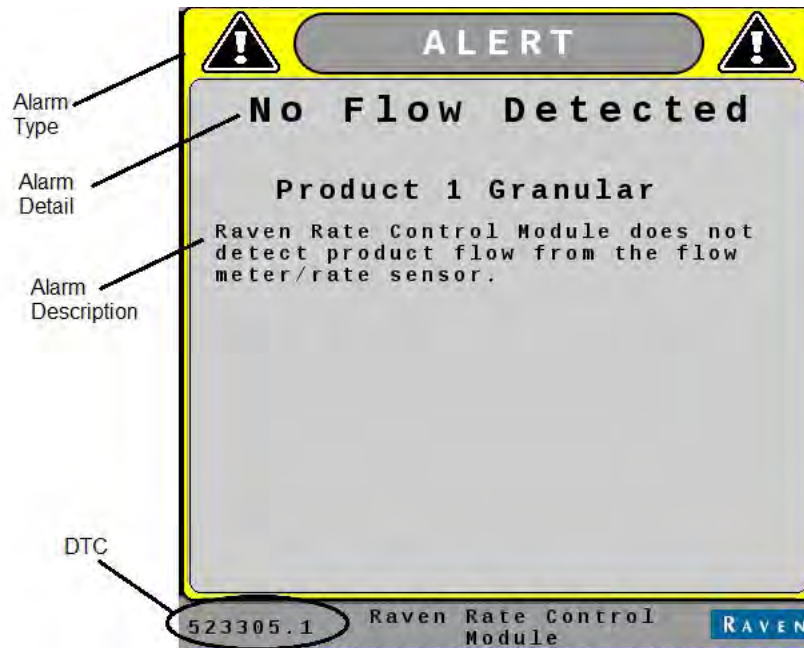

If the alarm is current and hasn't been tended to, it will be listed in the Active List in the Diagnostic Trouble Code list. If the alarm has been resolved, it will no longer be listed in the Active list, it will be stored in the Inactive list for reference.

Accessing Diagnostic Trouble Codes

1. Select the Diagnostics button.
2. Select the Diagnostic Trouble Codes (DTC) tab (1).
 - Current trouble codes appear in the Active table. The DTC Identification number and occurrence count is listed.
 - Resolved trouble codes appear in the Inactive table. The DTC Identification number and occurrence count is listed.
3. Use the up and down arrows to scroll through the list of trouble codes. A description of the highlighted code is shown below each table.
4. If desired, press the Clear button (2) to erase all the trouble codes listed in the Inactive table.

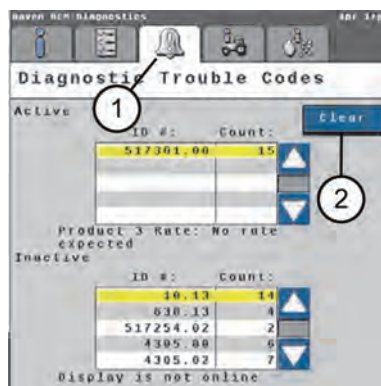

3.15 Profile set up

Before operating the cart control system, there are some setup and calibration procedures that must be done to make sure the seeding performance is correct. If these operations are not complete, seeding performance and accuracy will not be correct.

IMPORTANT:

The profile setup procedures must be completed or the system will not operate correctly. Complete all steps. (These steps should be preloaded onto the machine, if not, follow this procedure)

3.15.1 Profile Set Up (Ground Drive)

Upon initial start up, if no profile is loaded you will be prompted to set one up. Follow these steps to set up a Ground Drive Amity Air Cart

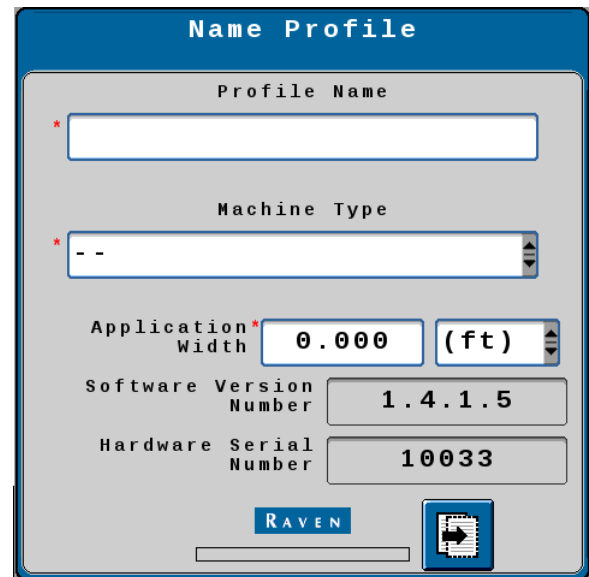

1. Enter Profile Name (Tank Size GD) GD = Ground Drive
Machine Type – Air Cart
Toolbar Width – Note the width can be entered in feet or inches
Select Next (1).

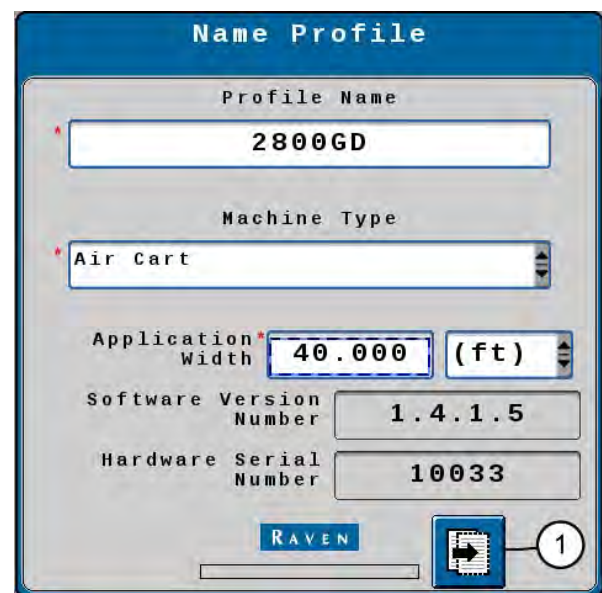

2. Enter Number of Products (Bins).
 Select Next (1) after completely each one of the following steps.
 Select return (2) to go back and edit a previous step.

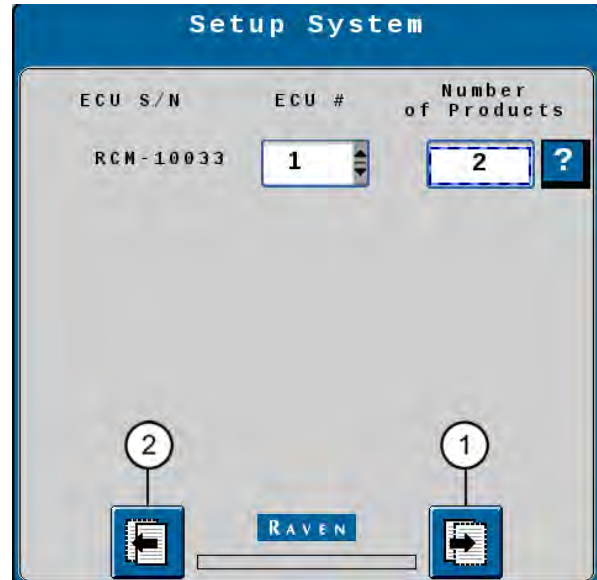

3. Select the Number of Fans on the Machine:

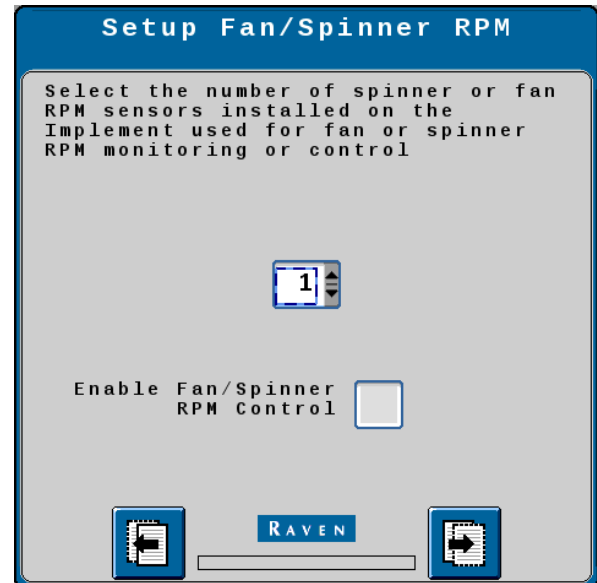

4. Select Product Type:

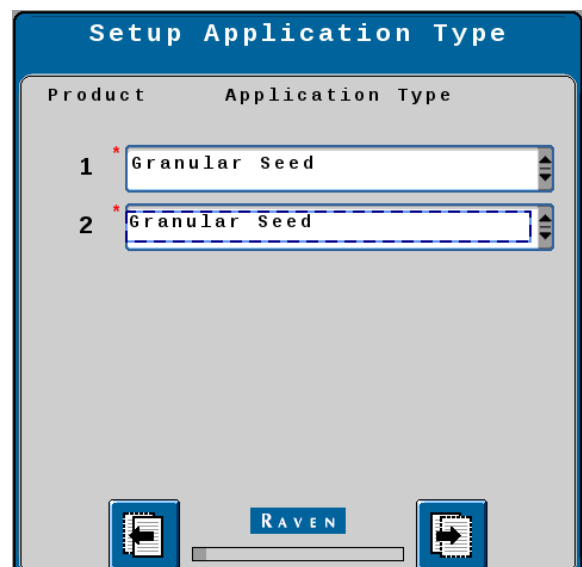

5. Select Application Mode for each product selected:

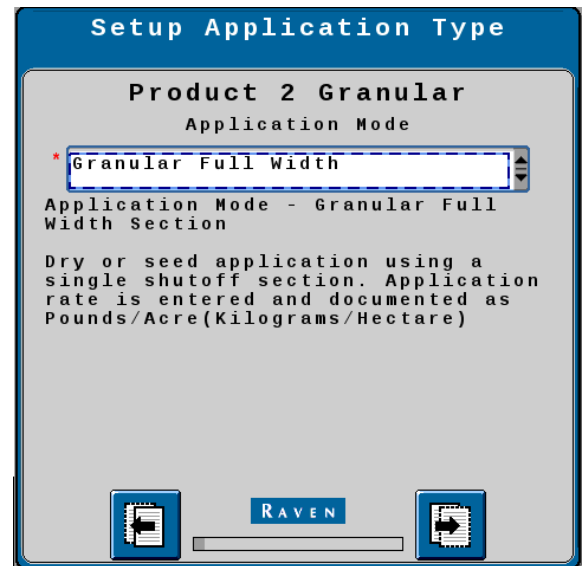
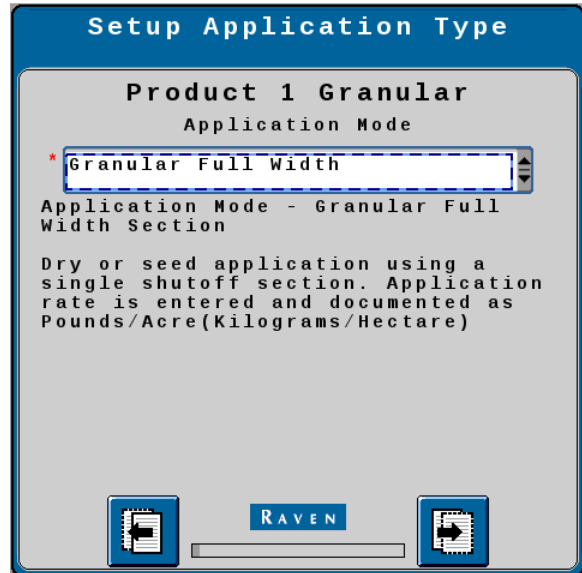

6. Ensure for Ground Drive "Master Clutch" is Selected:

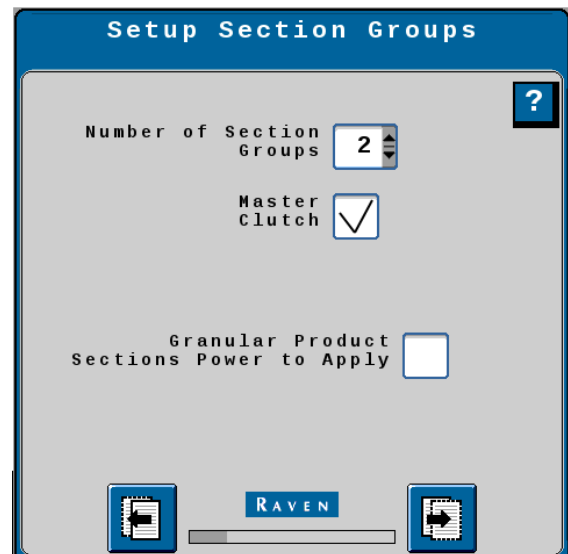

7. For our Machines, there are no Auxillary Drivers available:

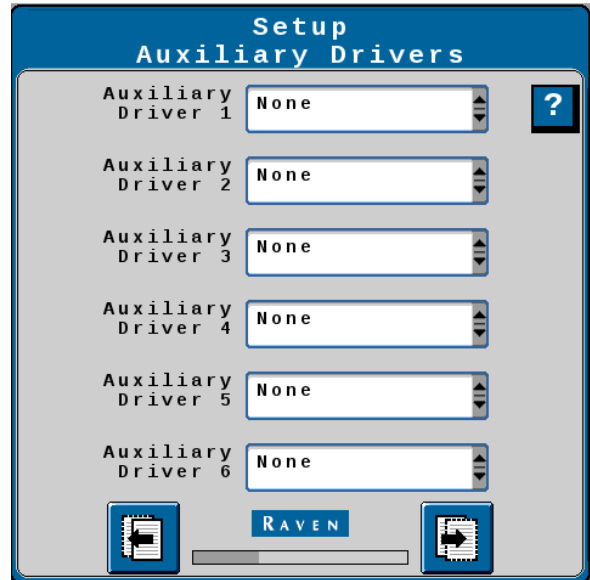

8. Review the Section Summary to ensure the widths and sections are correct:

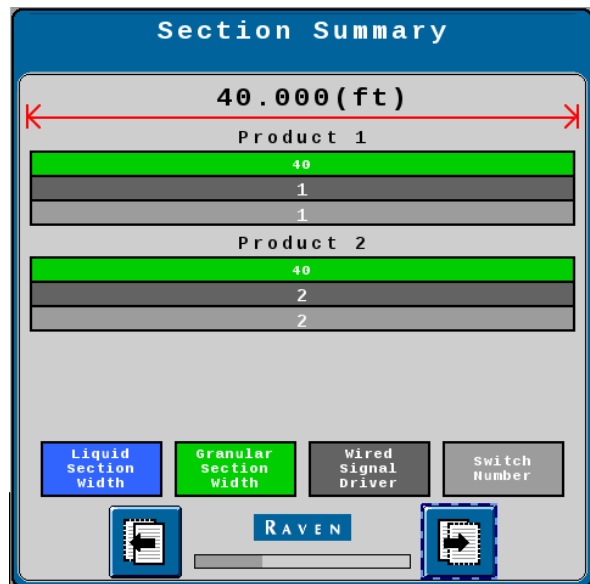

9. For our machines, Scales are not offered:

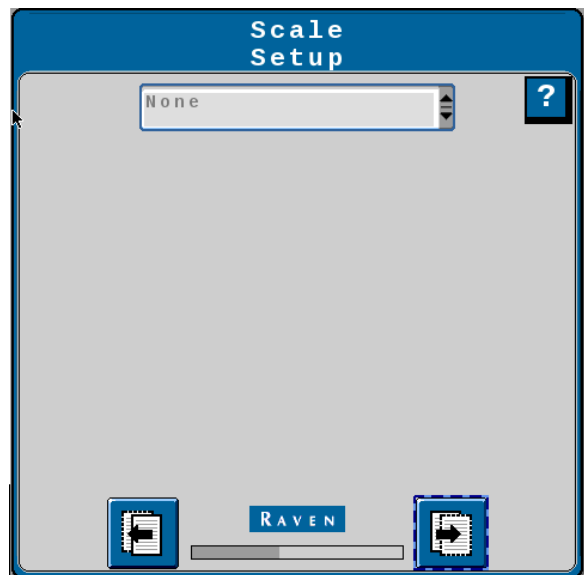

10. For our machines: Pressure Sensors are not offered:

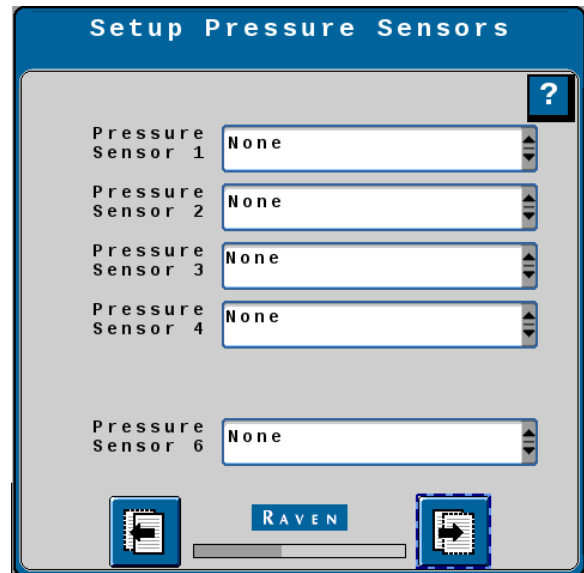

11. Enter "2" for Pulses per Revolution and set the limits as shown:

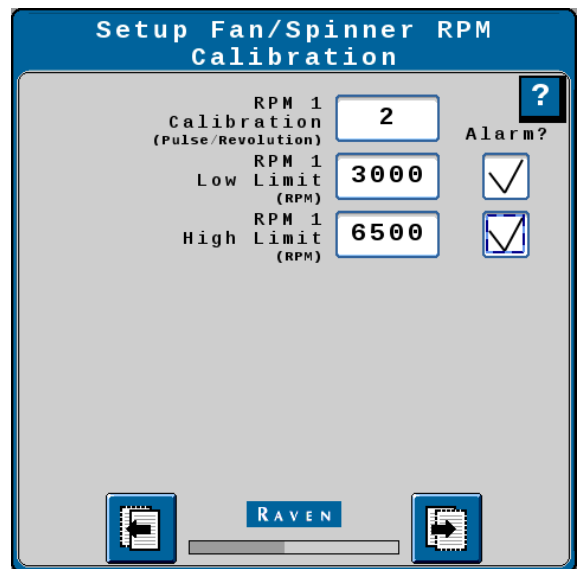

12. Be Sure that Both Products are selected for the RPM sensor 1:

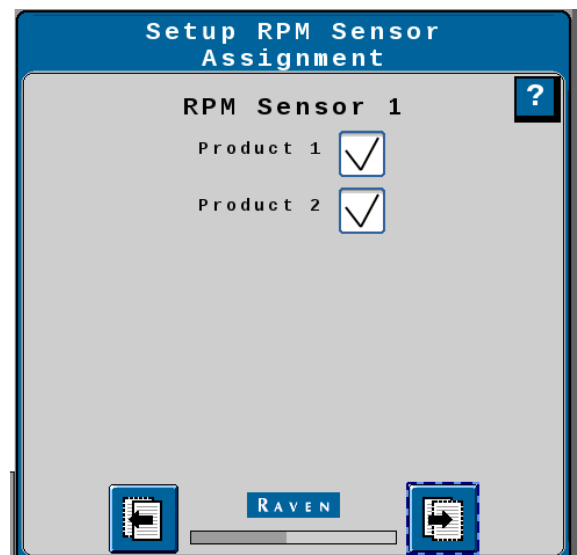

13. With Ground Drive, there is not a control valve:

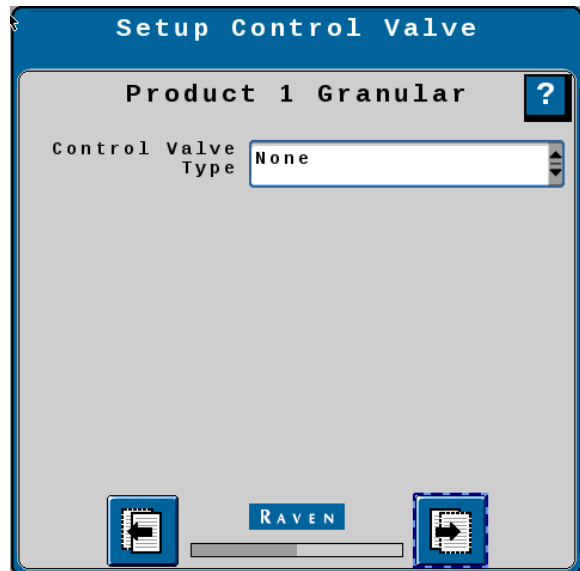

14. Product Density and Calibration weight can be entered here, however, if these values are now known, they can be entered in the Rate Sensor Setup Page. The meter shaft has 1 pulse per revolution:

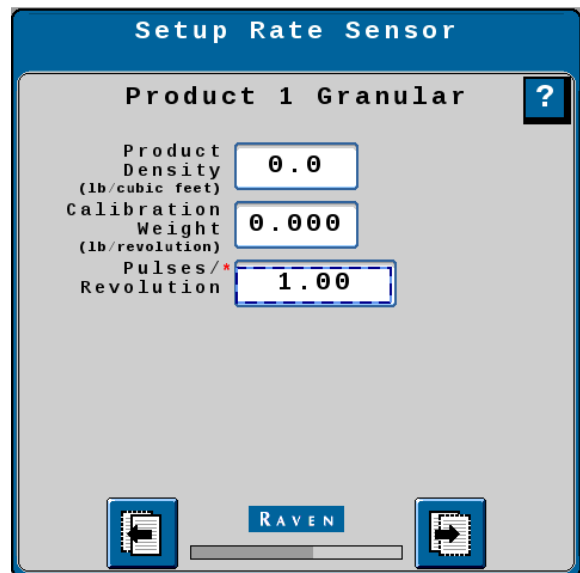

15. The tank capacity in lbs may vary based on product density, configure the bin levels for Product 1 as shown. Tank Levels can be entered in the Tank Fill Settings page.

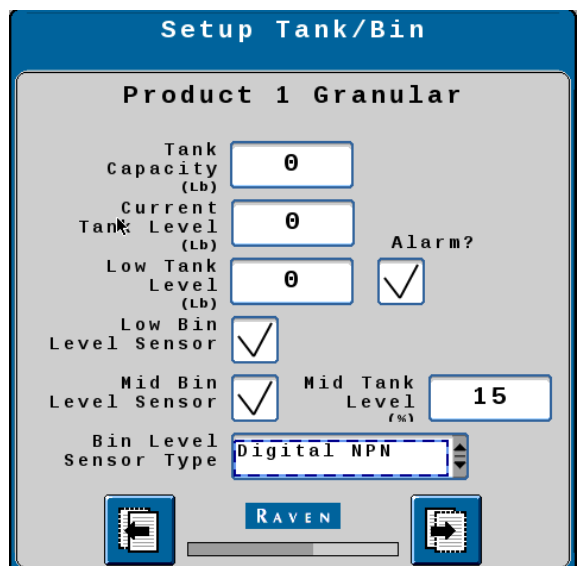

16. The preset values do not affect machine performance on a Ground Drive, enter a value.

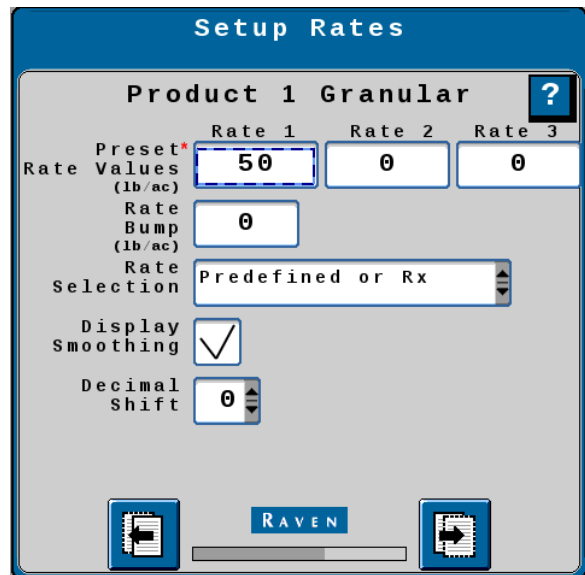

17. Set up Alarms as shown: The shaft sensor alarm is not used on this machine.

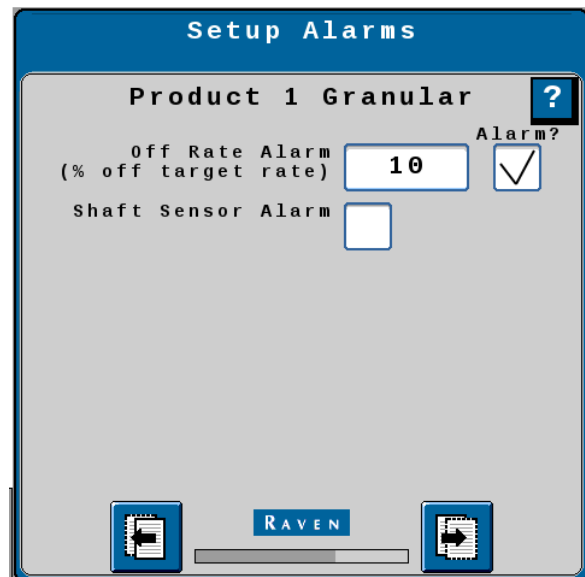

18. With Ground Drive, there is not a control valve:



19. Product Density and Calibration weight can be entered here, however, if these values are now known, they can be entered in the Rate Sensor Setup Page. The meter shaft has 1 pulse per revolution:

Setup Rate Sensor

Product 2 Granular ?

Product Density (lb/cubic feet)

Calibration Weight (lb/revolution)

Pulses/Revolution

RAVEN

20. The tank capacity is lbs may vary based on product density, configure the bin levels for Product 2 as shown:

Setup Tank/Bin

Product 2 Granular

Tank Capacity (lb)

Current Tank Level (lb)

Low Tank Level (lb) Alarm?

Low Bin Level Sensor

Mid Bin Level Sensor Mid Tank Level (%)

Bin Level Sensor Type

RAVEN

21. The preset values do not affect machine performance on a Ground Drive, enter a value.

Setup Rates

Product 2 Granular ?

	Rate 1	Rate 2	Rate 3
Preset* Rate Values (lb/ac)	<input type="text" value="50"/>	<input type="text" value="0"/>	<input type="text" value="0"/>
Rate Bump (lb/ac)	<input type="text" value="0"/>		
Rate Selection	<input type="text" value="Predefined or Rx"/>		
Display Smoothing	<input checked="" type="checkbox"/>		
Decimal Shift	<input type="text" value="0"/>		

RAVEN

22. Set up Alarms as shown: The shaft sensor alarm is not used on this machine.

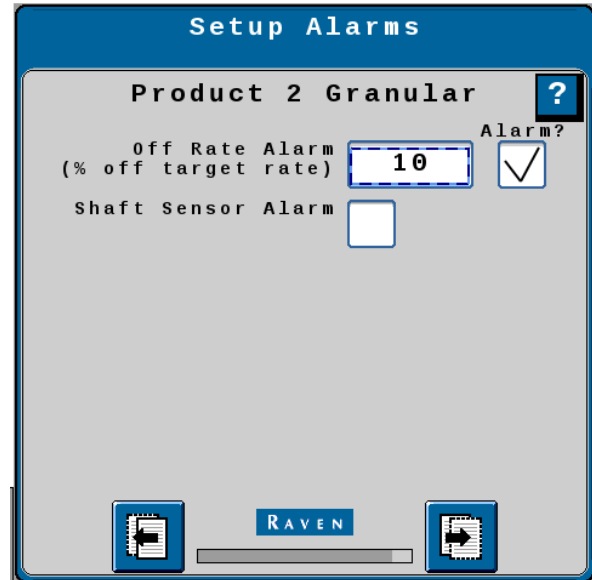

23. The summary screen for a Ground Drive Machine should look as shown.

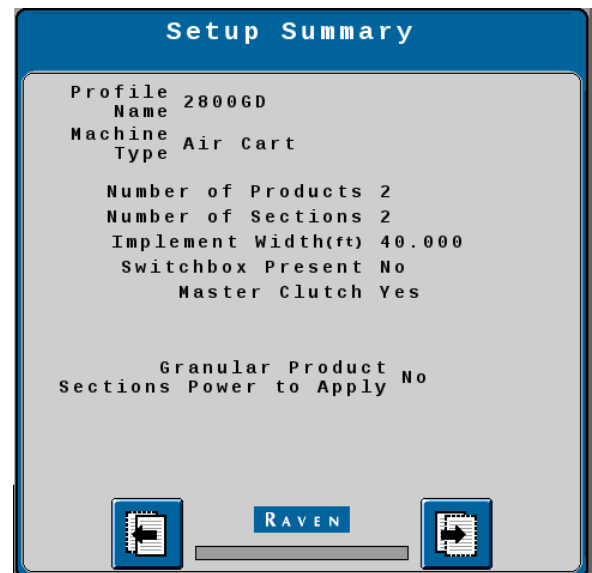

24. You will need to enter the calibration number you determined by the catch test. This will dispense product virtually on the screen and keep the bin levels accurate.



3.15.2 Profile Set Up (Hydraulic Drive)

Upon initial start up, if no profile is loaded you will be prompted to set one up. Follow these steps to set up a Hydraulic Drive Amity Air Cart

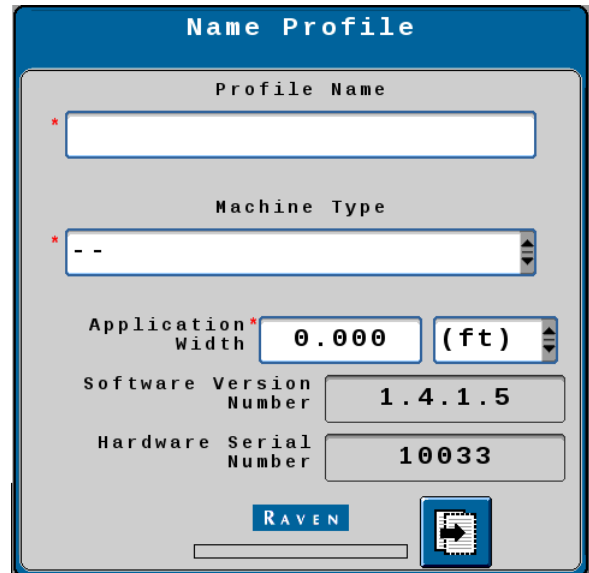

1. Enter Profile Name (Tank Size HYD) HYD = Hydraulic Drive
Machine Type – Air Cart
Toolbar Width – Note the width can be entered in feet or inches

Select Next (1).

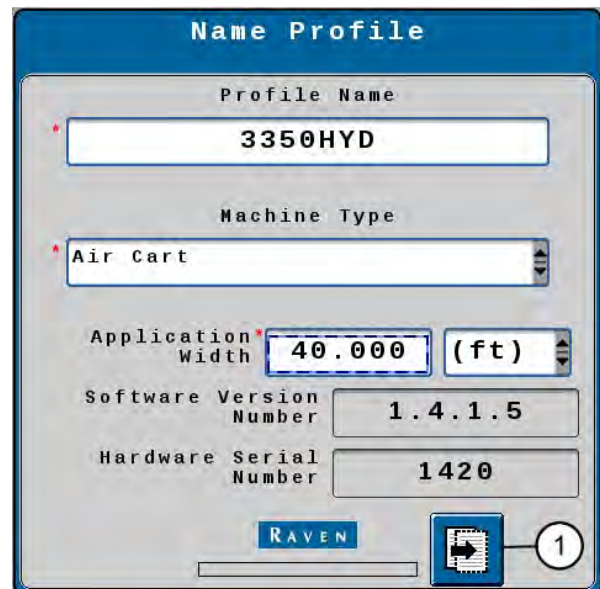

2. Enter Number of Products (Bins) 2 or 3
2800/3350 = 2 Products
3800/5250 = 3 Products

Select Next (1) to advance to the next screen after completely this step and each of the following steps. Select Return (2) to go back and edit a previous step.

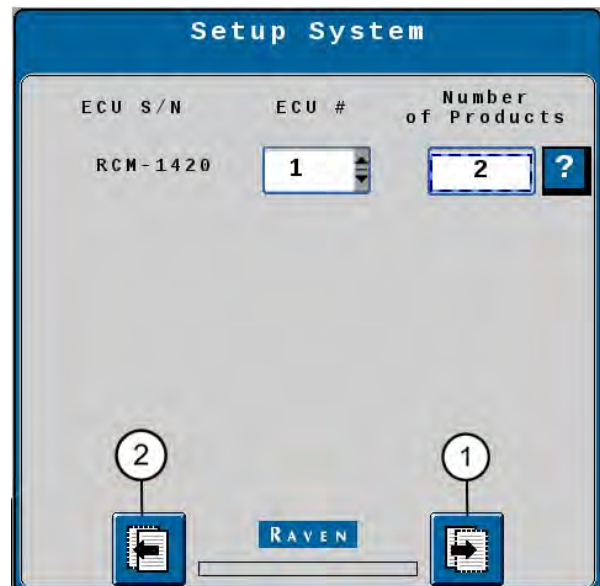

3. Select the Number of Fans on the Machine:
2 are available with the 3 Bin Cart only.

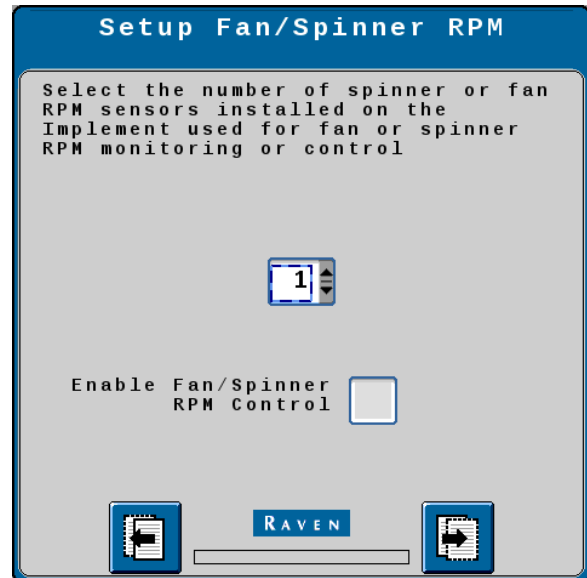

4. Select Product Type:

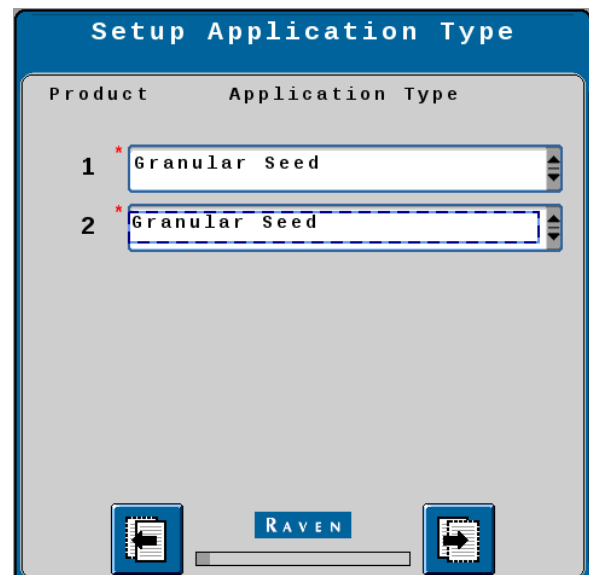

5. Select Application Mode for each product selected:

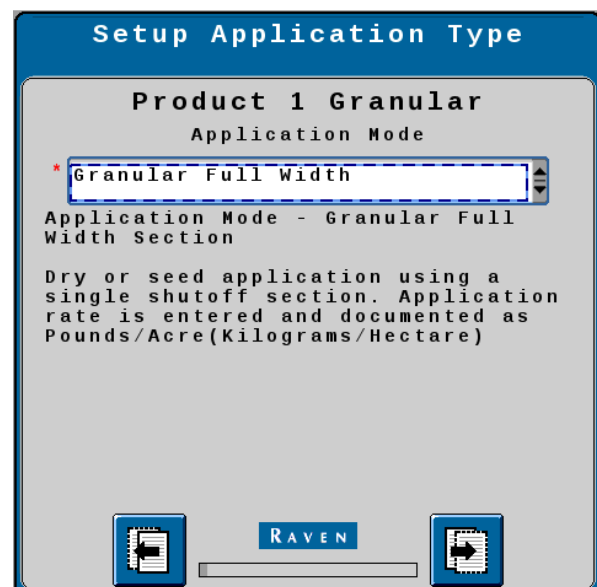

6. Ensure for Hydraulic Drive, Master Clutch is NOT selected.

Each product selected will have a section group
 For a 2 Bin Cart = 2 Section Groups
 For a 3 Bin Cart = 3 Section Groups

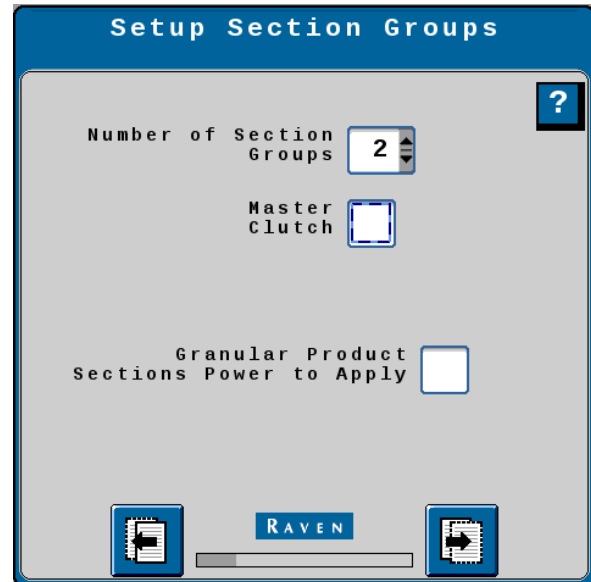

7. For our Machines, there are no Auxiliary Drivers available:

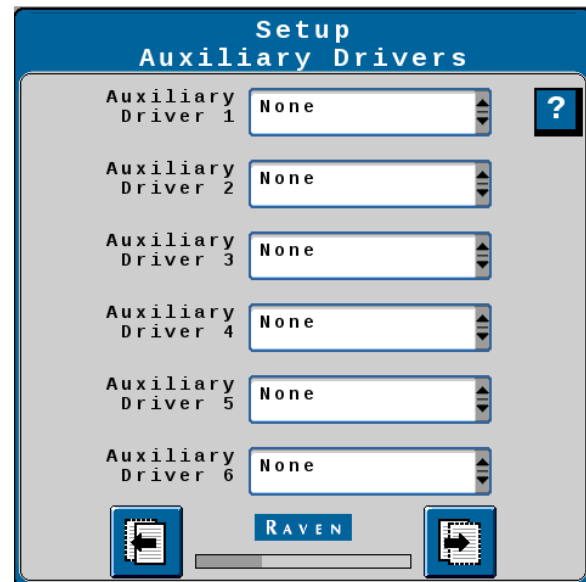

8. Review the Section Summary to ensure the widths and sections are correct:

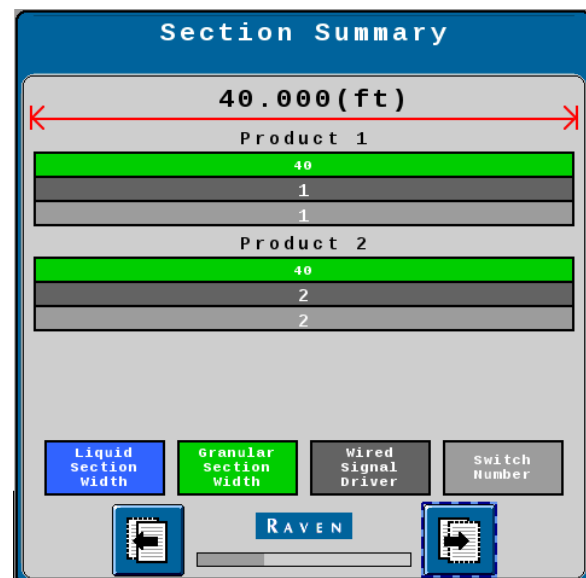

9. For our machines, Integrated Scales are not offered:

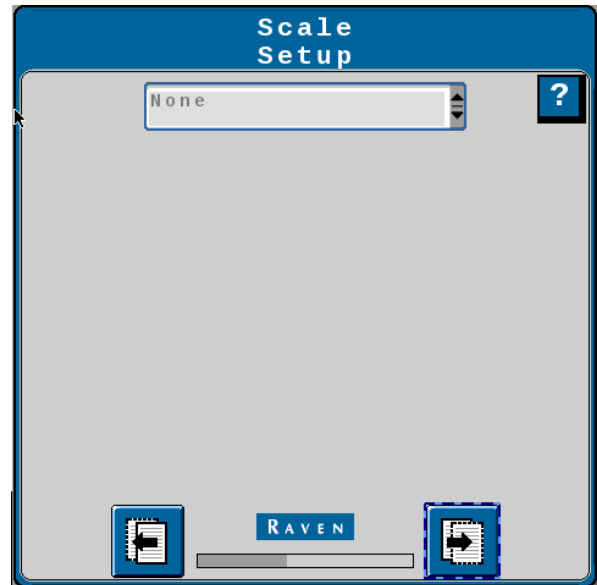

10. For our machines, Pressure Sensors are not offered:

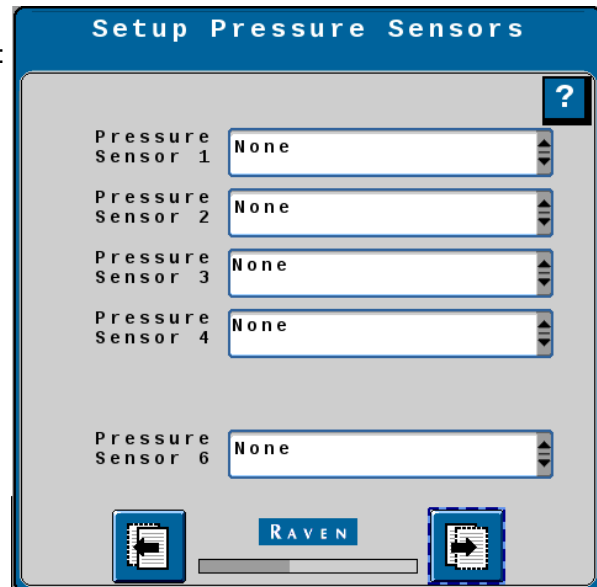

11. Enter "2" for Pulses per Revolution and set the limits as shown:

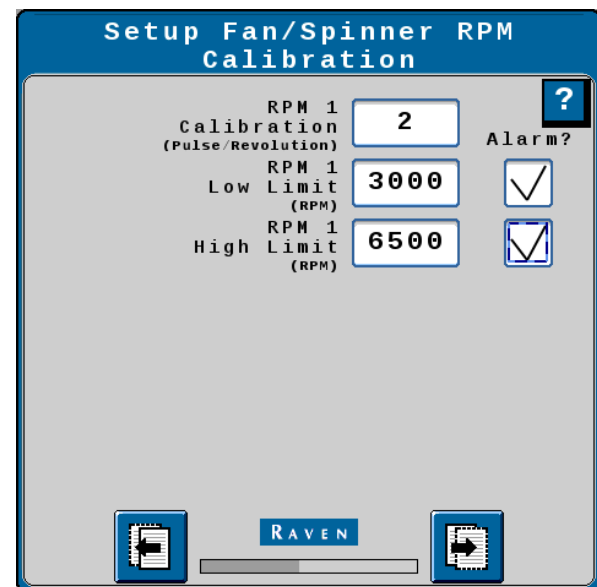

12. Be Sure that Both Products are selected for the RPM sensor 1: These are located on the Hydraulic motors

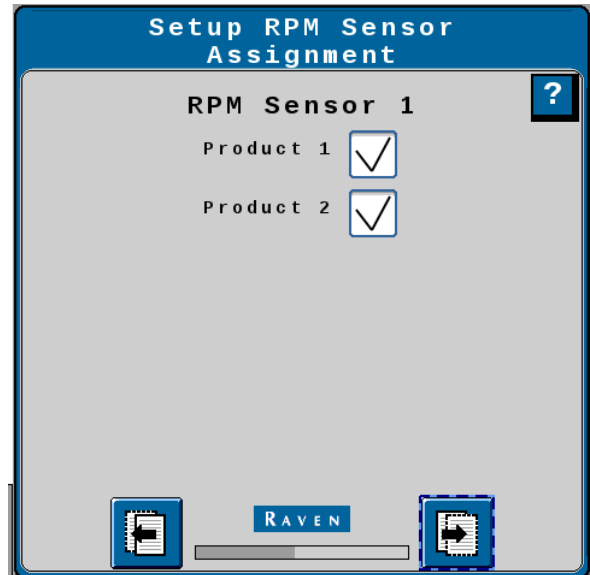

13. Setup Control valve parameters as noted:

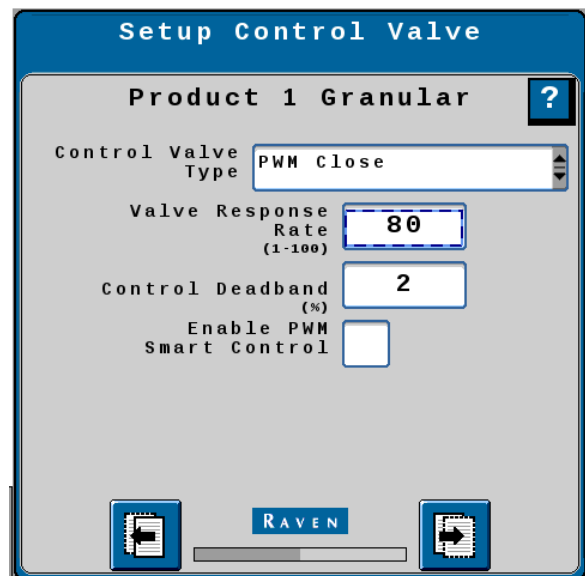

14. Setup PWM Parameters as noted:

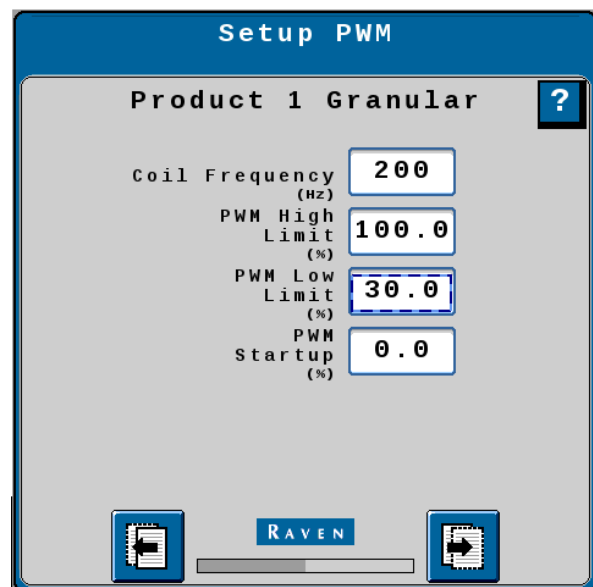

15. Product Density and Calibration weight can be entered here, however, if these values are not known, they can be entered in the Rate Sensor Setup Page. The hydraulic meter motor has 60 pulses/revolution:

Setup Rate Sensor

Product 1 Granular ?

Product Density (lb/cubic feet)

Calibration Weight (lb/revolution)

Pulses/Revolution

RAVEN

16. The tank capacity in lbs may vary based on product density, configure the bin levels for Product 1 as shown. Tank Levels can be entered in the Tank Fill Settings page.

Setup Tank/Bin

Product 1 Granular

Tank Capacity (Lb)

Current Tank Level (Lb)

Low Tank Level (Lb) Alarm?

Low Bin Level Sensor

Mid Bin Level Sensor Mid Tank Level (%)

Bin Level Sensor Type

RAVEN

17. The preset values do not affect machine performance on a Hydraulic Drive, Enter Values you wish. These are also editable after Profile set up is complete

Setup Rates

Product 1 Granular ?

	Rate 1	Rate 2	Rate 3
Preset* Rate Values (lb/ac)	<input type="text" value="50"/>	<input type="text" value="0"/>	<input type="text" value="0"/>

Rate Bump (lb/ac)

Rate Selection

Display Smoothing

Decimal Shift

RAVEN

18. Set up Alarms as shown: The shaft sensor alarm is not used on this machine.

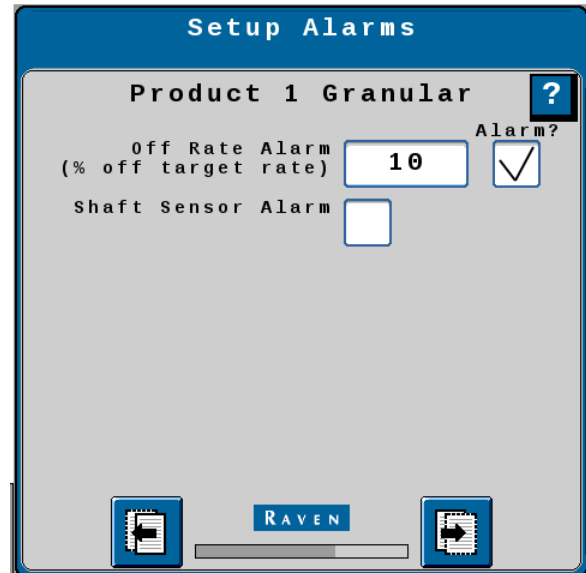

19. Setup Control Valve parameters as noted:

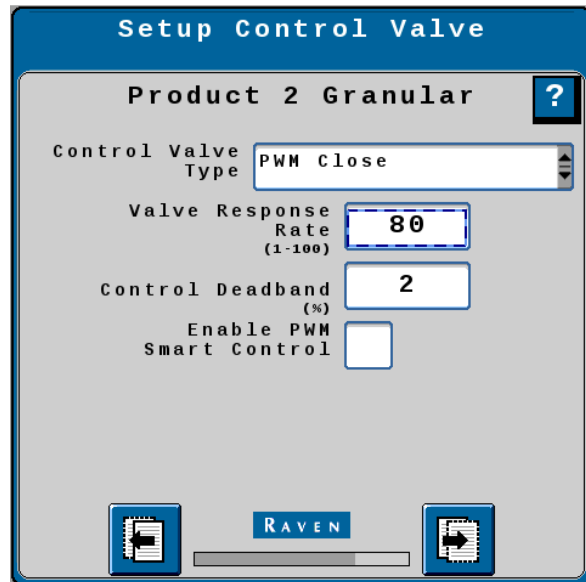

20. Setup PWM Parameters as noted:

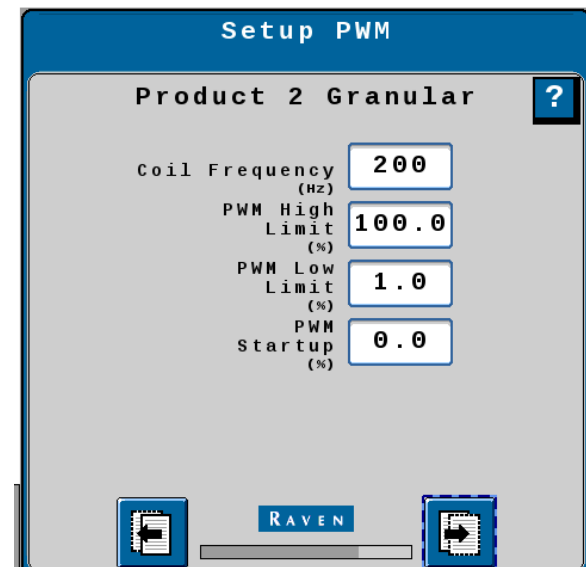

21. Product Density and Calibration weight can be entered here, however, if these values are not known, they can be entered in the Rate Sensor Setup Page. The hydraulic meter motor has 60 pulses/revolution:

Setup Rate Sensor

Product 2 Granular ?

Product Density (lb/cubic feet)

Calibration Weight (lb/revolution)

Pulses/Revolution

RAVEN

22. The tank capacity in lbs may vary based on product density, configure the bin levels for Product 2 as shown. Tank Levels can be entered in the Tank Fill Settings page.

Setup Tank/Bin

Product 2 Granular

Tank Capacity (Lb)

Current Tank Level (Lb)

Low Tank Level (Lb) Alarm?

Low Bin Level Sensor

Mid Bin Level Sensor Mid Tank Level (Lb)

Bin Level Sensor Type

RAVEN

23. The preset values do not affect machine performance on a Hydraulic Drive, Enter Values you wish.

Setup Rates

Product 2 Granular ?

	Rate 1	Rate 2	Rate 3
Preset* Rate Values (lb/ac)	<input type="text" value="50"/>	<input type="text" value="0"/>	<input type="text" value="0"/>
Rate Bump (lb/ac)	<input type="text" value="0"/>		
Rate Selection	<input type="text" value="Predefined or Rx"/>		
Display Smoothing	<input checked="" type="checkbox"/>		
Decimal Shift	<input type="text" value="0"/>		

RAVEN

24. Set up Alarms as shown: The shaft sensor alarm is not used on this machine.

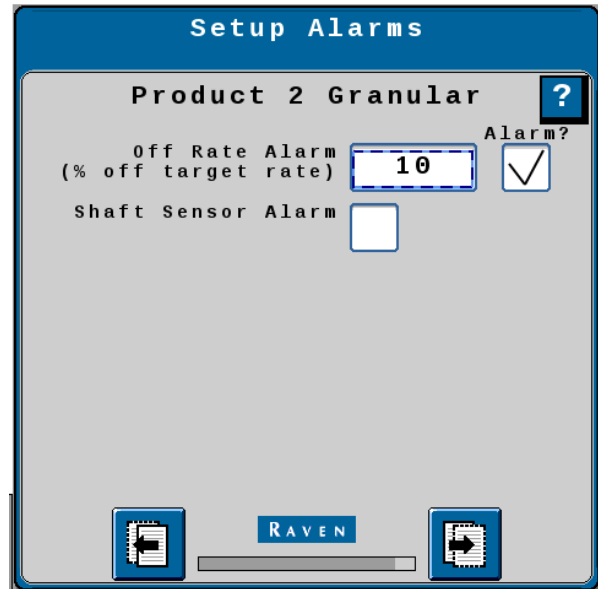

25. The summary screen for a Hydraulic Drive 2 Bin Machine should look as shown.

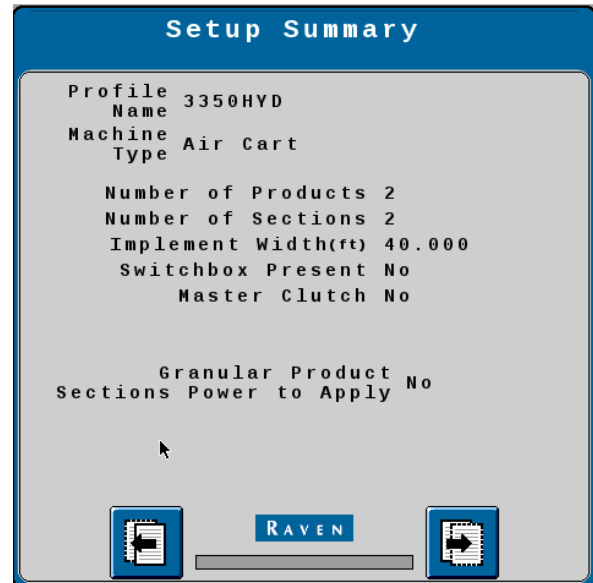

26. You will need to enter the calibration number you determined by the catch test. This will dispense product virtually on the screen and keep the bin levels accurate.

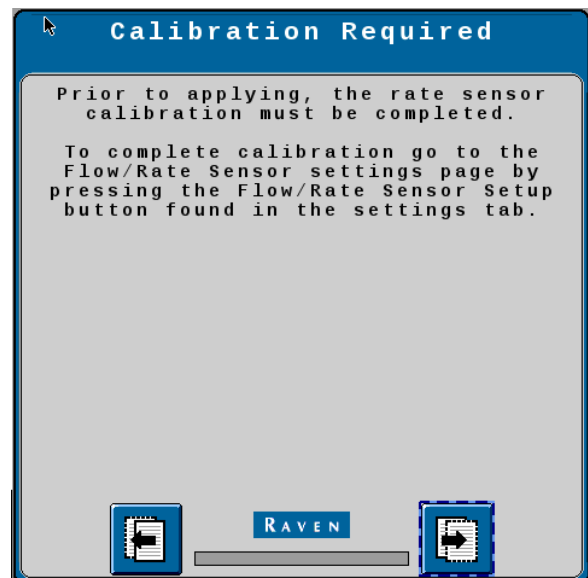

3.15.3 Master switch operation

The cart control system requires a master work switch.



The master work switch is an icon  located on the lower portion of most screens on the terminal. The automatic work switch is a sensor, located on toolbar.

When the system is configured for automatic work switch operation, lifting the machine automatically turns off the meters and NH3 system. Lowering the machine automatically turns on the meters and NH3 system. In this mode the manual work switch can be used on the terminal to turn the meters and NH3 system off.

Disable the automatic height switch if desired configure the system to operate the meters and NH3 system in manual only.

3.15.4 Enabling Automatic Height Switch

Procedure

1. From the main (home) work screen, select  to change the work switch operation mode.
2. Select the box on the bottom of the screen to enable the Height Switch.
3. Return to Home and there will be an arrow next to the master icon to symbolize the state of the implement. 

3.15.5 Manual work switch operation

To change the state of the master switch, use the foot switch that is supplied with the cart. This should be placed in the cab within reach of the operator.

3.15.6 Setting the automatic height switch operation



Procedure

1. Raise the seeding system.
2. Depress the foot-pedal to change the state of the master switch 
3. Move the machine forward in the field.
4. Lower the seeding system.

The following conditions must be met for the clutch to engage or for the hydraulic motors to turn:

- The ground speed must be above the minimum speed setting.
- The master switch icon must be green.
- The Seeder up/down will indicate down and green

3.15.7 Customizing Product Tabs

1. Select Settings: 
2. Select System Settings tab: 
3. Select Display Setup Menu:
4. Each Product is configurable to display what you wish.



There are select tabs that are not editable that are required to be displayed All "Press to Select" readouts are editable and can display a variety of outputs

Note: "RPM 1" is the fan speed output

3.15.8 Setting Test Speed

1. From the home screen press the speed read out
2. A pop up will appear with a field to enter a value.
3. Enter the value you desire

3.15.9 Refilling Product Bins

1. Select Settings: 
2. Select System Settings tab: 
3. Select Tank Fill Settings
 - From this page you can edit the Tank Fill Capacity, Current Tank Level and Alarm settings•
 - Enter the Tank Fill Capacity by multiplying tank size (bu) by Product Density (lbs/bu)
 - Enter the current tank level based on the amount of product in the bin (lbs)

OR

1. From the Home Screen Select the desired product to fill
2. Select the bin icon on the bottom of the page
 - From this page you can edit the Tank Fill Capacity, Current Tank Level
 - Enter the Tank Fill Capacity by multiplying tank size (bu) by Product Density (lbs/bu)
 - Enter the current tank level based on the amount of product in the bin (lbs)

DO NOT CHANGE THE DENSITY AFTER YOU HAVE CALIBRATED. THE CALIBRATION NUMBER WILL BE CHANGED

4. Maintenance

4.1 Lubrication points	99
4.1.1 Lubrication and maintenance chart	99
4.1.2 Lubrication fitting locations	99
4.2 Hydraulic motor maintenance	101
4.3 Gear box maintenance	102
4.3.1 Replacing the gearbox coupler shear pin	102
4.4 Wheel bearing maintenance	103
4.5 Tires and wheels	104
4.6 Storing the air cart	105
4.7 Connectors	106
4.7.1 ECU signal connectors	106
4.7.2 ISO-Bus connector	107
4.7.3 CAN terminator connector	107
4.7.4 ECU power contacts	108
4.7.5 Motor control connectors	108
4.7.6 Motor speed (tach) connectors	108
4.7.7 Low-bin level sensor connectors	109
4.7.8 Meter box sensor connectors	109
4.7.9 Ground speed sensor connectors	110
4.7.10 Fan sensor connectors	110
4.7.11 Anhydrous ammonia / liquid control connector	111

4.1 Lubrication points

See the machine specification for the correct lubricant.

Do not let grease build up on or around parts, especially when operating in sandy soil.

Make sure to clean the lubrication fittings fully before connecting the grease gun.

Watch each lubrication point while lubricating to make sure the lubricant applies correctly.

Check for any loose, missing, or worn parts when lubricating the machine.

Check the lubrication service schedule for the correct lubrication interval.

4.1.1 Lubrication and maintenance chart

Interval	Procedure
Daily	Check the tire pressure
50 hours	Lubricate the meter box lubrication fittings
	Lubricate the driveline and steering lubrication fittings
Yearly	Lubricate the Hinge point lubrication fittings
	Check the wheel bearings
Every three years	Service the wheel bearings

4.1.2 Lubrication fitting locations

Hinge points

Find five lubrication fittings (1) on the hinge points.

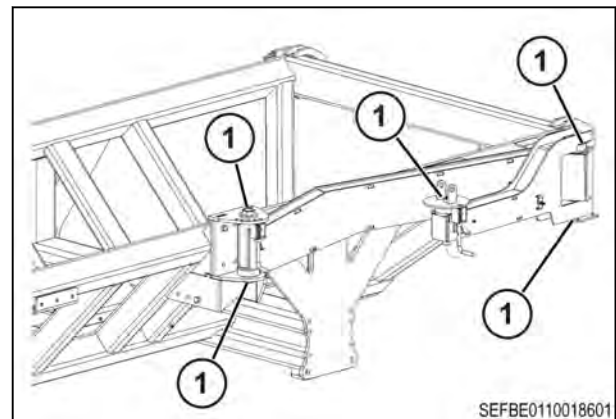

Fig. 1

Meter box

Find three lubrication fittings (1) on the meter box.

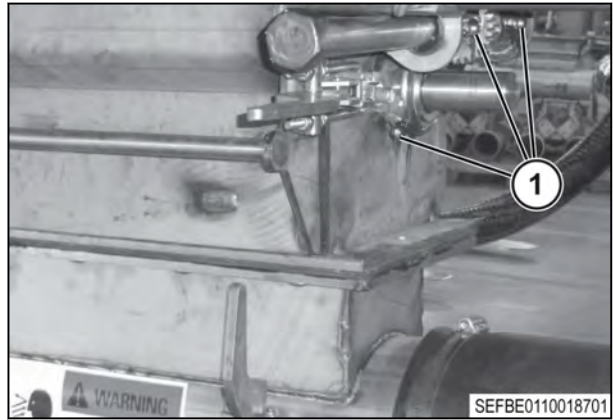

Fig. 2

Driveline and steering

Find three lubrication fittings (1) on the each side of each axle.

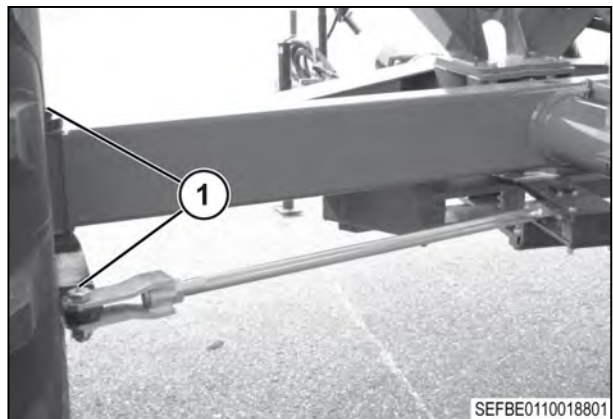

Fig. 3

4.2 Hydraulic motor maintenance

WARNING: Park the machine on a solid, level surface. Lower and stop the machine, set the park brake, turn off the tractor engine and take the key with you before doing any maintenance on the machine.

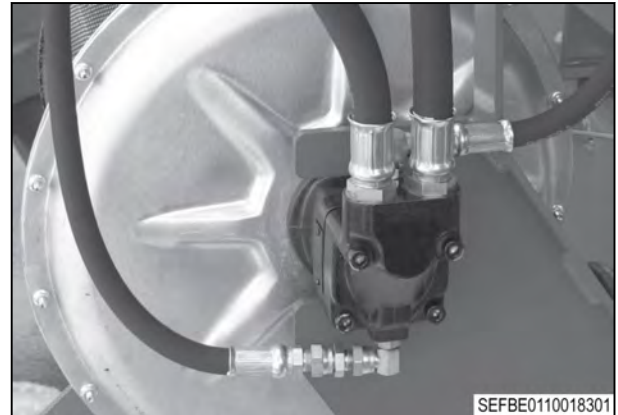

Fig. 4

The hydraulic motor can only be damaged by heat or foreign material.

Keep the tractor hydraulic oil and filter serviced regularly to give long life from the hydraulic components.

4.3 Gear box maintenance

WARNING: Park the machine on a solid, level surface. Lower and stop the machine, set the park brake, turn off the tractor engine and take the key with you before doing any maintenance on the machine.

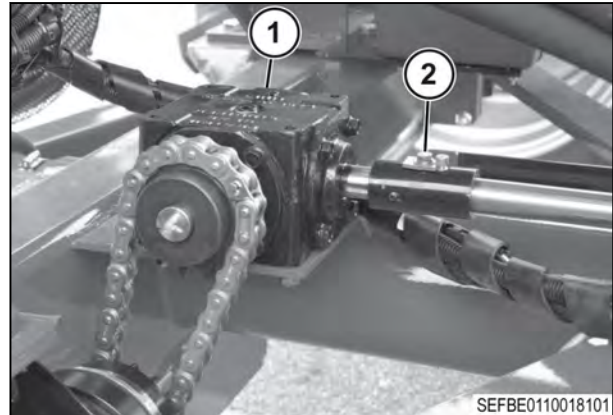

Fig. 5

The gearbox (1) is filled at the factory and requires no maintenance.

Service is required only if leaks become visible.

If a leak becomes visible, repair the leak and fill the gearbox half full with 85W-90 oil.

The driveline components are protected by a shear pin (2) on the gearbox coupler. If the shear pin fails, determine the reason for the failure and install a new shear pin. See the information for replacing the shear pin.

4.3.1 Replacing the gearbox coupler shear pin

Procedure

1. Park the machine on a solid, level surface.
2. Stop the tractor engine, apply the park brake, and take the key with you.
3. Loosen the capscrew (1) on the locking tab and rotate the tab out of the machined groove in the shear pin (2).
4. Remove any broken shear pin pieces and line up the holes in the coupler with the hole in the shaft.
5. Install a new shear pin.
6. Rotate the lock tab into the machined groove.
7. Tighten the capscrew on the locking tab.

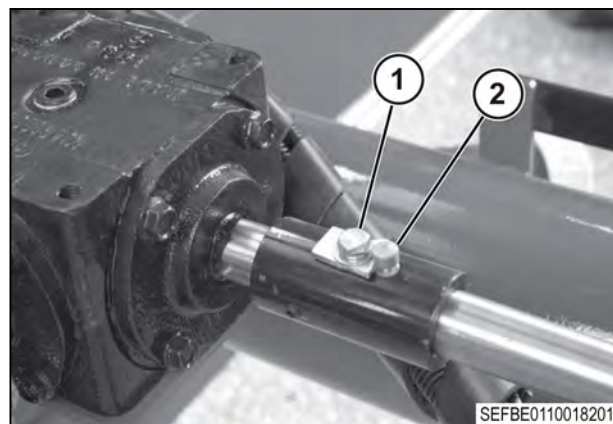

Fig. 6

4.4 Wheel bearing maintenance

Check the wheel bearings once per year, adjust if necessary.

Service the bearings at least every three years.

4.5 Tires and wheels

Specification	Two bin	Three bin
Tire size	18.4 X 26.0 10 ply	620/70 R42 - 525
	23.1 X 26.0 10 ply	800/70 R38 - 380
Load index		166 A8
Maximum pressure	18.4 X 26.0 10 ply 138 kPa kPa (20 psi)	103 kPa (15 psi)
Lug nut torque	325 Nm (240 lbf ft)	678 Nm (500 lbf ft)

Put oil on the lug nuts before tightening and check the torque after ten hours of operation.

WARNING:

The maximum speed of the air cart is 32 km/hr (20 mph)

4.6 Storing the air cart

Procedure

1. Park the machine on a solid, level surface.
2. Fully open the seed meters.
3. Open the cleanout doors on the bottom of the air tube.
4. Clean all material out of the tanks.
5. Use water to completely clean any compartment used for fertilizer.
6. Completely clean fertilizer and dirt from the cup area.
7. Clean the inside of the seed meter door.
8. Clean all material out of the auger and leave the auger slide open.
9. Lubricate all of the chains.
10. Lubricate all lubrication fittings.
11. Check the gearbox for visible leaks. See the information for gearbox maintenance.
12. Release the latch on the tank covers to remove pressure on the cover gaskets.

5. Troubleshooting

5.1 Troubleshooting 115

5.1 Troubleshooting

Problem	Causes	Correction
The seed cups do not engage.	Product turned off at the terminal.	Turn on the product from terminal.
	Below the minimum speed for the machine.	Increase the machine speed over the minimum speed setting.
The seed flows without the cups turning. (A small amount of seed flows is normal.)	Rubber deflector is not down tightly on the flute.	Lower the deflector.
	Rubber wiper on seed cup door damaged or not up tightly against the flute.	Raise the door. Replace damaged rubber wipers.
	Product plugs the air delivery system.	Increase the blower speed.
Too many seeds crack.	The air stream velocity is too fast.	Reduce the blower speed or adjust the blower baffle on the dual air stream machines.
The seed boots plug.	Turning corners too tightly with boots in the ground.	Always raise the ground opener before making a sharp turn.
	Ground openers remain in the ground when going in reverse.	Always raise the ground opener before going in reverse.
The machine does not distribute product evenly.	A plugged one inch hose.	Change the route of the one inch hoses or cut the one inch hoses to straighten the hoses. Clear any obstruction in hoses or boots.
	The splitter is not calibrated.	Calibrate the splitter the same on each side.
	The pressure tube is in the wrong air stream (for dual chute machines only).	Switch to the air stream being used.
The machine does not move product at an even rate.	There is a loss of tank pressure.	Check the tank covers for leaks. Inspect and replace faulty gaskets.
Oil shows on the seed lines.	There is a shaft seal failure on a hydraulic motor.	Replace the seal. IMPORTANT: Do not disassemble the hydraulic motor. The shaft seal is an external replacement item.
A hydraulic motor goes too slowly.	The terminal is set to the wrong blower speed setting. See the information for the terminal.	See the information for the terminal.

Problem	Causes	Correction
	The tractor is not putting out enough oil.	Have the tractor dealer inspect the tractor hydraulics.
	There are bad couplers.	Check the couplers on the tractor and the hoses. Try different couplers.
The machine hydraulic lines cannot be connected to the tractor.	There is back pressure on the system is preventing the coupler from releasing.	Press the relief button on the control block located near the fan on the front of the machine.

6. Specifications

6.1 Specifications	119
6.1.1 Specifications - two-bin model	119
6.1.2 Specifications - three-bin model	119
6.1.3 Conversion factors	120
6.1.4 Formulas	121
6.2 Approximate tank fill percentages	122
6.3 Maximum transport speed	123

6.1 Specifications

6.1.1 Specifications - two-bin model

Feature	Two-bin model 9.9 cu m (280 bushel)	Two-bin model 11.8 cu m (335 bushel)
Hopper capacity	9.9 cu m (5.9 cu m rear, 4 cu m front) (280 bushel) ((168 bushel) rear, (112 bushel) front)	11.8 cu m (7 cu m rear, 4.8 cu m front) (335 bushel) ((200 bushel) rear, (135 bushel) front)
Blower drive	Hydraulic drive	Hydraulic drive
Meter drive	Ground (optional hydraulic drive)	Ground (optional hydraulic drive)
Wheel spacing	36.6 m (120 in) front 45.7 cm (150 in) rear (120 in) rear, optional	36.6 m (120 in) front 45.7 cm (150 in) rear (120 in) rear, optional
Tire size	23.1 x 26R1 - standard 58.7 cm x 60 cm 18.4 x 26 - optional 46.7 cm x 60 cm	23.1 x 26R1 - standard 58.7 cm x 60 cm 18.4 x 26 - optional 46.7 cm x 60 cm
Fill/unload auger poly flighting	20.3 cm x 5.49 m (8 in x 18 ft)	25.4 cm x 6.4 m (10 in x 21 ft)
Total height	3.84 m (12 ft - 7 in)	4.09 m (13 ft - 5 in)
Total length	8.23 m (27 ft - 0 in)	8.23 m (27 ft - 0 in)
Maximum width	4.39 m (14 ft - 5 in)	4.39 m (14 ft - 5 in)
Fill height	3.35 m (11 ft - 0 in)	3.60 m (11 ft - 10 in)
Minimum ground clearance	48.3 cm (19 in)	48.3 cm (19 in)
Empty weight	3810 kg (8400lb)	3900 kg (8600lb)

6.1.2 Specifications - three-bin model

Feature	Three-bin model 13.4 cu m (380 bushel)	Three-bin model 18.5 cu m (525 bushel)
Hopper capacity	13.4 cu m (4.5 cu m front, 5.6 cu m center, 3.3 cu m rear) (380 bushel) ((128 bushel) front, (158 bushel) center, (94 bushel) rear)	18.5 cu m (6.2 cu m front, 7.9 cu m center, 4.4 cu m rear) (525 bushel) ((175 bushel) front, (225 bushel) center, (125 bushel) rear)
Blower drive	Hydraulic drive	Hydraulic drive
Meter drive	Hydraulic drive	Hydraulic drive
Wheel spacing	361 cm (118 in) on centers	Inside duals 300 cm (118 in) on centers Outside duals 462 cm (182 in) on centers

Feature	Three-bin model 13.4 cu m (380 bushel)	Three-bin model 18.5 cu m (525 bushel)
Tire size	800/70R38 singles	620/70R42 duals
Fill/unload auger cupped steel flighting (poly flighting optional)	25.4 cm x 7.6 m (10 in x 25 ft)	25.4 cm x 7.6 m (10 in x 25 ft)
Total height	4.26 m (14 ft - 0 in)	4.67 m (15 ft - 4 in)
Total length	6.94 m (29 ft - 4 in)	8.94 m (29 ft - 4 in)
Maximum width	5.33 m (17 ft - 4 in)	5.33 m (17 ft - 4 in)
Fill height	3.07 m (10 ft - 10 in)	3.71 m (12 ft - 2 in)
Minimum ground clearance	45.72 cm (18 in)	45.72 cm (18 in)
Empty weight	6124 kg (13 500 lb)	7144 kg (15 750 lb)

6.1.3 Conversion factors

Area	
One hectare	2.47 acres
One acre	0.404 hectare
One acre	43 560 square feet

Distance	
One inch	2.54 centimeters
One foot	0.3048 meters
One mile	1.609347 kilometers

Weight	
One pound	0.45359 kilogram
One pound	16 ounces
One kilogram	35.3 ounces
One ounce	0.028 kilogram

Speed	
One mile per hour	1.609 kilometers per hour

Volume	
One bushel	1.2445 cubic feet
One bushel	0.0352 cubic meters
One bushel	9.31 gallons

Pressure	
1 pound per square inch	6.8948 kPa

Flow	
One gallon per minute	3.785 liters per minute

6.1.4 Formulas

$$\text{Rate (kg/min)} = \frac{\text{width (m)} \times \text{speed (km/hr)} \times \text{field rate (kg/hectare)}}{600}$$

$$\text{Rate (lbs/min)} = \frac{\text{width (ft)} \times \text{speed (mph)} \times \text{field rate (lbs/acre)}}{495}$$

$$\text{Performance (ha/hr)} = \frac{\text{width (m)} \times \text{speed (km/hr)}}{10}$$

$$\text{Performance (acres/hr)} = \frac{\text{width (ft)} \times \text{speed (mph)}}{8.25}$$

6.2 Approximate tank fill percentages

Approximate tank fill percentages								
Ladder rung (from the top)	Two-bin 9.9 cu m (280 bushel)	Two-bin 11.8 cu m (335 bushel)	Three-bin 13.4 cu m (380 bushel)			Three-bin 18.5 cu m (525 bushel)		
	Front and rear	Front and rear	Front	Middle	Rear	Front	Middle	Rear
1st	90%	85%	99%	99%	99%	99%	99%	99%
2nd	75%	60%	81%	84%	79%	85%	90%	85%
3rd	45%	35%	52%	51%	51%	65%	65%	65%
4th	15%	15%	25%	21%	25%	45%	40%	45%
5th	5%	5%	9%	7%	11%	20%	15%	20%
6th	does not apply	does not apply	does not apply	does not apply	does not apply	5%	5%	5%

6.3 Maximum transport speed

Maximum speed:

30 km/h (20 mph)

Index

A

accumulated weight on the virtual terminal	
entering	70
advanced setup	94
agricultural chemicals	15
air cart	43
air cart to drill hydraulic coupler	57
air cart to tractor hydraulic couplers	57
alarm and indicator icons	85
anhydrous ammonia / liquid control connector	111
application rate on a ground drive system	
setting	66
approximate tank fill percentages	122
auger	
cleaning out	55
auger to load products	
using	53
auger to unload products	
using	55
automatic work switch operation	
setting	92

B

barley rate chart	74
bin level sensor	83
blower	60
blower speed	60
blower speed sensor	82

C

calibrating a meter	
preparing	68
can terminator connector	107
canola rate chart	76
cart electronic control unit (ECU) sensor channel	
advanced screen	
changing	
metering rolls - ground drive system	63
metering rolls - hydraulic system	63
cleaning out	
auger	55
confirmation screen	86
conversion factors	120

D

Raven electronic control unit	82
Raven system hardware	82
Raven system overview	82
deflector block	64
disposal of waste	39
dry product/bin settings	92

E

ecu power contacts	108
--------------------	-----

ecu signal connectors	106
entering	
accumulated weight on the virtual terminal	70
exhaust warning	14
external work switch operation mode	
selecting	92

F

fan sensor connectors	110
fertilizer rate chart - 96 kg per cubic meter (60 lb per cubic foot)	72
fire prevention and first aid	19
flying debris	15
formulas	121

G

gear box maintenance	102
general maintenance information	18
ground drive	56
ground speed sensor	84
ground speed sensor connectors	110

H

high pressure leaks	20
hydraulic drive	59
hydraulic motor maintenance	101
hydraulic systems	57

I

informational messages	9
intended use	39
Introduction	39
iso-bus connector	107

L

ladder and railings - three-bin model	51
ladder and railings - two-bin model	51
low-bin level sensor connectors	109
lubrication	
lubrication points	99
lubrication and maintenance chart	99
lubrication fitting locations	99
lubrication points	
lubrication	99

M

machine identification	41
main (home) screen	87
major components	44
manual work switch operation	92
manually setting	
motor cal value for a variable rate system	71

marker lamps	22	soybean rate chart	78
maximum speed	123	specifications - three-bin model	119
meter		specifications - two-bin model	119
priming	69	storing the air cart	105
meter adjustments	64	system set up	90
meter box flow sensor	83	system settings screen	90
meter box sensor connectors	109		
meter door and cleanout door latches	65	T	
meter door tray	65	taking	
meter roll options	64	product sample for calibration	70
meter shaft speed sensor (ground drive)	83	tire safety	21
meter shaft speed sensor (hydraulic drive)	84	tires and wheels	104
metering rolls - ground drive system		transport	
changing	63	maximum speed	123
metering rolls - hydraulic system		travel on public roads	16
changing	63	troubleshooting	115
motor cal value for a variable rate system			
manually setting	71	U	
motor control connectors	108	units of measurement	39
motor speed (tach) connectors	108	using	
		auger to load products	53
O		auger to unload products	55
operator manual storage	46, 47		
		V	
P		virtual terminal	82
personal protective equipment	13	virtual terminal - cart control system	85
prepare for operation	12		
preparing		W	
calibrating a meter	68	wheat rate chart	80
priming		wheel bearing maintenance	103
meter	69	word to the operator	10
product bin alarms	89	work switch operation	91
product bin lids	52		
product meter adjustment	62		
product sample for calibration			
taking	70		
proper disposal of waste	39		
R			
replacement parts	21, 39		
replacing the gearbox coupler shear pin	102		
S			
safety alert symbol	9		
safety general information	12		
safety messages	9		
safety sign location	23		
safety signs	9		
seat instructions	13		
selecting			
external work switch operation mode	92		
selecting air stream	61		
sensor types	96		
serial number description	41		
serial number plate	41		
setting			
application rate on a ground drive system	66		
automatic work switch operation	92		
shield and guards	14		
shims	64		

