

# **AIR TILL DRILL**

## **ASSEMBLY, OPERATORS & PARTS MANUAL**

### **5015/6015 UNIT**

# PERSONAL SAFETY IS IMPORTANT!

ALL PERSONNEL INVOLVED WITH THE ASSEMBLY AND/OR OPERATION OF THIS EQUIPMENT MUST BE INFORMED OF PROPER SAFETY PROCEDURES. OPERATOR'S/ ASSEMBLY MANUALS PROVIDE THE NECESSARY INFORMATION. IF THE MANUAL IS LOST FOR A PARTICULAR IMPLEMENT, ORDER A REPLACEMENT AT ONCE. OPERATOR'S AND ASSEMBLY MANUALS ARE AVAILABLE AT NO CHARGE UPON REQUEST.

This Safety Alert symbol means **ATTENTION!** **BECOME ALERT YOUR SAFETY IS INVOLVED!**



The Safety Alert symbol identifies important safety messages on your Wil-Rich DOT Disk and in this manual. When you see this symbol, be alert to the possibility of personal injury or death. Follow the instructions in the safety message.

Why is SAFETY important to you?

## 3 Big Reasons

**Accidents Disable and Kill**  
**Accidents Cost**  
**Accidents Can Be Avoided**

### SIGNAL WORDS:

Note the use of the signal words **DANGER**, **WARNING** and **CAUTION** with the safety messages. The appropriate signal word for each message has been selected using the following guidelines:

### DANGER

An immediate and specific hazard which **WILL** result in severe personal injury or death if the proper precautions are not taken.

### WARNING

A specific hazard or unsafe practice which **COULD** result in severe personal injury or death if the proper precautions are not taken

### CAUTION

Unsafe practices which **COULD** result in personal injury if proper practices are not taken, or as a reminder of good safety practices.

# ASSEMBLY INFORMATION

Remove all wires and arrange the parts conveniently.

*NOTE: Always wear safety glasses or goggles and be careful when cutting wires and steel bands as they are under tension and will spring back when cut.*

The right and left side of the machine is determined by standing behind the machine and facing the direction the machine will travel in operation.

Lubricate all bearings and moving parts as you proceed and make sure they work freely.

Loosely install all bolts connecting mating parts before final tightening.

When tightening bolts, they must be torqued to the proper number of foot-pounds as indicated in the table unless specified. It is important that all bolts be kept tight.

On new machines, all nuts and bolts must be rechecked after a few hours of operation.

Bolt Size	Grade 2		Grade 5		Grade 8	
	Nm	Lbf ft	Nm	Lbf ft	Nm	Lbf ft
5/16-18	15	11	24	17	33	25
3/8-16	27	20	42	31	59	44
7/16-14	43	32	67	49	95	70
1/2-13	66	49	105	76	145	105
9/16-12	95	70	150	110	210	155
5/8-11	130	97	205	150	285	210
3/4-10	235	170	360	265	510	375
7/8-9	225	165	585	430	820	605
1-8	340	250	875	645	1230	910

### Standard Bolt Identification



Grade 2  
No Marks



Grade 5  
3 Marks



Grade 8  
6 Marks

When replacing a bolt, use only a bolt of the same grade or higher. Except in shear bolt applications, where you must use the same grade bolt.

Bolts with no markings are grade 2

Grade 5 bolts furnished with the machine are identified by three radial lines on the head.

Grade 8 bolts furnished with the machine are identified by six radial lines on the head.

All U-bolts are grade 5.

## Abbreviations

ASSY	Assembly
BLD	Blade
BLT	Bolt
BRKT	Bracket
CTR	Center
CP	Cup Point
(FF)	Female Female
GR	Grade of Bolt
HD	Heavy Duty
HDWE	Hardware
HLK	Hex Lock Washer
LH	Left Hand
(MF)	Male Female
MF	Main Frame
MTG	Mounting
NC	National Course Thread
NF	National Fine Thread
NLK	Nylon Lock Nut
NPT	National Pipe Thread
PLW	Plow
RH	Right Hand
SS	Screw Stop
SST	Stainless Steel
TA	Tandem
TBP	Top Bypass
W/	With
W/O	Without
WLDMT	Weldment
WSHR	Washer

# **SIGN-OFF FORM**

The manufacturer of this product follows the general standard specified by the American Society of Agricultural Engineers (ASAE) and the Occupational Safety and Health Administration (OSHA). Anyone who will be operating and/or maintaining this equipment must read and understand ALL Safety, Operation, and Maintenance information presented in this manual.

Do not operate or allow anyone else to operate this equipment until such information is reviewed. Annually review this information before the season start-up.

Make periodic reviews of SAFETY and OPERATION a standard practice for all your equipment. We feel that an untrained operator is unqualified to operate this machine.

A sign-off sheet is provided for all personnel who will be working with equipment to indicate that they have read and understood the information in the operators manual and have been instructed in the operation of the equipment.

<b>DATE</b>	<b>EMPLOYEE'S SIGNATURE</b>	<b>EMPLOYER'S SIGNATURE</b>

## **TO THE OWNER**

The machine has as standard equipment a clearance lighting package . If your unit is not equipped with this package, it can be ordered by contacting your local dealer or the factory directly.

It is the responsibility of the user to read the Operator's Manual and comply with the correct operating procedures as pertains to the operation, lubrication and maintenance of the product according to the information outlined in the Operator's Manual.

If this machine is used by an employee or is loaned or rented, make certain that the operator(s), prior to operating, is instructed in the proper use and reviews and understands the Operator's Manual. This machine should only be operated by a trained operator that has been qualified to operate this machine.

The user is responsible for inspecting his/her machine and for having parts repaired or replaced when continued use of this product would cause damage or excessive wear to the other parts.

## **MODIFICATIONS**

It is company policy to improve its products whenever possible and practical to do so. We reserve the right to make changes, improvements and modifications at any time without incurring obligation to make such changes, improvements on any equipment sold previously

This product is equipped with a serial number tag to track the unit. The serial number tag is located on the inside of the outer frame tube in the front left corner of the main frame. Use the information on this tag to identify when ordering parts or requesting information

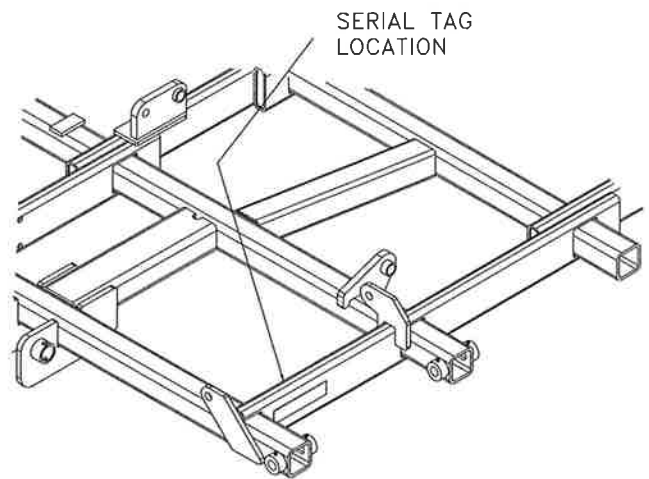

## **MACHINE ASSEMBLY** **PROCEDURE**

**Read all assembly instructions before starting assembly of this machine.**

This machine will be packed in a condensed format, usually on a packaging skid. This package will be very heavy and will require the use of some type of forklift to unload the package and break down the parts. The forklift must have a minimum lift capacity of 4082 kg (9000 lbs). Because the various frame components are arranged in a vertical manner, any handling equipment must be able to adequately lift and position to a height of 3.7 m (12 ft).

Once bundled skids have been properly delivered and positioned in a hard, flat and level area, the various frame parts can be removed.



**WARNING: The components banded together are heavy and could fall if the bands were removed. Make sure the component parts are properly supported before removing any bands.**

Once the bundle has been broken down into the individual components locate the main frame of the machine. Assembly of this machine will require some type of stands to support the components during assembly. Each stand should be at least 36 in (915 mm) tall and be able to support at least 907 kg (2000 lbs).

Position the main frame on the work stands in the center of the assembly area.

*NOTE: Hardware to secure the components is noted in the assembly information. Unless otherwise specified, all nuts are top lock nuts. When assembling the components, do not tighten the lock nuts until all parts have been assembled. Tighten the nuts to hold*

*the parts in position, but still allow adjustments to be made.*

Locate the main frame and wing packer towers and attach to the rear of the frame, secure with the mast tubes. Assemble the center packer mount to the center packer lift brackets and secure with axle clamps and hardware. Slide the inner lift axle pivots onto the end of the center packer mount, slide the rear lift mast into position shown. Slide the center packer hanger onto the ends of the center packer mount and secure.

Position and support the inner wings level with the main frame and secure with the noted hardware. Mount the outer wing hinge components to the inner and outer wing and attach the outer wing to the inner wing. Support all frames with work stands.

Mount the shank assemblies in the positions shown on shank mounting location pages. Mount any required stubs needed to locate all the shank assemblies.

*NOTE: It may be necessary to shift the shanks laterally to allow clearance for the shank or springs to clear. There are also a number of shanks which mount to frame components and do not use the standard top plate.*

Mount the pre-assembled wing lift assemblies to the front frame tubes as located on the shank spacing chart.

Attach the wing packer mounts in the same manner as noted above. Mount the front part of the rear hitch to the main frame and secure as noted.

Position the mainframe anchor assembly on the top tubes of the main frame and secure loosely. Further tie the mainframe anchor assembly to the main frame with the truss straps. Position the front wing rest/lock and secure. Locate the front and rear wing fold anchors and secure to the main inner wings.

Attach the packer lift anchors, center in the adjustment slot, and adjustment bolt to all rear packer sections. Secure the front lift masts to the front main frame tube. Place the inner and outer wing rests as noted and loosely secure.

Locate and attach the Main Lift Hitch and related parts to the front of the main frame with the pins provided, secure with noted hardware. Assemble the main hitch cross and main hitch as shown, insert the front axle pivots, hubs and spindles and tires. **Do not attach the front hitch cross to the main lift hitch at this point.**

Position and attach the left and right rear lift axles to the lift axle pivots and secure. Insert hubs and spindles and rims and tires.

## **HYDRAULIC SYSTEM ASSEMBLY**

The drill portion of this machine requires three hydraulic circuits to properly operate.

### **MAIN LIFT CIRCUIT**

The main lift circuit is used to raise and lower the complete machine. It consists of a set of 203 mm (8 in) stroke sequencing cylinders of varying diameter which, when properly connected and adjusted, will move the machine in a level manner. Machine operating depth is maintained by using stroke control collars of varying length on each lift cylinder (see operating instructions for more information).

Locate and retrieve the lift cylinders and move to the lift axle areas. Refer to cylinder location instructions to assemble the cylinders to the lift anchors, rear packer and main lift hitch. Cylinders are mounted with the rod ends up, secured with the pins noted or with the pins that are supplied in the cylinder boxes. Locking roll pins or cotter keys can be used to secure the pins. Locate the cylinder stop collar packages and clip to the storage rods provided at each cylinder location.

Locate the appropriate hydraulic hoses and

position in the general areas of the machine as shown in the hose routing instructions (88-93). Install noted fittings in all cylinders in the circuit. As shown this system requires that the hoses connect the cylinder's in the correct sequence. Hoses are routed from the tractor to the base end of the largest cylinders, from the rod end of that cylinder to the base end of the next smaller diameter cylinder, etc.

### **HOSE ROUTING/CLAMPING**

Hose should be generally routed as shown in the routing instruction. Since there are many variables to the routing of hoses it is recommended that hoses be routed along frame members as shown. Special attention should be paid to routing hoses away from potential pinch points when folding wings or when working. Note the need for more hose at the hinge points, route the hoses so there is additional length to move as components move. Hose mounting points are welded to the frame members and hoses are secured with clamps and bolts. Loosely secure hoses to check placement and secure when hoses are in desired position.

## WING FOLD CIRCUIT

The inner and outer wings are operated by large 127 mm (5 in) hydraulic cylinders. Refer to the cylinder location instructions for proper orientation of the cylinders. Attach the base ends of the outer wing fold cylinders with the bolts or pins noted. Position a wood block spacer under the cylinder to hold the rod end of the cylinder above the outer wing fold linkage attach point. Attach the base ends of the main wing fold cylinders to the main frame anchor assemble as shown. Support the end of the cylinders to allow room for the rods to fuller extend without contacting any frame parts.

Locate the required hoses for this circuit, connect the circuit as shown, route and loosely secure the hose with the plastic ties provided.

## TRANSPORT LIFT CIRCUIT

There are two sets of lift cylinders that are used to lift and hold the machine in the transport position. These cylinders are connected in a simple circuit as noted in the assembly instructions. Attach the base end of the 102 to 305 mm (4 to 12 in) cylinders to the anchor on the main frame and the rod end to the front lift mast. Attach the base end of the 102x406 mm (4x16 in) cylinders to the rear lift mast and support the cylinder with a block to allow full extension without contacting machine elements. Locate the required hoses for this circuit, connect the circuit as shown, route and loosely secure the hose with the plastic ties provided.

## HYDRAULIC SYSTEM CHARGING

Once all hydraulic circuits have been assembled as noted and the hoses have been attached it is important to properly charge the system.

*IMPORTANT: The systems on this machine will require a large amount of hydraulic oil to fully charge and purge. Make sure the system used to charge the circuits has adequate capacity and a minimum hydraulic pressure of 1995 kPa (2700 psi). Oil may need to be added to the pump reservoir to complete charging. All circuits must be fully charged before lifting or folding this machine.*

## CHARGING MAIN LIFT CIRCUIT

Sequencing systems require that all cylinders be fully charged with oil. This is accomplished by forcing oil into the main or master cylinder, in this case the 127 b 203 mm (5x8 in) cylinder located on the front hitch. When the cylinder is charged with oil and fully extended it will move into a bypass mode, oil will move out of the rod end port and to the next cylinder in the sequence. That cylinder will extend into bypass and move oil to the next, etc. This initial process can take a considerable amount of time. While charging the main lift system make certain that all cylinders in the circuit are able to fully extend without contacting any frame components. This is the reason the front pivot axles and main hitch cross should not be attached.

Once both sides of the machines main lift



cylinders have extended fully, retract the cylinders. All cylinders should retract in sequence. Fully extend the cylinders again and check to ensure all cylinders are purged and fully extended.

Once the main lift circuits have been charged the front wheel lifts can be completed as shown. Attach the front hitch cross with the pins and hardware required.

### **CHARGING WING FOLD CIRCUIT**

Connect the wing fold circuit to the oil supply and apply pressure. Again the main frame fold cylinders will slowly extend to full extension or all cylinders may extend depending on the pressure required to extend. Make certain that the cylinders do not contact machine parts while extending and retracting.

*NOTE: All wing fold cylinders have an integral restrictor in the rod end. This restrictor can make the charging of the system seem slow but is necessary. All wing fold cylinders must be fully charged and cycled before connecting the rod ends to the lift brackets.*

Once all cylinders have been charged, fully retracted and fully extended, attach the rod ends to the noted anchor points.

### **CHARGING TRANSPORT LIFT CIRCUIT**

As with the wing fold circuit, support the cylinder while extending and charging. Once the circuit has been charged and cycled, attach the rod ends of the cylinders to the appropriate anchor points and secure.

### **REAR PACKER ASSEMBLY**

The main components of the rear packers are pre-assembled. Locate these assemblies and move to the rear of the machine. It will require that the top pivot bolt be removed to attach the packer pivots to the rear packer mounts. Disassemble, mount to the rear packer mounts as shown and reassemble. Insert the packer pressure spring and secure with the hardware noted. Initially tighten the spring bolt to lightly compress the spring.

Mount the packer wheels and securely tighten all mounting bolts. Refer to the operational information for additional information on packer settings.

# OPERATIONAL INFORMATION

## INITIAL/PRE-FIELD SETTINGS

Once the machine has been fully assembled and before the machine is folded for transport check to ensure that all hardware has been properly tightened to specifications noted. Check to ensure that there are no loose parts or tools anywhere on the machine.

Attach the machine to the tractor that will be used with the machine. The tractor must have a minimum of 343 kW (460 hp) for 15.2 m (50 ft) machines and 373 kW (500 hp) for 18.3 m (60 ft) machines.

Connect all hoses to the tractor. Raise the machine to full height with the main lift cylinders and hold the lever to purge the system. Move to a flat area, preferably a level concrete surface and position the machine in an open area. Activate the transport lift circuit to raise the rear transport wheels so that the rear of the machine is carried by the rear packer wheels.

Make certain that all points or attachments are mounted on the machine before doing any pre-field settings.

*NOTE: Any settings completed in the yard may need to be altered once the machine is in field use. Pre-field settings will make the final field settings less challenging.*

Once the main lift system has been purged and sequenced lower the machine down so the shanks are 50 to 76 mm (2 to 3 in) above the ground as shown below. Measure the distance to the ground from a point of a shank on the front rank of the machine. Pick a shank on the outside of the main frame. Measure from the same point of a shank on outside rear of the machine.

If the machine is not level front to rear an adjustment will need to be made to the rear packer anchor point. Loosen the two anchor bolts to allow the anchor to slide. Use the adjust bolt to raise or lower the rear of the main frame to level the machine.

Check the side to side level of the main frame in a similar manner. Adjust the remaining main frame rear packer anchor to level the machine side to side.

To relieve the pressure on the adjustment anchors to make the adjusting easier, lower the machine to the ground to take the load off the anchors. Adjust as required, fully extend the cylinders to properly sequence the system and lower to the machine so the shanks are 50 to 76 mm (2 to 3 in) off the ground. Measure as before and continue to fine tune the machine level.

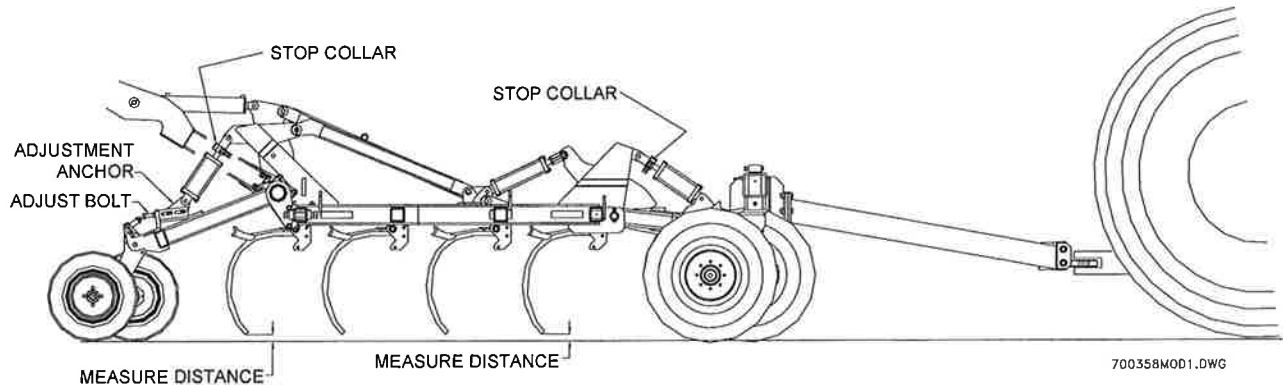

## PRE-FIELD SETTINGS INNER AND OUTER WINGS

Check the front to rear level of the inner wings. As noted below the measured distance between the shank and the ground should be the same as the main frame. To adjust the level front to rear both the front lift wheel and rear packer can be adjusted. Check the distance at the front outside shank location on the wing versus the height of the main frame. If the front of the wing needs to be altered, loosen the jam nuts on the front adjust screw and adjust as required. Once the front of the wing is at the same depth as the main frame, lock the front into position. Measure the rear shank height and adjust the rear packer adjust anchor as required.

Repeat the same procedure for the outer wing and wings on other side of the main frame, levelling the wings front to rear and setting the wing height to the main frame.

As with the main frame, lower the machine to relieve the load on the various anchors to allow easier adjustment,

Once the adjustments to the various anchors have been completed there should be minimal need to readjust these settings. When the machine has been moved to the field and dropped to the seeding depth it is important to recheck the front to rear level and depth of each section. Variations in soil type and loading will effect the operational depth and readjustments may be required.

The adjustments noted above are to level the machine. **To control the seeding depth the stop collars on each lift cylinder must be changed.** A full set of stop collars of varying thickness is provided for each lift cylinder. Use these stop collars to set the seeding depth of the machine. If the seeding depth is too deep, stop collars need to be added to each cylinder. **The cylinders have been sized to allow the addition or removal of the same thickness of stop collars from each cylinder to control depth of seeding.** For example: if the machine is seeding deep all cylinders would have a 6.4 mm (1/4 in) stop collar added. As the machine is cycled it may require that the lift system be re-sequenced. Raise the machine and hold the cylinders in the extended position until all cylinders have been purged.

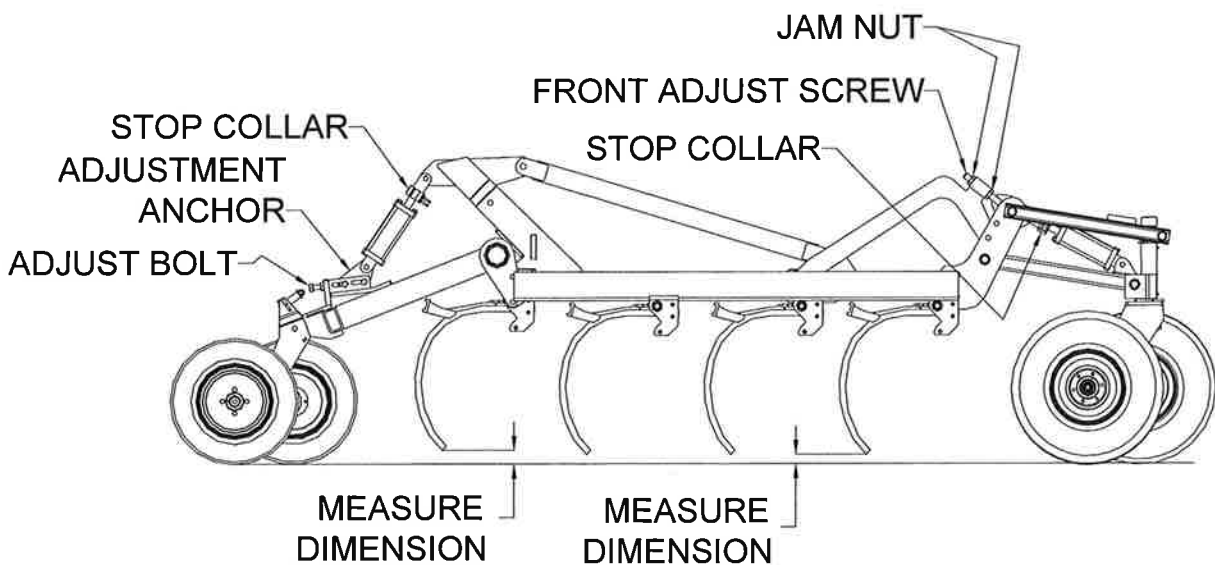

## WING FOLDING/UNFOLDING

After the machine has been charged and levelled it can be winged up to the transport position. Make certain that the machine is hitched to a tractor and setting on a level surface when folding the wings. If possible move the machine to an area where the ground is not as hard but has a loose composition. Move all personnel away from the path of the wings but pay attention to the components when folding.

Before folding the wings, raise the machine to full height with the main lift circuit. Activate the transport circuit and extend the front and rear lift cylinder fully. Place the channel locks into position on the transport cylinders.



**WARNING: Install channel locks on each (4) transport lift cylinders before attempting to fold the wings or transporting the machine.**

Once channel locks are in position, activate the wing fold circuit. All cylinders should began to retract and start folding the outer wings. When folding for the first time pay attention to the movement of hydraulic or feed hoses, it may require that hoses be moved to prevent kinking or pinching. As the outer wings began to fold the packer wheels at the outer hinge point may skid. This should not be a problem when folding the machine in loose ground conditions. Skidding can be reduced by slowly moving forward with the machine as the wings are folded. Forward movement is only required when the wing packer wheels are skidding.



**WARNING: Do not allow any people or children to walk under a wing at any time while it is folding or unfolding. Front gage wheels on the wings can abruptly rotate as the wings are folded, do not allow any personnel to be in the wing fold area or on the machine.**

As the outer wings fold over the main wings check to ensure that the wing rest contacts and supports the outer wing . Slightly raise the outer wing and adjust wing rest if required.

Once both outer wings have been folded, continue to fold the inner wings. These wings should fold to a vertical position. As the wings approach the vertical position activate the main lift circuit and pull the packer wheels and front lift wheels up. This is necessary to allow clearance in the center of the machine and reduce the transport width. The outer wing should rest on the inner wing rest mounted on the mainframe. If contact is not made readjust the location of the rest.

**IMPORTANT:** The front main frame wing rest has provisions to lock or pin the wings for transport. Insert the locking pin in the clevis on the front wing lock. Make certain that the wing is unlocked before attempting to unfold the wings. Approach the wings from the front when locking or unlocking the wings, never go into the wing fold path to lock or unlock the wings.

To unfold the wings reverse the process. As the inner wing approaches the ground, activate the main lift circuitry and lower the packer and front lift wheels. The main lift and rear packer wheels must be on the ground to support the wings when they touch down. The wing fold circuitry has a sequence valve to properly unfold the wings. This valve is designed to prevent the outer wings from moving before the main wings have completely unfolded. If the outer wing wants to move excessively before the inner wing is unfolded or the outer wing cylinders don't full extend, adjust the sequence valve by loosening the locking nut and turning the adjustment screw clockwise. Adjust as required and secure setting with the locking nut.

## **TRANSPORTING THE MACHINE**

The machine must be fully folded with the wings locked before transporting.



**WARNING: The channel locks must be installed in the front and rear transport cylinders before transporting the machine.**

Store the channel locks on the storage bars located on the front cross bar and rear lift axles.

When hitched to the tractor and with a seeder cart attached to the rear hitch the whole machine is quite long. Care must be taken when transporting. When turning the seeder unit will rotate about the rear transport wheels requiring a large turning radius. Never transport the complete machine at high speeds during field use or on the highway.



**WARNING: Do not exceed the maximum transport speed of 25 km/h (15 mph).**

Make certain the tractor is properly weighted to handle the heavy pull load. Use care when moving across uneven ground or poor roads. Reduce the speed of the machine on narrow, rough roads. Do not carry the machine off the side of the road where the right side carrying wheels are off the main roadbed. If it is necessary to move off the road to allow traffic to pass, pull off the road slowly or stop and allow traffic to pass.

Do not back the machine up when attached to

the seeder supply tank. With the wings folded and no tank is attached it is possible to carefully back the machine a short distance.



**WARNING: Lower the main wings to the ground and make sure the main frame carrying wheels are rotated to the front BEFORE unhitching the machine from the tractor.**

## **STORAGE**

Machine should be stored inside and unfolded if possible. Park the machine in a flat, level area. Unfold the wings to remove the load from the main frame carrying wheels.



**WARNING: Lower the main wings and the entire machine to the ground BEFORE removing the transport channel locks. Relieve the system hydraulic pressure in the wing fold circuit before storing the machine.**

If the machine is parked on a soft surface place support under the lift wheels to prevent sinking into the ground. When storing the machine at any time, if hitched to a tractor or not, always relieve the pressure to the wing fold circuit. This can be accomplished by using the float circuit of the tractor. Move the hydraulic lever to the float position to relieve pressure in the wing fold circuit before turning off or unhitching the tractor.

## FIELD OPERATIONS

Following the completion of the assembly and pre-field settings the machine can be attached to the rear seed supply system. Refer to the provided information on the supply system for setup and operational information on that portion of the seeding system.

Enter the field and unfold the main/ outer wings of the machine. Pressurize the main lift hydraulic circuit to sequence the main lift cylinders. Activate the transport lift circuit, remove and store the channel locks. Fully retract the transport cylinders. Pull forward with the air system engaged and lower the machine into the ground. Set the initial depth of operation without using any stop collars. Stop and check the depth of operation of the main frame. Install the required amount of stop collars in the main frame cylinders to place the machine at the desired working depth. The cylinders should be fully retracted and held by stop collars. Check the front and rear and side to side depth of operation and adjust the rear packer adjustment anchor or front lift axles as noted in the PRE-FIELD SETTINGS instructions.

Once main frame is set to desired depth, raise the machine to full height and hold for 1 minute. Place the same combination of stop collars in all remaining lift cylinders. Lower the machine into the ground while moving forward and stop. Check the depth and level of the wings and readjust as noted in the PRE-FIELD SETTINGS if required.

**IMPORTANT:** If main frame or wing depth needs to be changed to be level, do not add or remove stop collars from that cylinder. Readjust the various adjustment anchors.

With a sequencing lift system if one cylinder is stopped by use of additional stop collars all cylinders in the circuit will stop and the depth settings on the remaining cylinders in the circuit will be impacted. **All lift cylinders should use the same combination or amount of stop collars.**

Move through the field and observe the general operation of the machine. Check the movement of the rear packers arms. If there is excessive vertical movement or bouncing of the packers wheels it may require that the packer compression spring be tightened. It is generally best to have limited pivoting of the packer arms when seeding. Arms should only rotate when encountering a large soil mound or rocks. Tighten the lock nut on the packer spring to increase the holding force.

As with all machinery it will be necessary to check the tightness of all hardware after 4 to 6 hours of use. As the various components seat there will be parts that need to be adjusted. Hardware that is retaining parts that do not rotate or move should be checked after the first day of use and weekly after that. Parts such as packer wheel pivots or parts that need to wear in or seat should be checked and adjusted more frequently.

Refer to the GREASING information on Page 98-99 for grease locations and frequency.

## **TIRE INFLATION**

The front lift and rear transport tires should be inflated to 483 to 518 kPa (70 to 75 psi). If there appears to be sidewall flex in the large front center lift tires the pressure can be increased to 552 to 586 kPa (80 to 85 psi).

The rear packer tires can be set at 103 to 241 kPa (15 to 35 psi) depending on packing and load requirements. A lower setting will allow the tires to pack a somewhat wider area and shed mud, but there must be sufficient tire pressure to limit sidewall flex. Set initial pressure to 105 kPa (15 psi) and increase or decrease as conditions dictate.



**WARNING: Lower the machine to the ground, shut off the tractor engine, and remove the key before servicing the machine or when not in use.**

**DO NO allow anyone to ride on the machine.**

**Keep all persons clear of the machine and tractor when the engine is operating.**

## **UNLESS SPECIFIED ALL BOLTS ARE SECURED WITH TOP-LOCK LOCK NUTS**

PART NO.	DESCRIPTION
88125	NUT HEX 1-8NC 5Z
88141	NUT JAM 1-8NC 5Z
88430	NUT 2POSLK 1-1/4-7NC 5Z
88622	NUT JAM 1-1/4-7NC 5Z
88658	NUT TOP LK 1-8NC 5Z
88659	NUT TOP LK 3/8-16NC 5Z
88661	NUT TOP LK 1/2-13NC 5Z
88665	NUT TOP LK 3/4-10NC 5Z
88831	NUT TOP LK 7/8-9NC 5Z
88845	NUT TOP LK 5/8-11NC 5Z

## FULL MACHINE OVERVIEW

This illustration shows an overview of the complete 18.3 M (60 FT) machine as a reference guide to understanding the general layout of the machine. The layout of the 15.2 M (50 FT) machine is similar. Please refer to the individual assembly instructions for specific information.

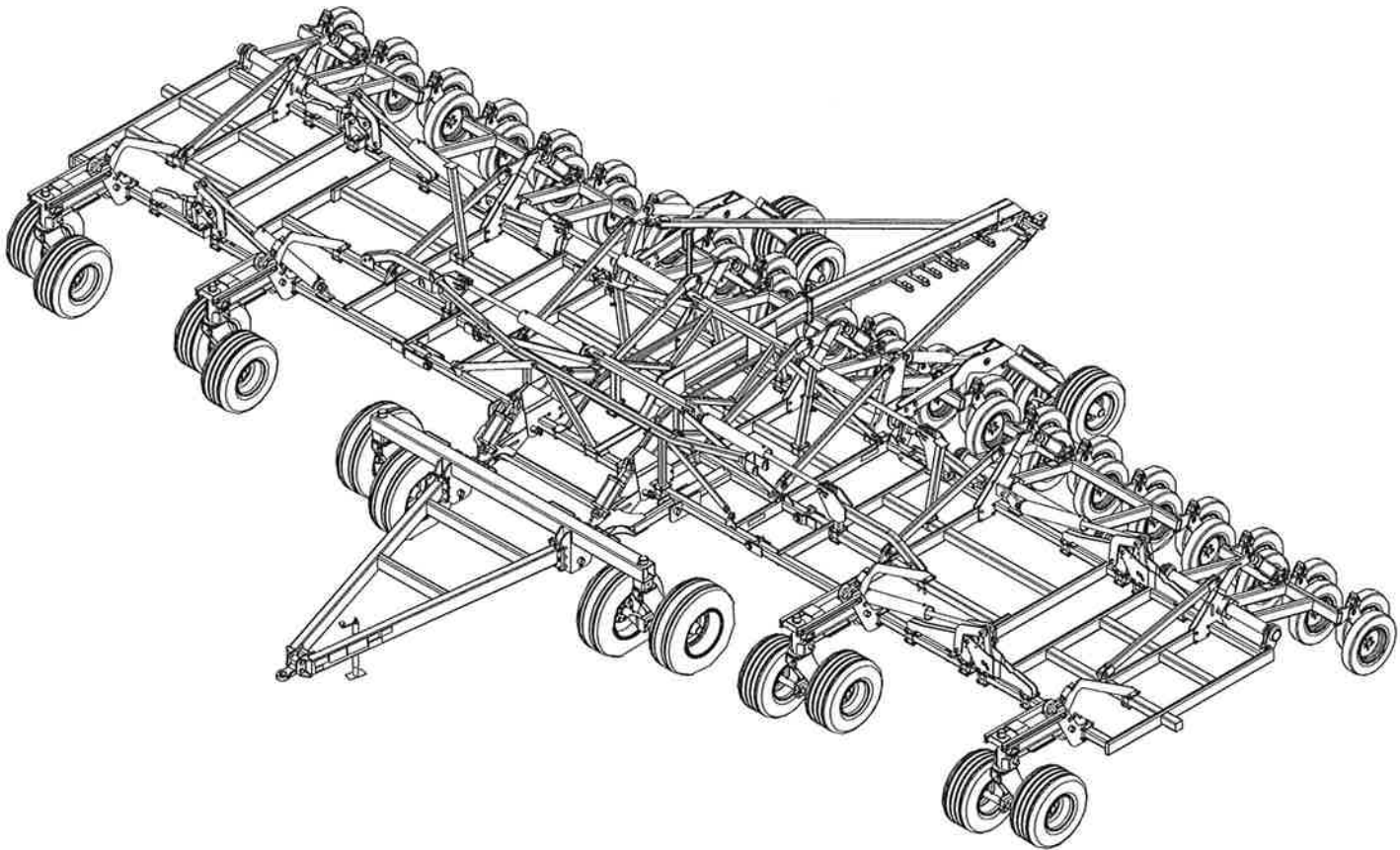

**HDW KIT  
74285-2**

Information in these boxes on the following pages reference the corresponding Hardware Kit. The hardware kit contains the hardware used to assemble the portion of the machine noted on that page.



# INITIAL ASSEMBLY STEPS

Read the general assembly procedure instructions as noted on Pg 6-9. The following pages note an illustrated path you can follow to assemble this unit. Some components need to be in place before the next components are assembled.

The first components to be assembled to the main frame should be the center packer mount which attaches to the rear of the main frame. As noted below and illustrated in more detail on Pg 48-49, these components should be mounted first once the main frame has been placed and properly supported with work stands. You only need to mount the components noted below at this point.

Position and loosely mount the front hitch (243908) as noted on Pg 18 or Pg 20. Position and loosely mount the main frame anchor (244865) and associated components as noted on Pg 18 or Pg 20.

**It is strongly recommended that all mounting hardware be left loose until all components have been mounted. Sufficiently tighten hardware to hold components safely in position and completely tighten all hardware once all parts are in place. It may require that line up or other assembly tools be used in this assembly.**

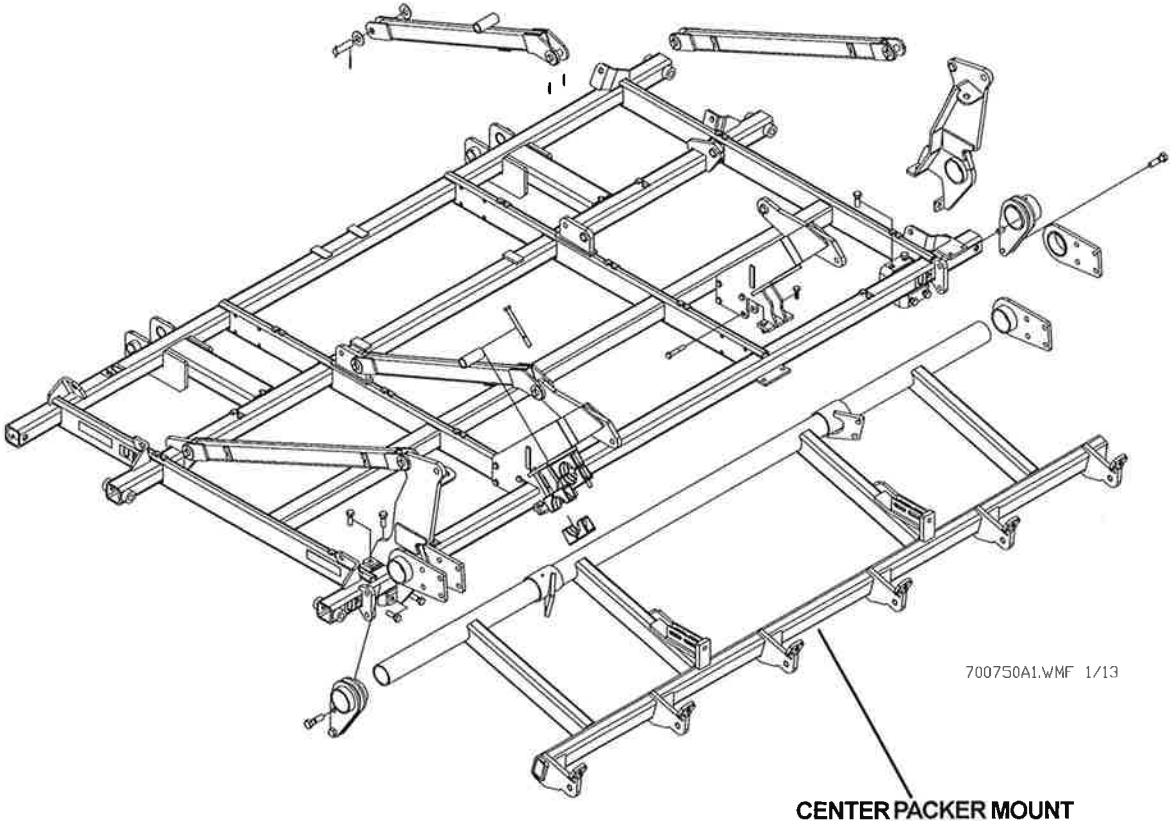

# MAIN FRAME ASSEMBLY - 15.2 M (50 FT) UNIT

**HDW KIT  
79973-1**

**POSITION 243908-ATD FRONT HITCH  
CENTERED Laterally ON MAIN FRAME  
BEFORE ADDING 244865 MAIN FRAME  
ANCHOR - SEE PAGE 54 FOR MOUNTING  
INFORMATION.**

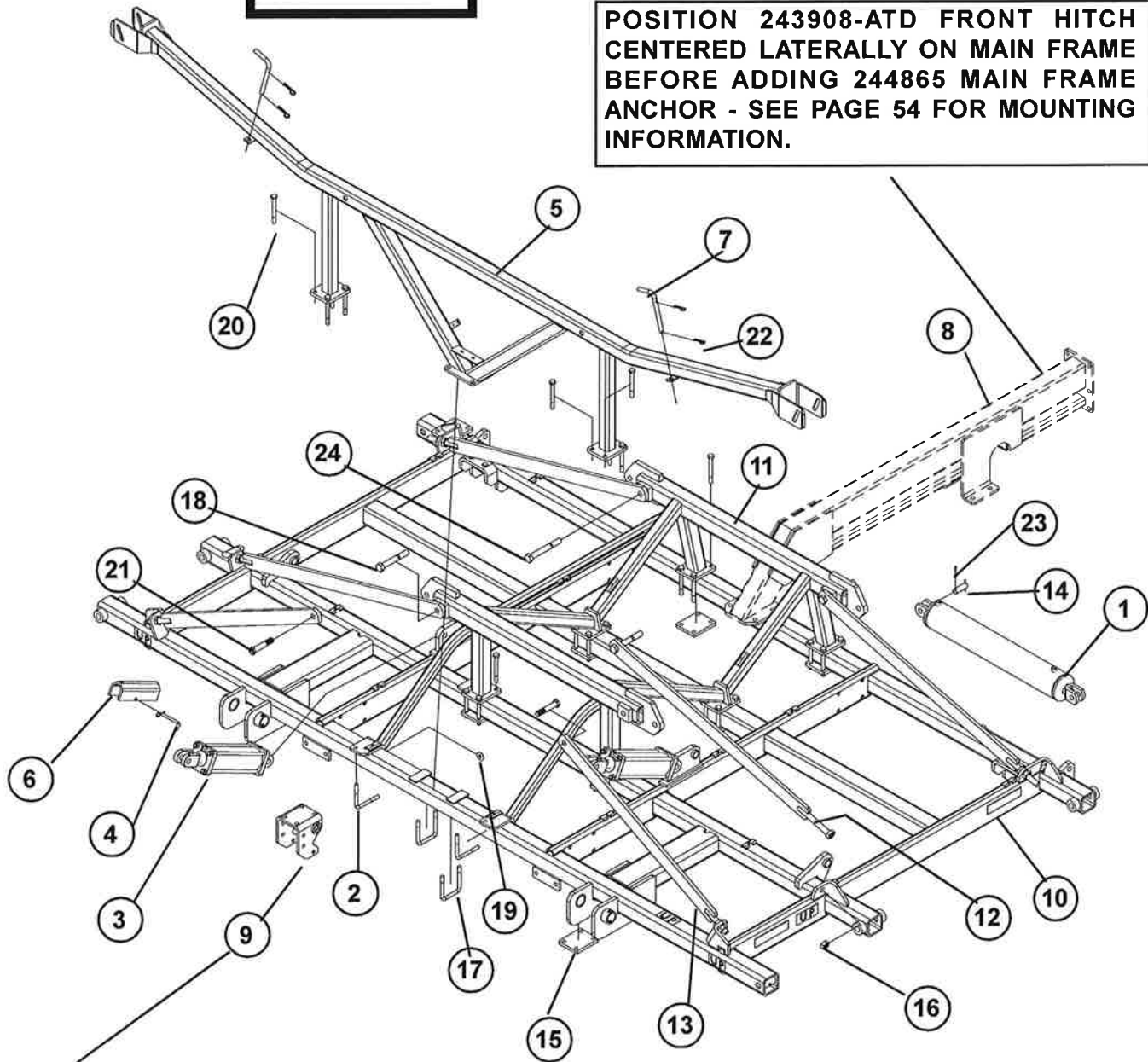

**MOUNT SHANK TO TRUSS STRAP MOUNT (241538),  
USE 5/8" BOLT IN FRONT HOLES.**

**UNLESS SPECIFIED, ALL HARDWARE IS SECURED WITH MATCHING LOCK NUTS**

# MAIN FRAME ASSEMBLY - 15.2 M (50 FT) UNIT

ITEM	PART NO.	DESCRIPTION	QTY
1	20966F	HYD CYL 5X30 ILP FGS #A519CY07	4
2	22290	L-BOLT 5/8 IN FOR 4 SQ TUBE	2
3	234764	HYD CYL 4" X 12" (BLACK)	2
4	234811	1/2 X 4 BENT PIN W/HAIRPIN	2
5	241538	TRUSS STRAP MOUNT	1
6	241640	12 INCH CHANNEL LOCK	12
7	241652	WING LOCK PIN (PLATED)	2
8	243908	ATD HITCH - SHORT FRONT - REF	1
9	243957	SHANK HOLDER - REFERENCE	1
10	244832	MAIN FRAME - 5015/6015 ATD	1
11	244865	MAIN FRAME ANCHOR 50/6015 ATD	1
12	244881	TRUSS STRAP	4
13	244887	TRUSS STRAP	2
14	42473	HEADLESS PIN (H) (2) 1X2-3/8	4
15	62271	FRAME PLATE (RED)	7
16	88125	NUT HEX 1-8NC 5Z	12
17	88145	BLT-U 5/8-11NCX4X5-1/4 Z	2
18	88181	BLT HEX 1-8NC X 7 5Z	2
19	88277	WSHR FLAT 5/8(11/16 X 1-3/4ACT) Z	2
20	88295	BLT HEX 5/8-11NC X 6 5Z	32
21	88312	BLT HEX 1-8NC X 5 5Z	2
22	88352	PIN SPRLK 3/16 X 3-1/4 PRLS6 Z	4
23	88767	PIN ROLL 1/4DIA X 2-1/2 Z	8
24	89359	BLT HEX 1-8NC X 8 8YZ	2

# MAIN FRAME ASSEMBLY - 18.3 M (60 FT) UNIT

POSITION 243908-ATD FRONT HITCH CENTERED LATERALLY ON MAIN FRAME BEFORE ADDING 244865 MAIN FRAME ANCHOR - SEE PAGE 54 FOR MOUNTING INFORMATION.

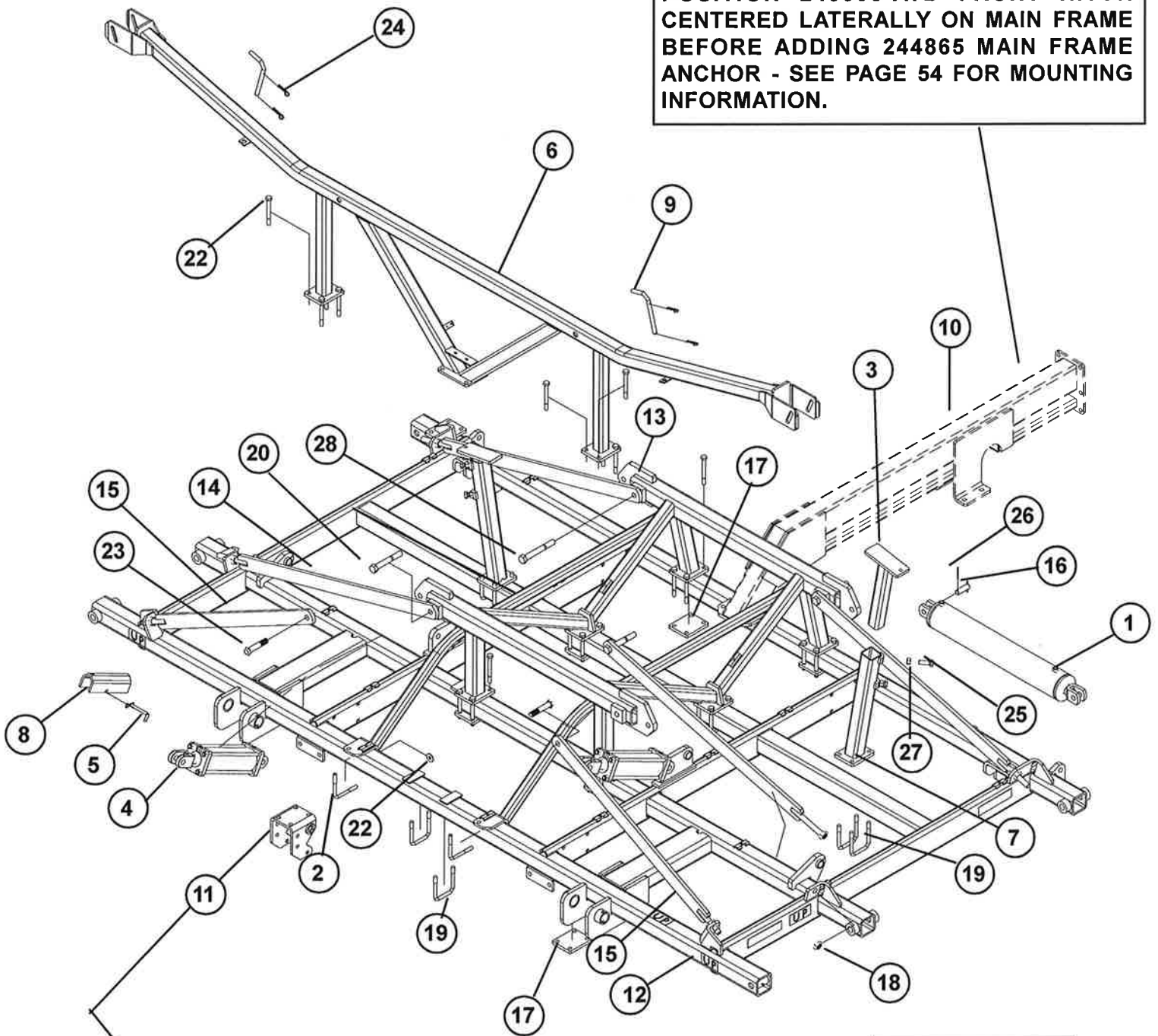

MOUNT SHANK TO TRUSS STRAP MOUNT (241538),  
USE 5/8" BOLT IN FRONT HOLES.

**HDW KIT  
79973-2**

**UNLESS SPECIFIED, ALL HARDWARE IS SECURED WITH MATCHING LOCK NUTS**

# MAIN FRAME ASSEMBLY - 18.3 M (60 FT) UNIT

ITEM	PART NO.	DESCRIPTION	QTY
1	20966F	HYD CYL 5X30 ILP FGS #A519CY07	2
2	22290	L-BOLT 5/8 IN FOR 4 SQ TUBE	2
3	233552	WING REST SLIDE TUBE	2
4	234764	HYD CYL 4" X 12" (BLACK)	2
5	234811	1/2 X 4 BENT PIN W/HAIRPIN	2
6	241538	TRUSS STRAP MOUNT	1
7	241634	INNER WING REST - ATD	2
8	241640	12 INCH CHANNEL LOCK	2
9	241652	WING LOCK PIN (PLATED)	2
10	243908	ATD HITCH - SHORT FRONT - REF	1
11	243957	SHANK HOLDER - REFERENCE	1
12	244832	MAIN FRAME - 5015/6015 ATD	1
13	244865	MAIN FRAME ANCHOR 50/6015 ATD	1
14	244881	TRUSS STRAP	4
15	244887	TRUSS STRAP	2
16	42473	HEADLESS PIN (H) (2) 1X2-3/8	4
17	62271	FRAME PLATE (RED)	7
18	88125	NUT HEX 1-8NC 5Z	12
19	88145	BLT-U 5/8-11NCX4X5-1/4 Z	8
20	88181	BLT HEX 1-8NC X 7 5Z	2
21	88277	WSHR FLAT 5/8(11/16 X 1-3/4ACT) Z	2
22	88295	BLT HEX 5/8-11NC X 6 5Z	32
23	88312	BLT HEX 1-8NC X 5 5Z	2
24	88352	PIN SPRLK 3/16 X 3-1/4 PRLS6 Z	4
25	88604	BLT HEX 3/4-10NC X 2 5Z	4
26	88767	PIN ROLL 1/4DIA X 2-1/2 Z	8
27	89080	NUT HEX 3/4-10NC 8YZ	4
28	89359	BLT HEX 1-8NC X 8 8YZ	2

# FRONT HITCH ASSEMBLY

**HDW KIT  
79973-3**

NOTE: THIS IS A TWO POSITION ANCHOR, SET INITIALLY AS NOTED WITH INDEX NOTCH FACING UP. IF FRONT OF MAIN FRAME NEEDS TO BE LOWERED SET WITH NOTCH DOWN. MAKE CERTAIN BOTH ANCHORS ARE SET THE SAME.

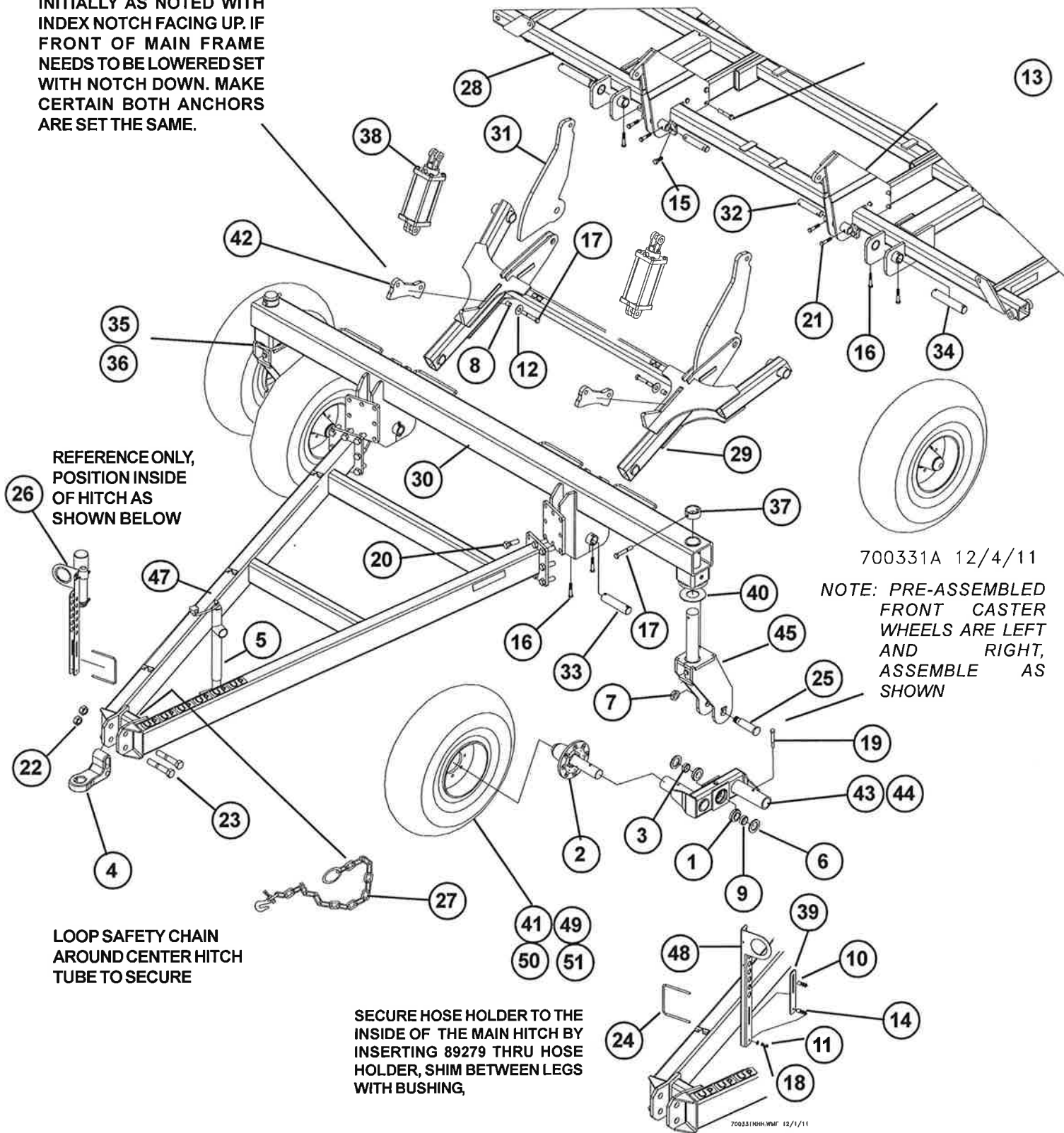

REFERENCE ONLY, POSITION INSIDE OF HITCH AS SHOWN BELOW

700331A 12/4/11  
NOTE: PRE-ASSEMBLED FRONT CASTER WHEELS ARE LEFT AND RIGHT, ASSEMBLE AS SHOWN

LOOP SAFETY CHAIN AROUND CENTER HITCH TUBE TO SECURE

SECURE HOSE HOLDER TO THE INSIDE OF THE MAIN HITCH BY INSERTING 89279 THRU HOSE HOLDER, SHIM BETWEEN LEGS WITH BUSHING,

# FRONT HITCH ASSEMBLY

ITEM	PART NO.	DESCRIPTION	QTY
1	12103	BEARING CONE 1-3/4ID (25580)	4
2	16154	2-1/2IN HUB&SPINDLE ASSY	4
3	16278	BEARING BUSHING	2
4	18236	CAST DUAL HITCH	1
5	24415	JACK	1
6	26120	SEAL	4
7	42082	1-1/2NF HYDRA JAM LOCK NUT	2
8	51468	BUSHING	2
9	54599	WALKER BEARING BUSHING	2
10	59884	3/4OD X .75 IDLER BUSHING	2
11	88103	NUT HEX 3/8-16NC 5Z	2
12	88131	WSHR FLAT 3/4(13/16X2ACT) Z	2
13	88272	BLT HEX 3/4-10NCX4 5Z	8
14	88282	WSHR FLAT 3/8(7/16X1ACT) Z	2
15	88290	BLT HEX 3/4-10NCX2 8YZ	4
16	88292	BLT HEX 5/8-11NCX3-1/2 5Z	8
17	88305	BLT HEX 3/4-10NCX5 5Z	4
18	88362	WSHR HLK 3/8ID Z	2
19	88381	BLT HEX 5/8-11NCX4-1/2 5Z	4
20	88399	BLT HEX 1-8NCX3 5Z	16
21	88408	BLT HEX 5/8-11NCX3 5Z	4
22	88430	NUT 2POSLK 1-1/4-7NC 5Z	2
23	89134	BLT HEX 1-1/4-7NCX7 5Z	2
24	89279	BLT-U 3/8-16NCX7X6-1/4 Z	1
25	235245	TANDEM PIN	2
26	236094	UTILITY POLEKIT 5 X 7	1
27	238225	40K SAFETY CHAIN	1
28	244832	MAIN FRAME - ATD	1
29	240447	MAIN LIFT HITCH - ATD	2
30	240466	MAIN HITCH CROSS	1
31	240498	TRANSPORT ANCHOR	2
32	241519	PIVOT PIN	2
33	241546	FRONT PIN (PLATED)	2
34	241547	FRONT PIN (PLATED)	2
35	241552	LEFT MAIN AXLE WALKER ASSY	1
36	241553	RIGHT MAIN AXLE WALKER ASSY	1
37	241563	TOP TUBE	2
38	241624	HYD CYL 5X8 SEQ	2
39	241777	BACKING PLATE	1
40	242932	LARGE WEAR PLATE	2
41	320362	WHL W-440/55R18 159AFS24TL	4
42	350918	MAIN HITCH LIFT ANCHOR	2
43	221347D1	RIGHT 3X11 HD WALKING TANDEM	1
44	221347D1R	LEFT 3X11 HD WALKING TANDEM	1
45	237722R1	FRONT AXLE PIVOT -ATD	2
46	240493	FRONT LIFT MAST	2
47	240469	MAIN HITCH - ATD	1
48	236142	FORMED CHANNEL-HYD HOSE BRKT	1
49	320383	WHEEL-14 X 18" W/HOLE (BLACK)	1
50	320384	TIRE-440/55R18IMP 159A8/B TL (GY)	1

# MAIN FRAME LEVELING

Variations in components and assembly may require the shimming of the main hitch as shown. When levelling unit in the operating position **one side of the front of the main frame** may ride lower. To raise the front corner of the main frame utilize the leveling shims under the main anchor as shown to raise the low corner. Each 1/8" thick shim will raise the frame approximately 1/4". **Use shims on one side only**, make certain the main anchors are set the same. Shims and hardware are provided or are available from WIL-RICH parts (351665)

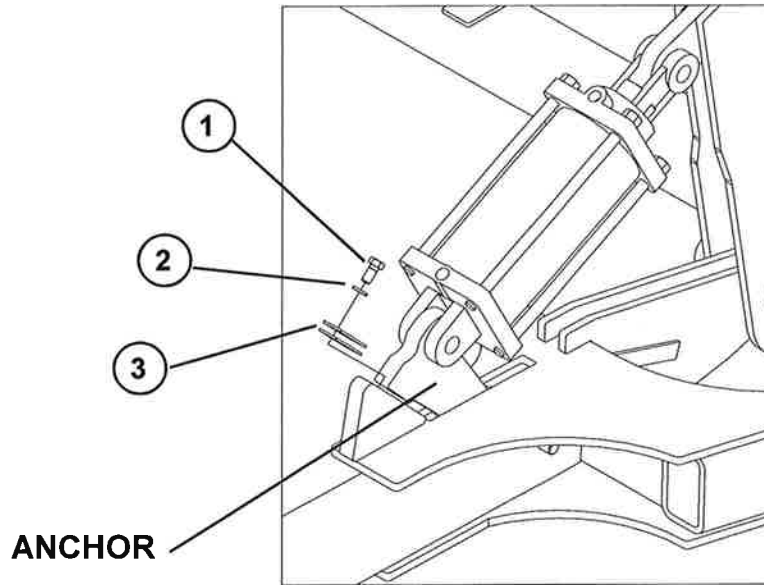

700331S1 4/3/12

ITEM	PART NO	DESCRIPTION	QTY
1	88303	BLT HEX 1/2-13NC X 1 5Z	1
2	89015	WSHR HLK 1/2ID(9/16ACT) Z	1
3	351666	HITCH LEVEL SHIM	4
	351665	HITCH LEVEL SHIM KIT	1

Place shims under anchor as shown as required. Secure with bolt and lock washer, one anchor only.

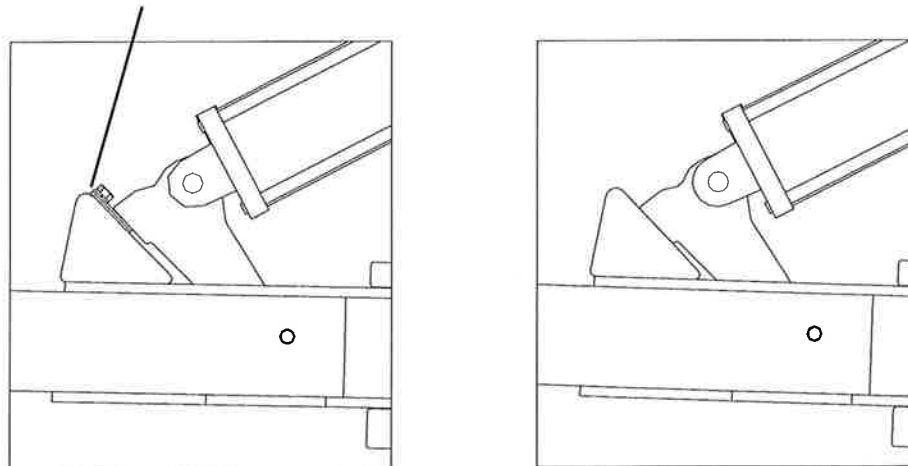

700331S2 4/3/12



**THIS PAGE INTENTIONALLY LEFT BLANK**

# LEFT INNER WING ASSEMBLY- 15.2 M (50 FT) UNIT

SEE PG 82-85 FOR WING  
REST LOCATION

**HDW KIT  
79973-4**

DO NOT OVERTIGHTEN, BOLT  
MUST MOVE IN ANCHOR SLOT

NOTE: CRITICAL ROLLER  
233181 REQUIRED

CYLINDER PINS ARE PROVIDED IN ALL  
LIFT CYLINDER BOXES

SHANK MOUNTING  
PLATE LOCATION

DO NOT OVERTIGHTEN  
88487 BOLTS WHICH  
CAN CRACK 34132  
BEARING CAPS

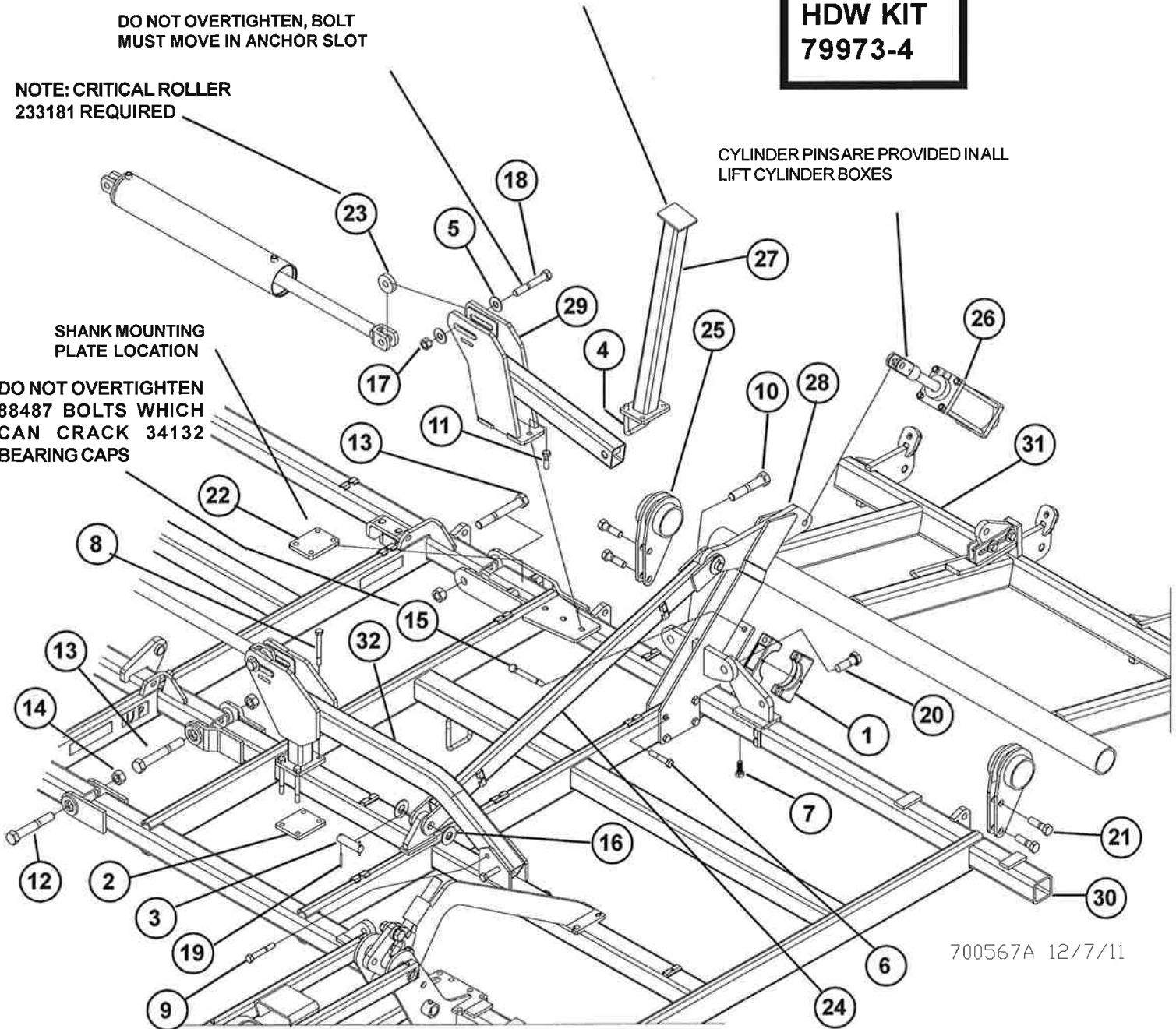

700567A 12/7/11

# LEFT INNER WING ASSEMBLY- 15.2 M (50 FT) UNIT

ITEM	PART NO.	DESCRIPTION	QTY
1	34132	AXLE CLAMP ASSEMBLY (RED)	4
2	62271	FRAME PLATE (RED)	1
3	67854	HEADLESS PIN(2) 1-1/4X4-1/2	2
4	88145	BLT-U 5/8-11NCX4X5-1/4 Z	2
5	88196	WSHR FLAT 1(1-1/16X2-1/2ACT) Z	4
6	88272	BLT HEX 3/4-10NCX4 5Z	4
7	88290	BLT HEX 3/4-10NCX2 8YZ	2
8	88295	BLT HEX 5/8-11NCX6 5Z	4
9	88305	BLT HEX 3/4-10NCX5 5Z	2
10	88349	BLT HEX 1-1/4-7NCX6-1/2 5Z	1
11	88404	BLT HEX 3/4-10NCX2-1/2 5Z	3
12	88427	BLT HEX 1-1/4-7NCX8 5Z	1
13	88428	BLT HEX 1-1/4-7NCX9 5Z	2
14	88430	NUT 2POSLK 1-1/4-7NC 5Z	3
15	88487	BLT HEX 3/4-10NCX8-1/2 5Z	6
16	88602	WSHR FLAT 1-1/4(1-3/8X3ACT) Z	4
17	88658	NUT TOP LK 1-8NC 5Z	2
18	88666	BLT HEX 1-8NCX6-1/2 5Z	2
19	88767	PIN ROLL 1/4DIA X2-1/2 Z	4
20	89029	BLT HEX 1-1/4-7NC X 4 5Z	1
21	89371	BLT HEX 1-8NCX3-1/2 8YZ	4
22	221196	MOUNT PLATE - PRE 2013 ONLY	1
23	233181	LINK DONUT (ZINC)	2
24	240572	LIFT MAST TUBE	1
25	241513	CENTER PACKER HANGER	2
26	241622	HYD CYL 4-1/2X8 SEQ	1
27	241633	OUTER WING REST - ATD	1
28	244869	SHORT INNER WING PACKER TOWER	1
29	245079	REAR FOLD MAST 5015 ATD	1
30	245664	LEFT INNER WING 5015 ATD	1
31	245673	LEFT INNER PACKER GANG 5015 ATD	1
32	245676	FRONT WING ANCHOR 5015 ATD	1

UNLESS SPECIFIED, ALL HARDWARE IS SECURED WITH MATCHING LOCK NUTS.  
 QUANTITIES MAY VARY BY MODEL CONFIGURATION.

# RIGHT INNER WING ASSEMBLY - 15.2 M (50 FT) UNIT

**HDW KIT  
79973-4**

SEE PG 82-85 FOR WING  
REST LOCATION

DO NOT OVERTIGHTEN 88487  
BOLTS WHICH CAN CRACK  
34132 BEARING CAPS

SEE PG 82-85 FOR WING  
REST LOCATION

DO NOT OVERTIGHTEN,  
BOLT MUST MOVE IN  
ANCHOR SLOT

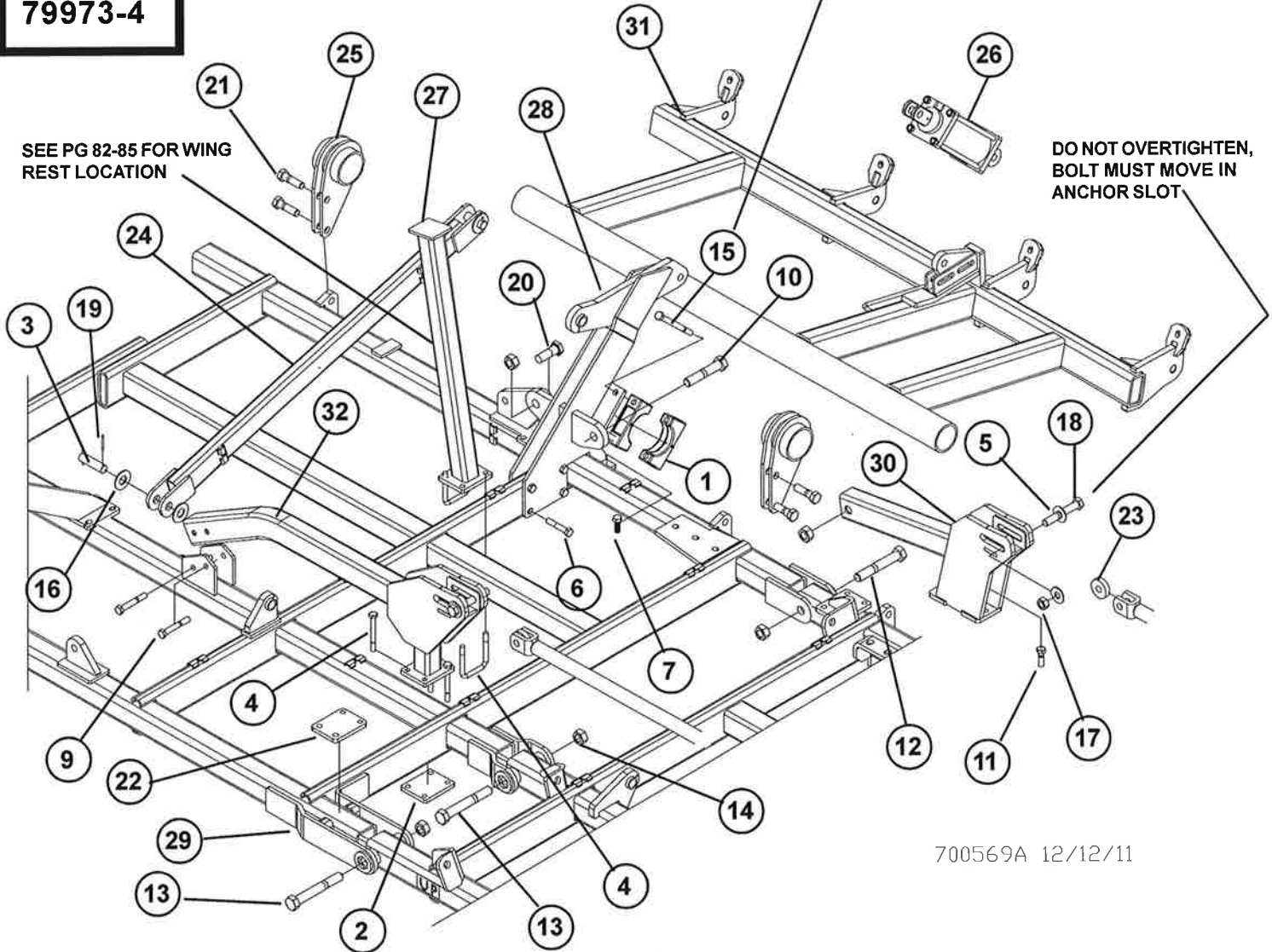

700569A 12/12/11

# **RIGHT INNER WING ASSEMBLY - 15.2 M (50 FT) UNIT**

<b>ITEM</b>	<b>PART NO.</b>	<b>DESCRIPTION</b>	<b>QTY</b>
1	34132	AXLE CLAMP ASSEMBLY (RED)	4
2	62271	FRAME PLATE (RED)	1
3	67854	HEADLESS PIN(2) 1-1/4X4-1/2	2
4	88145	BLT-U 5/8-11NCX4X5-1/4 Z	2
5	88196	WSHR FLAT 1(1-1/16X2-1/2ACT) Z	4
6	88272	BLT HEX 3/4-10NCX4 5Z	4
7	88290	BLT HEX 3/4-10NCX2 8YZ	2
8	88295	BLT HEX 5/8-11NCX6 5Z	4
9	88305	BLT HEX 3/4-10NCX5 5Z	2
10	88349	BLT HEX 1-1/4-7NCX6-1/2 5Z	1
11	88404	BLT HEX 3/4-10NCX2-1/2 5Z	3
12	88427	BLT HEX 1-1/4-7NCX8 5Z	1
13	88428	BLT HEX 1-1/4-7NCX9 5Z	2
14	88430	NUT 2POSLK 1-1/4-7NC 5Z	5
15	88487	BLT HEX 3/4-10NCX8-1/2 5Z	4
16	88602	WSHR FLAT 1-1/4(1-3/8X3ACT) Z	4
17	88658	NUT TOP LK 1-8NC 5Z	2
18	88666	BLT HEX 1-8NCX6-1/2 5Z	2
19	88767	PIN ROLL 1/4DIAX2-1/2 Z	4
20	89029	BLT HEX 1-1/4-7NC X 4 5Z	1
21	89371	BLT HEX 1-8NCX3-1/2 8YZ	4
22	221196	MOUNT PLATE - PRE 2013 ONLY	1
23	233181	LINK DONUT (ZINC)	2
24	240572	LIFT MAST TUBE	1
25	241513	CENTER PACKER HANGER	2
26	241622	HYD CYL 4-1/2X8 SEQ	1
27	241633	OUTER WING REST - ATD	1
28	244869	SHORT INNER WING PACKER TOWER	1
29	245073	RIGHT INNER WING 5015 ATD	1
30	245079	REAR FOLD MAST 5015 ATD	1
31	245674	RIGHT INNER PACKER GANG 5015 ATD	1
32	245676	FRONT WING ANCHOR 5015 ATD	1

**UNLESS SPECIFIED, ALL HARDWARE IS SECURED WITH MATCHING LOCK NUTS.  
QUANTITIES MAY VARY BY MODEL CONFIGURATION.**

# LEFT INNER WING ASSEMBLY- 18.3M (60 FT) UNIT

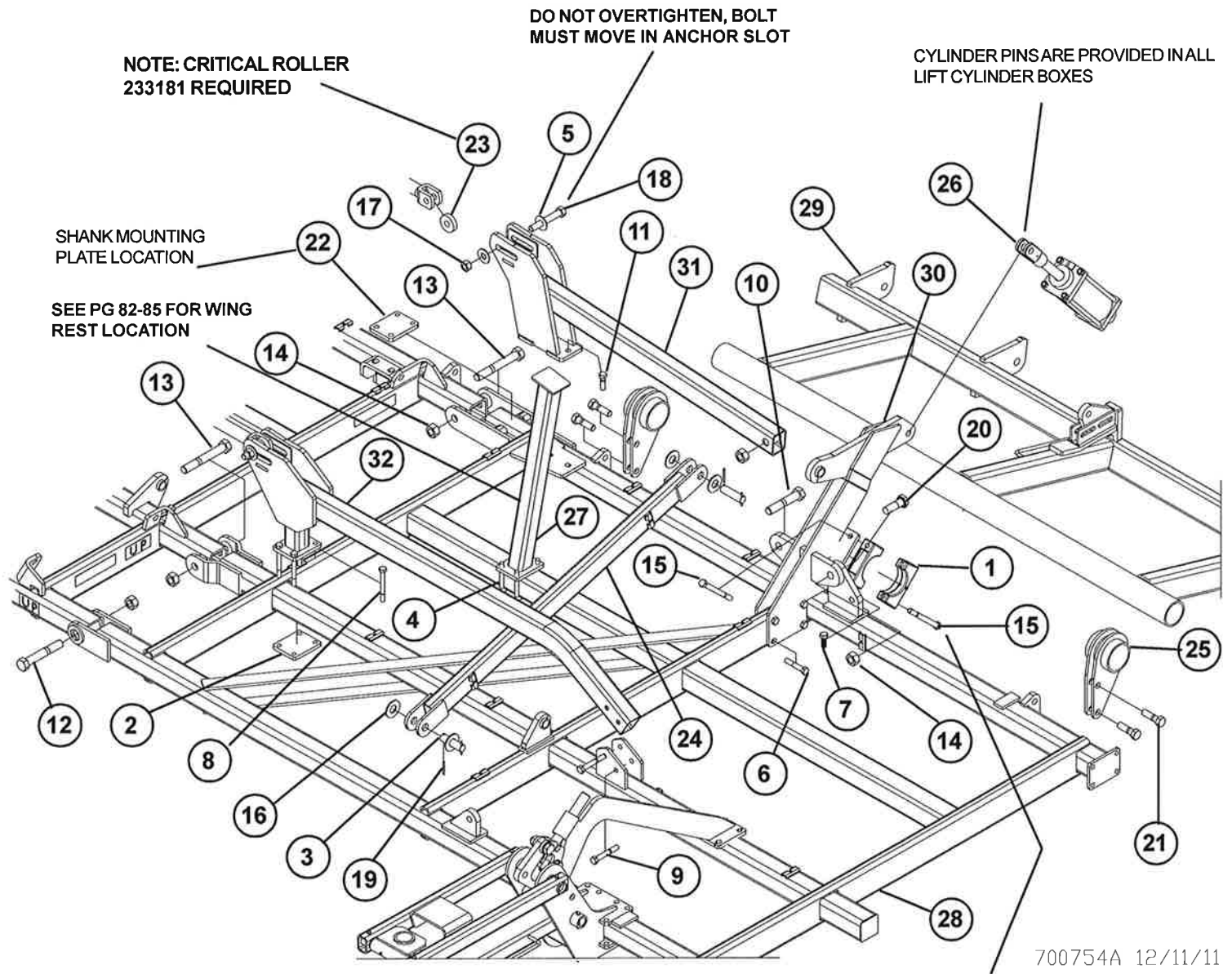

NOTE: CRITICAL ROLLER  
233181 REQUIRED

DO NOT OVERTIGHTEN, BOLT  
MUST MOVE IN ANCHOR SLOT

CYLINDER PINS ARE PROVIDED IN ALL  
LIFT CYLINDER BOXES

SHANK MOUNTING  
PLATE LOCATION

SEE PG 82-85 FOR WING  
REST LOCATION

700754A 12/11/11

DO NOT OVERTIGHTEN 88487 BOLTS  
WHICH CAN CRACK 34132 BEARING  
CAPS

**HDW KIT  
79973-4**

# LEFT INNER WING ASSEMBLY- 18.3M (60 FT) UNIT

ITEM	PART NO.	DESCRIPTION	QTY
1	34132	AXLE CLAMP ASSEMBLY (RED)	4
2	62271	FRAME PLATE (RED)	1
3	67854	HEADLESS PIN(2) 1-1/4X4-1/2	2
4	88145	BLT-U 5/8-11NCX4X5-1/4 Z	2
5	88196	WSHR FLAT 1(1-1/16X2-1/2ACT) Z	4
6	88272	BLT HEX 3/4-10NCX4 5Z	4
7	88290	BLT HEX 3/4-10NCX2 8YZ	2
8	88295	BLT HEX 5/8-11NCX6 5Z	4
9	88305	BLT HEX 3/4-10NCX5 5Z	2
10	88349	BLT HEX 1-1/4-7NCX6-1/2 5Z	1
11	88404	BLT HEX 3/4-10NCX2-1/2 5Z	3
12	88427	BLT HEX 1-1/4-7NCX8 5Z	1
13	88428	BLT HEX 1-1/4-7NCX9 5Z	2
14	88430	NUT 2POSLK 1-1/4-7NC 5Z	5
15	88487	BLT HEX 3/4-10NCX8-1/2 5Z	4
16	88602	WSHR FLAT 1-1/4(1-3/8X3ACT) Z	4
17	88658	NUT TOP LK 1-8NC 5Z	6
18	88666	BLT HEX 1-8NCX6-1/2 5Z	2
19	88767	PIN ROLL 1/4DIAX2-1/2 Z	4
20	89029	BLT HEX 1-1/4-7NC X 4 5Z	1
21	89371	BLT HEX 1-8NCX3-1/2 8YZ	4
22	221196	MOUNT PLATE - PRE 2013 ONLY	1
23	233181	LINK DONUT (ZINC)	2
24	240572	LIFT MAST TUBE	1
25	241513	CENTER PACKER HANGER	2
26	241622	HYD CYL 4-1/2X8 SEQ	1
27	241633	OUTER WING REST - ATD	1
28	244833	LEFT INNER WING - 6015 ATD	1
29	244859	INNER WING PACKER MOUNT 6015 ATD	1
30	244869	SHORT INNER WING PACKER TOWER	1
31	244874	REAR FOLD MAST	1
32	244877	FRONT WING ANCHOR	1

UNLESS SPECIFIED, ALL HARDWARE IS SECURED WITH MATCHING LOCK NUTS.  
 QUANTITIES MAY VARY BY MODEL CONFIGURATION.

# RIGHT INNER WING ASSEMBLY - 18.3 M (60 FT) UNIT

DO NOT OVERTIGHTEN  
88487 BOLTS WHICH CAN  
CRACK 34132 BEARING  
CAPS

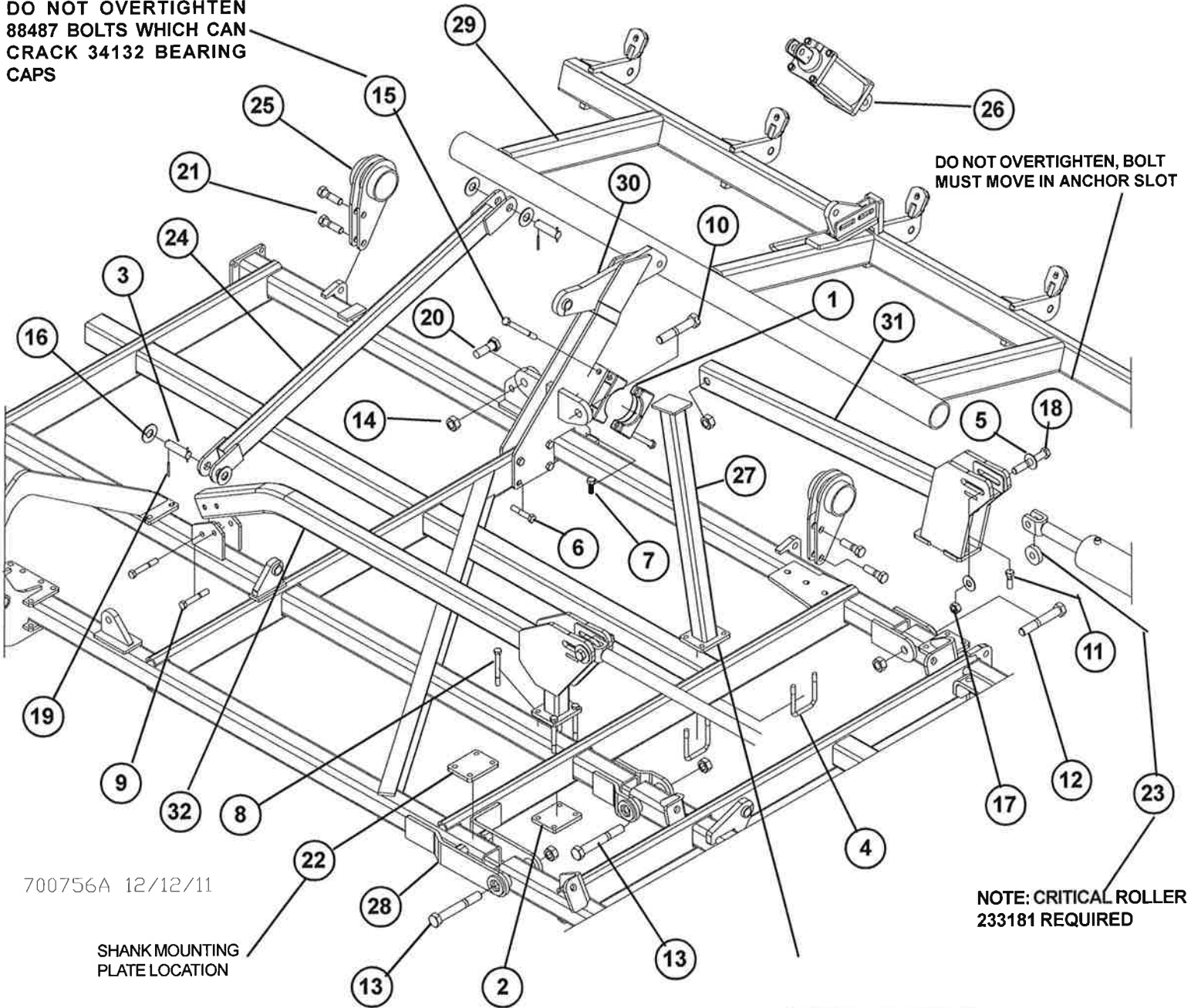

**HDW KIT  
79973-4**



# RIGHT INNER WING ASSEMBLY - 18.3 M (60 FT) UNIT

ITEM	PART NO.	DESCRIPTION	QTY
1	34132	AXLE CLAMP ASSEMBLY (RED)	4
2	62271	FRAME PLATE (RED)	1
3	67854	HEADLESS PIN(2) 1-1/4X4-1/2	2
4	88145	BLT-U 5/8-11NCX4X5-1/4 Z	2
5	88196	WSHR FLAT 1(1-1/16X2-1/2ACT) Z	4
6	88272	BLT HEX 3/4-10NCX4 5Z	4
7	88290	BLT HEX 3/4-10NCX2 8YZ	2
8	88295	BLT HEX 5/8-11NCX6 5Z	4
9	88305	BLT HEX 3/4-10NCX5 5Z	2
10	88349	BLT HEX 1-1/4-7NCX6-1/2 5Z	1
11	88404	BLT HEX 3/4-10NCX2-1/2 5Z	3
12	88427	BLT HEX 1-1/4-7NCX8 5Z	1
13	88428	BLT HEX 1-1/4-7NCX9 5Z	2
14	88430	NUT 2POSLK 1-1/4-7NC 5Z	5
15	88487	BLT HEX 3/4-10NCX8-1/2 5Z	4
16	88602	WSHR FLAT 1-1/4(1-3/8X3ACT) Z	4
17	88658	NUT TOP LK 1-8NC 5Z	6
18	88666	BLT HEX 1-8NCX6-1/2 5Z	2
19	88767	PIN ROLL 1/4DIAX2-1/2 Z	4
20	89029	BLT HEX 1-1/4-7NC X 4 5Z	1
21	89371	BLT HEX 1-8NCX3-1/2 8YZ	4
22	221196	MOUNT PLATE - PRE 2013 ONLY	1
23	233181	LINK DONUT (ZINC)	2
24	240572	LIFT MAST TUBE	1
25	241513	CENTER PACKER HANGER	2
26	241622	HYD CYL 4-1/2X8 SEQ	1
27	241633	OUTER WING REST - ATD	1
28	244835	RIGHT INNER WING - 6015 ATD	1
29	244859	INNER WING PACKER MOUNT 6015 ATD	1
30	244869	SHORT INNER WING PACKER TOWER	1
31	244874	REAR FOLD MAST	1
32	244877	FRONT WING ANCHOR	1

UNLESS SPECIFIED, ALL HARDWARE IS SECURED WITH MATCHING LOCK NUTS.  
 QUANTITIES MAY VARY BY MODEL CONFIGURATION.

# OUTER WING HINGE ASSEMBLY- 15.2 M (50 FT) UNIT

**HDW KIT  
79973-5**

USE 5/8X6 BOLTS THAT ARE SUPPLIED WITH THE SHANK IN REAR HOLES TO MOUNT 241707. USE THE 3/4X6NC BOLTS PROVIDED IN HARDWARE KIT IN FRONT HOLES ONLY. DO NOT USE 3/4X6-1/2NF SHANK BOLTS IN FRONT HOLES.

USE FLAT WASHERS TO CENTER CYLINDER BETWEEN LINKS IF REQUIRED

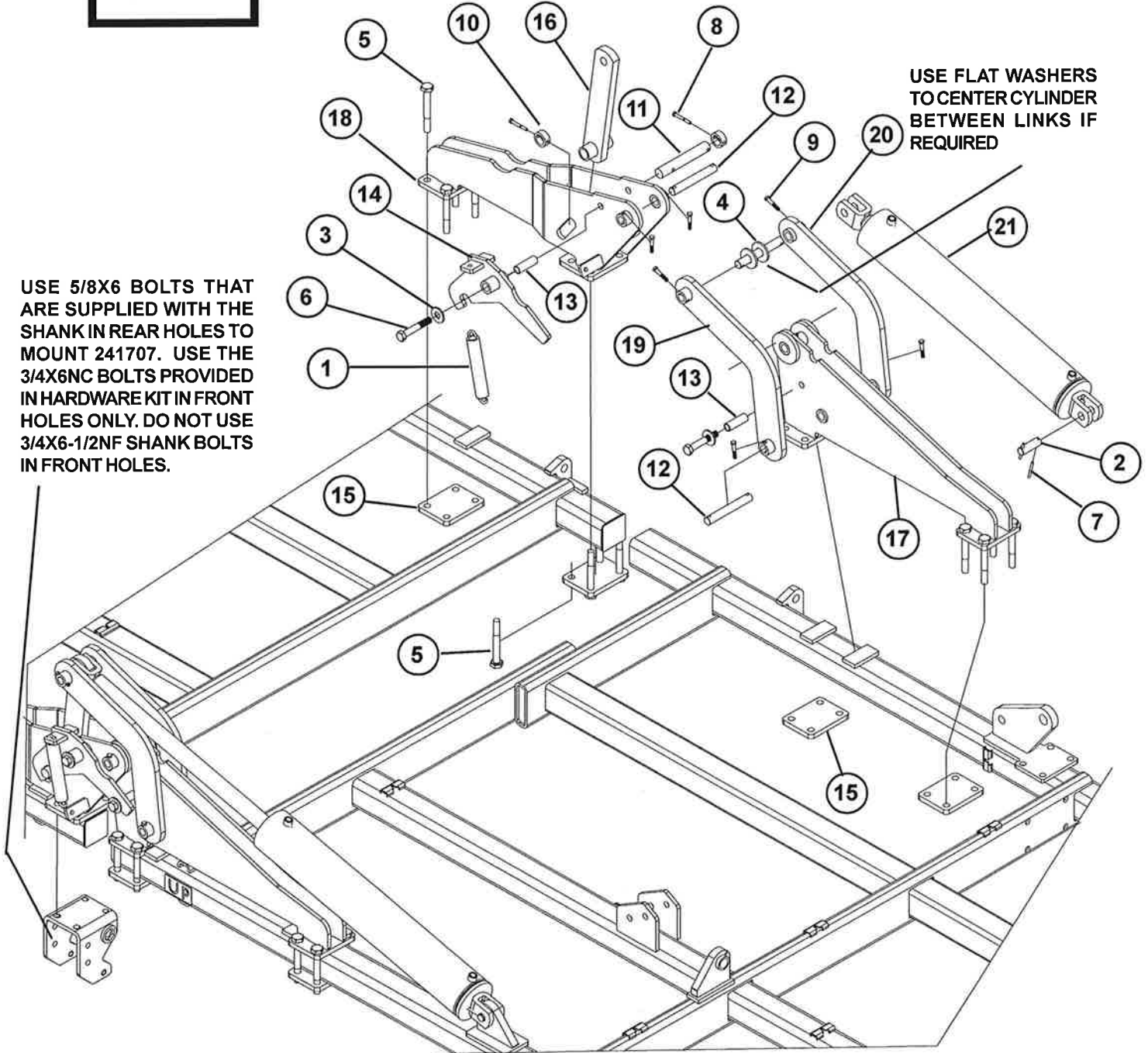

700761A 12/12/11

**SEE MOUNTING PAGES FOR  
SHANK LOCATIONS**

# **OUTER WING HINGE ASSEMBLY- 15.2 M (50 FT) UNIT**

<b>ITEM</b>	<b>PART NO.</b>	<b>DESCRIPTION</b>	<b>QTY</b>
1	25863	SPRING	2
2	42473	HEADLESS PIN (H) (2) 1X2-3/8	2
3	88131	WSHR FLAT 3/4(13/16X2ACT) Z	4
4	88196	WSHR FLAT 1(1-1/16X2-1/2ACT) Z	8
5	88293	BLT HEX 3/4-10NCX6 5Z	24
6	88421	BLT HEX 3/4-10NCX4-1/2 5Z	4
7	88767	PIN ROLL 1/4DIA X2-1/2 Z	4
8	89004	BLT HEX 5/16-18NCX2-1/2 5Z	4
9	89011	BLT HEX 3/8-16NC X 2 5Z	12
10	233589	PIN BUSHING (ZINC)	4
11	233900	LOCK PIN	2
12	236349	HINGE PIN (ZINC)	6
13	236391	PIVOT TUBE (ZINC)	4
14	236394	OUTER WING LATCH BRACKET	2
15	239045	HINGE TIE PLATE - PAINTED	6
16	240544	OUTER FOLD LINK	2
17	241705	INNER WING HINGE	2
18	241707	OUTER HINGE PIVOT	2
19	243017	OUTER FOLD LINK - FRONT	2
20	243018	OUTER FOLD LINK - REAR	2
21	20966F	HYD CYL 5X30 FGS #A519CY07	2

**UNLESS SPECIFIED, ALL HARDWARE IS SECURED WITH MATCHING LOCK NUTS.  
QUANTITIES MAY VARY BY MODEL CONFIGURATION.**

# OUTER WING HINGE ASSEMBLY- 18.3 M (60 FT) UNIT

RIGHT WING SHOWN

**HDW KIT  
79973-6**

USE FLAT WASHERS  
TO CENTER CYLINDER  
BETWEEN LINKS IF  
REQUIRED

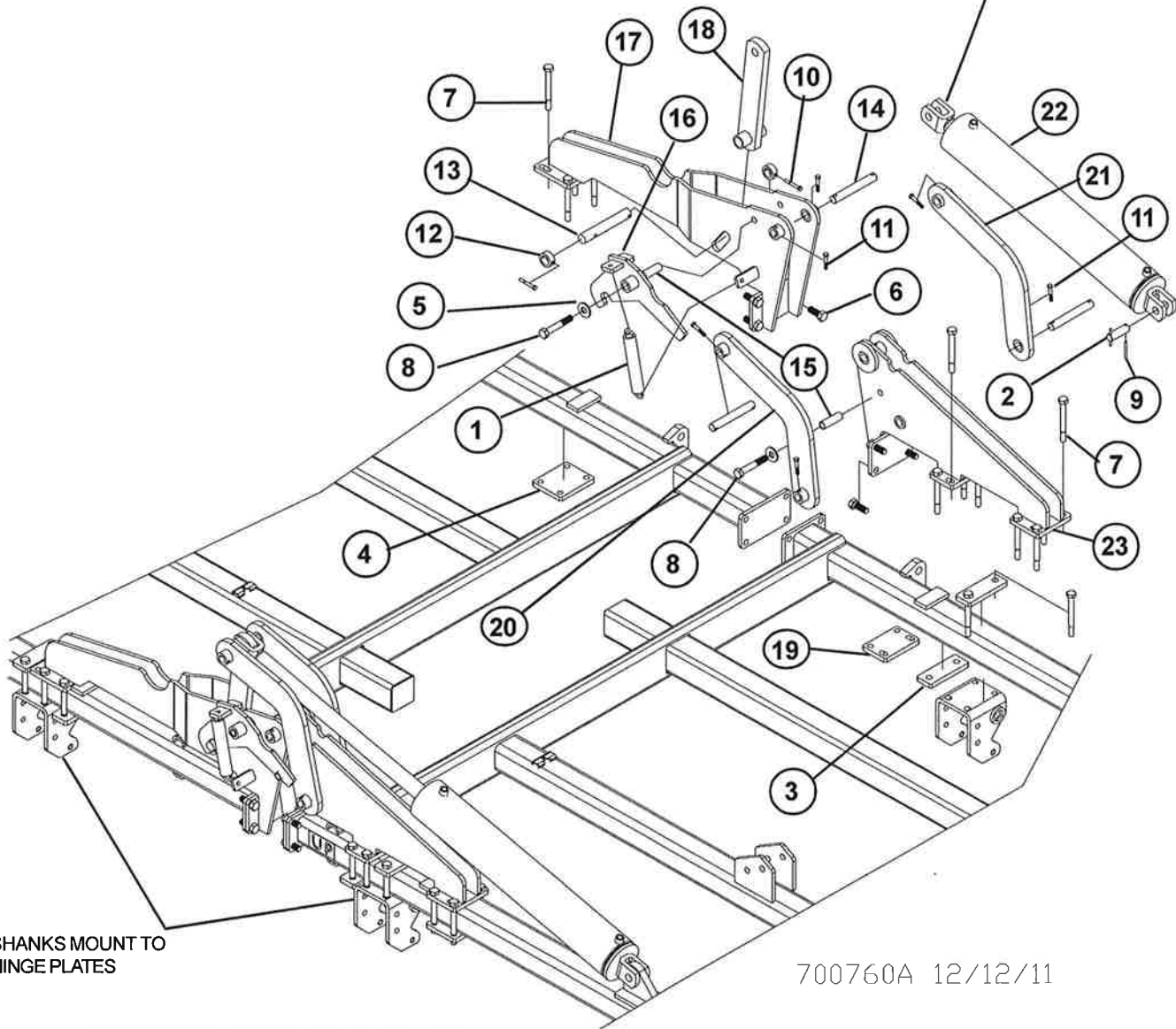

SHANKS MOUNT TO  
HINGE PLATES

700760A 12/12/11

**SEE MOUNTING PAGES FOR  
SHANK LOCATIONS**

**UNLESS SPECIFIED, ALL HARDWARE IS SECURED WITH MATCHING LOCK NUTS.  
QUANTITIES MAY VARY BY MODEL CONFIGURATION.**

# **OUTER WING HINGE ASSEMBLY- 18.3 M (60 FT) UNIT**

<b>ITEM</b>	<b>PART NO.</b>	<b>DESCRIPTION</b>	<b>QTY</b>
1	25863	SPRING	2
2	42473	HEADLESS PIN (H) (2) 1X2-3/8	2
3	53419	STRAP (RED)	6
4	62271	FRAME PLATE (RED)	2
5	88131	WSHR FLAT 3/4(13/16X2ACT) Z	2
6	88290	BLT HEX 3/4-10NCX2 8YZ	16
7	88295	BLT HEX 5/8-11NCX6 5Z	30
8	88421	BLT HEX 3/4-10NCX4-1/2 5Z	4
9	88767	PIN ROLL 1/4DIA X 2-1/2 Z	4
10	89004	BLT HEX 5/16-18NCX2-1/2 5Z	4
11	89011	BLT HEX 3/8-16NC X 2 5Z	12
12	233589	PIN BUSHING (ZINC)	4
13	233900	LOCK PIN	2
14	236349	HINGE PIN (ZINC)	6
15	236391	PIVOT TUBE (ZINC)	4
16	236394	OUTER WING LATCH BRACKET	2
17	237941	OUTER WING HINGE - ATD	2
18	240544	OUTER FOLD LINK	2
19	241544	FRAME PLATE - PAINTED (241505)	1
20	243017	OUTER FOLD LINK - FRONT	2
21	243018	OUTER FOLD LINK - REAR	2
22	20966F	HYD CYL 5X30 FGS #A519CY07	2
23	237794D1	INNER WING HINGE	2

**UNLESS SPECIFIED, ALL HARDWARE IS SECURED WITH MATCHING LOCK NUTS.  
QUANTITIES MAY VARY BY MODEL CONFIGURATION.**

# LEFT OUTER WING ASSEMBLY - 15.2 M (50 FT) UNIT

**HDW KIT  
79973-7**

CYLINDER PINS ARE PROVIDED IN ALL  
LIFT CYLINDER BOXES

**DO NOT OVERTIGHTEN 88487  
BOLTS WHICH CAN CRACK  
34132 BEARING CAPS**

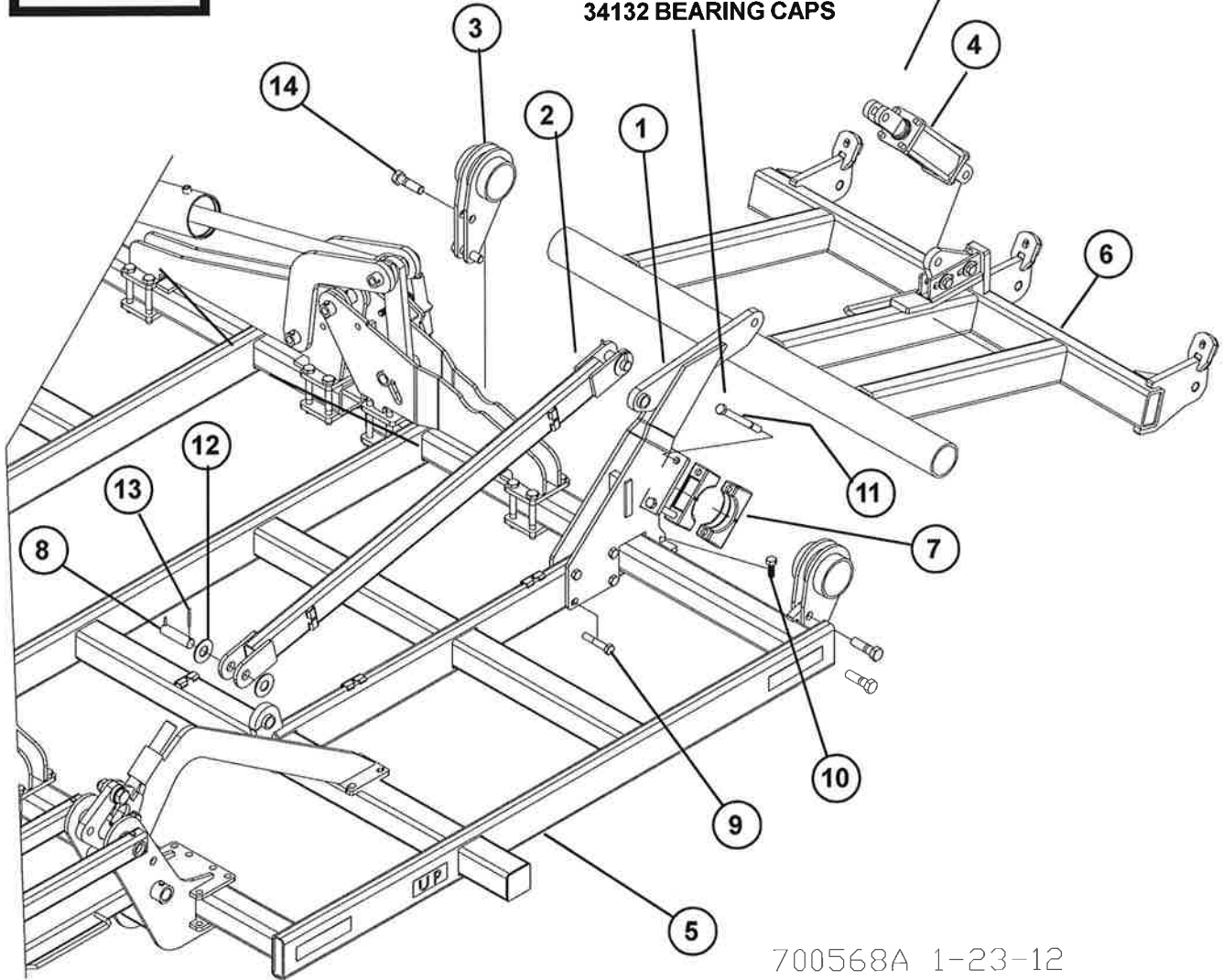

700568A 1-23-12

**UNLESS SPECIFIED, ALL HARDWARE IS SECURED WITH MATCHING LOCK NUTS.  
QUANTITIES MAY VARY BY MODEL CONFIGURATION.**

# **LEFT OUTER WING ASSEMBLY - 15.2 M (50 FT) UNIT**

<b>ITEM</b>	<b>PART NO.</b>	<b>DESCRIPTION</b>	<b>QTY</b>
1	235761	PACKER LIFT BRACKET	1
2	240572	LIFT MAST TUBE	1
3	241513	CENTER PACKER HANGER	2
4	241665	HYD CYL 3-1/2X8 WITH SPACER	1
5	245667	LEFT OUTER WING 5015 ATD	1
6	245672	OUTER PACKER GANG 5015 ATD	1
7	34132	AXLE CLAMP ASSEMBLY (RED)	4
8	67854	HEADLESS PIN(2) 1-1/4X4-1/2	2
9	88272	BLT HEX 3/4-10NCX4 5Z	4
10	88290	BLT HEX 3/4-10NCX2 8YZ	2
11	88487	BLT HEX 3/4-10NCX8-1/2 5Z	4
12	88602	WSHR FLAT 1-1/4(1-3/8X3ACT) Z	4
13	88767	PIN ROLL 1/4DIA X2-1/2 Z	4
14	89371	BLT HEX 1-8NCX3-1/2 8YZ	4

**UNLESS SPECIFIED, ALL HARDWARE IS SECURED WITH MATCHING LOCK NUTS.  
QUANTITIES MAY VARY BY MODEL CONFIGURATION.**

# RIGHT OUTER WING ASSEMBLY - 15.2 M (50 FT) UNIT

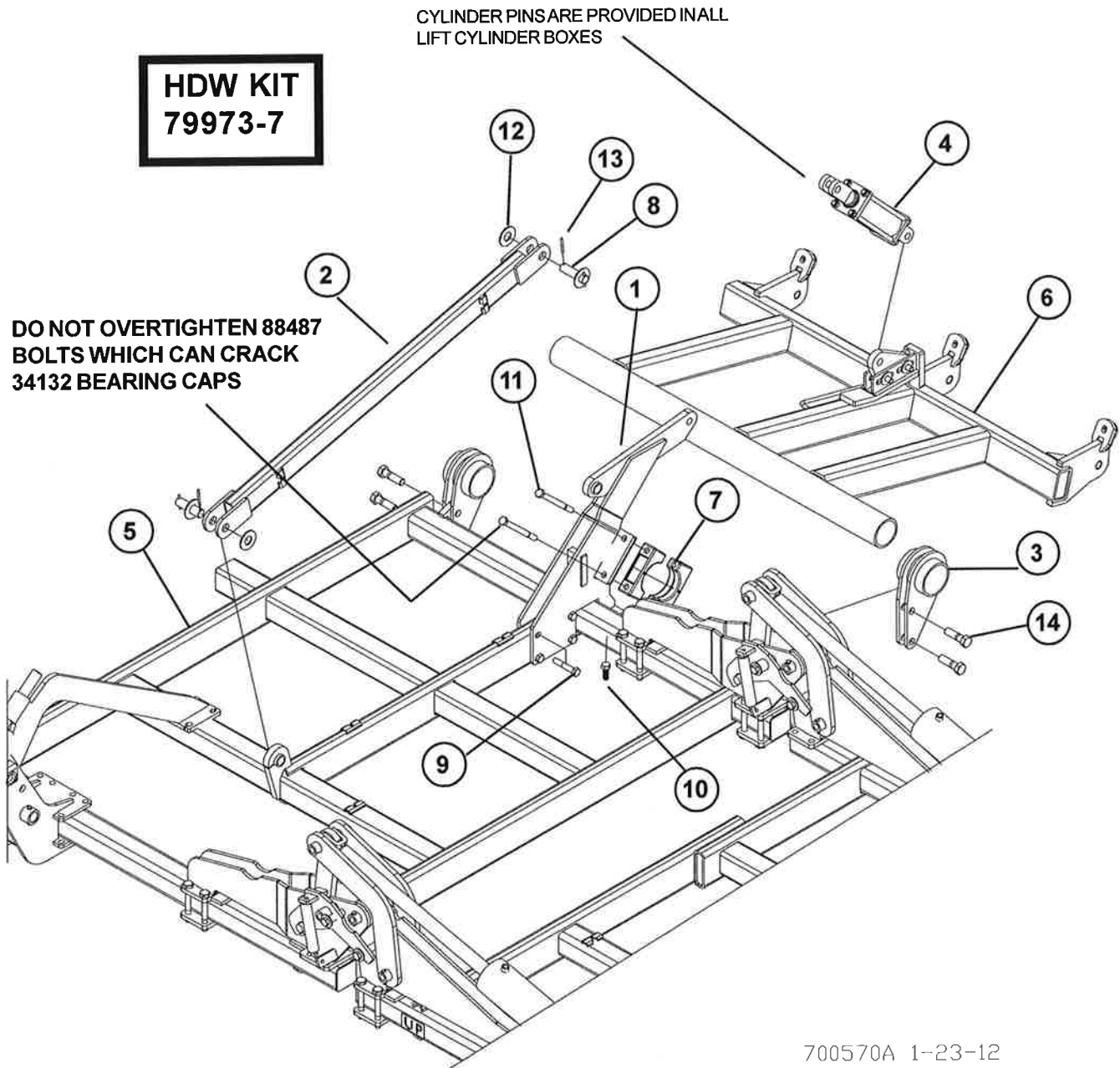

**UNLESS SPECIFIED, ALL HARDWARE IS SECURED WITH MATCHING LOCK NUTS.  
QUANTITIES MAY VARY BY MODEL CONFIGURATION.**



# **RIGHT OUTER WING ASSEMBLY - 15.2 M (50 FT) UNIT**

<b>ITEM</b>	<b>PART NO.</b>	<b>DESCRIPTION</b>	<b>QTY</b>
1	235761	PACKER LIFT BRACKET	1
2	240572	LIFT MAST TUBE	1
3	241513	CENTER PACKER HANGER	2
4	241665	HYD CYL 3-1/2X8 WITH SPACER	1
5	245072	RIGHT OUTER WING 5015 ATD	1
6	245672	OUTER PACKER GANG 5015 ATD	1
7	34132	AXLE CLAMP ASSEMBLY (RED)	4
8	67854	HEADLESS PIN(2) 1-1/4X4-1/2	2
9	88272	BLT HEX 3/4-10NCX4 5Z	4
10	88290	BLT HEX 3/4-10NCX2 8YZ	2
11	88487	BLT HEX 3/4-10NCX8-1/2 5Z	4
12	88602	WSHR FLAT 1-1/4(1-3/8X3ACT) Z	4
13	88767	PIN ROLL 1/4DIAX2-1/2 Z	4
14	89371	BLT HEX 1-8NCX3-1/2 8YZ	4

**UNLESS SPECIFIED, ALL HARDWARE IS SECURED WITH MATCHING LOCK NUTS.  
QUANTITIES MAY VARY BY MODEL CONFIGURATION.**

# LEFT OUTER WING ASSEMBLY - 18.3 M (60 FT) UNIT

**HDW KIT  
79973-7**

**DO NOT OVERTIGHTEN 88487  
BOLTS WHICH CAN CRACK  
34132 BEARING CAPS**

CYLINDER PINS ARE PROVIDED  
IN ALL LIFT CYLINDER BOXES

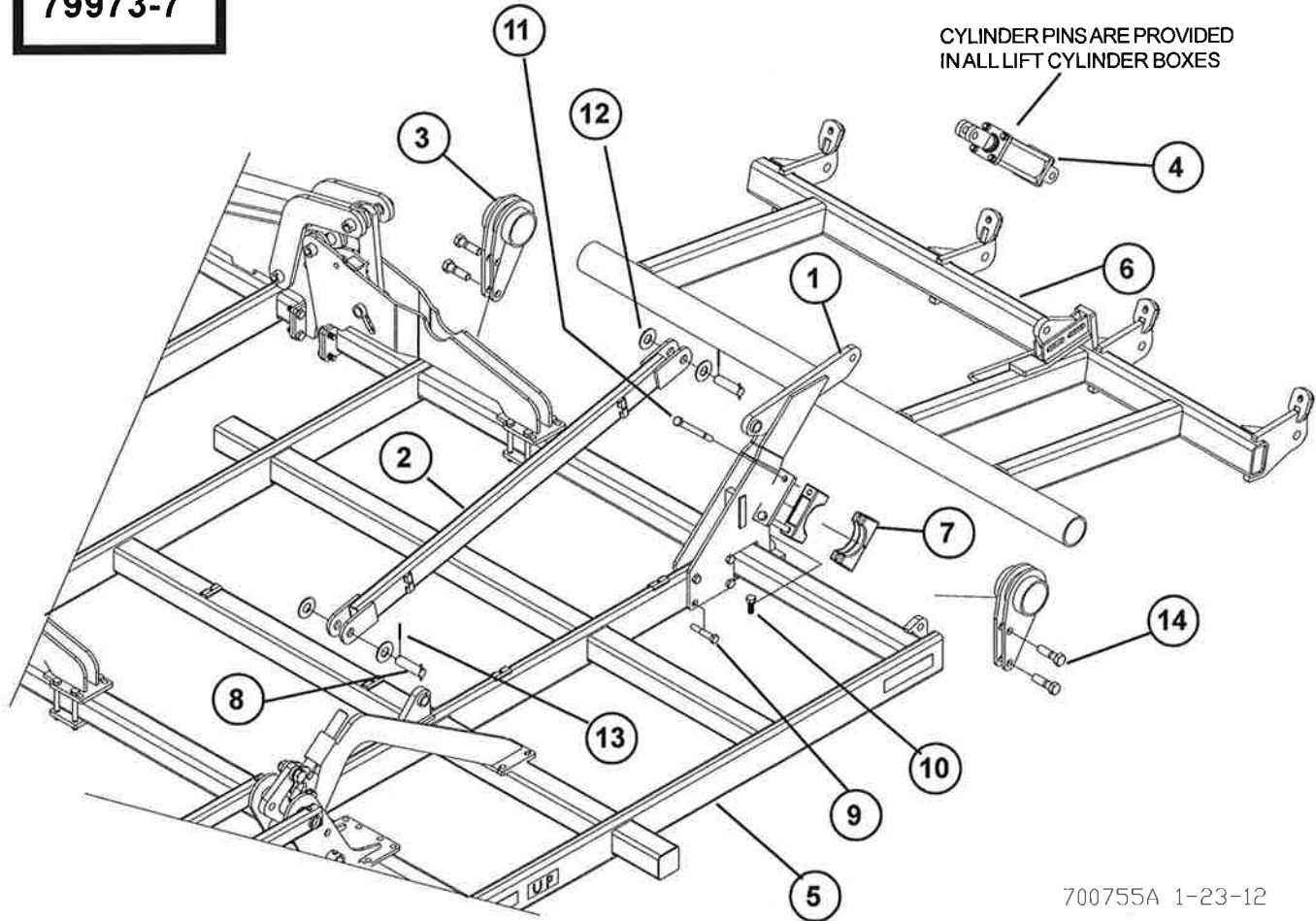

700755A 1-23-12

## **LEFT OUTER WING ASSEMBLY - 18.3 M (60 FT) UNIT**

<b>ITEM</b>	<b>PART NO.</b>	<b>DESCRIPTION</b>	<b>QTY</b>
1	235761	PACKER LIFT BRACKET	1
2	240572	LIFT MAST TUBE	1
3	241513	CENTER PACKER HANGER	2
4	241665	HYD CYL 3-1/2X8 WITH SPACER	1
5	244834	LEFT OUTER WING - 6015 ATD	1
6	244858	LEFT OUTER WNG PACKER MNT 6015 ATD	1
7	34132	AXLE CLAMP ASSEMBLY (RED)	4
8	67854	HEADLESS PIN(2) 1-1/4X4-1/2	2
9	88272	BLT HEX 3/4-10NCX4 5Z	4
10	88290	BLT HEX 3/4-10NCX2 8YZ	2
11	88487	BLT HEX 3/4-10NCX8-1/2 5Z	4
12	88602	WSHR FLAT 1-1/4(1-3/8X3ACT) Z	4
13	88767	PIN ROLL 1/4DIAX2-1/2 Z	4
14	89371	BLT HEX 1-8NCX3-1/2 8YZ	4

**UNLESS SPECIFIED, ALL HARDWARE IS SECURED WITH MATCHING LOCK NUTS.  
QUANTITIES MAY VARY BY MODEL CONFIGURATION.**

# RIGHT OUTER WING ASSEMBLY - 18.3 M (60 FT) UNIT

**HDW KIT  
79973-7**

CYLINDER PINS ARE PROVIDED  
IN ALL LIFT CYLINDER BOXES

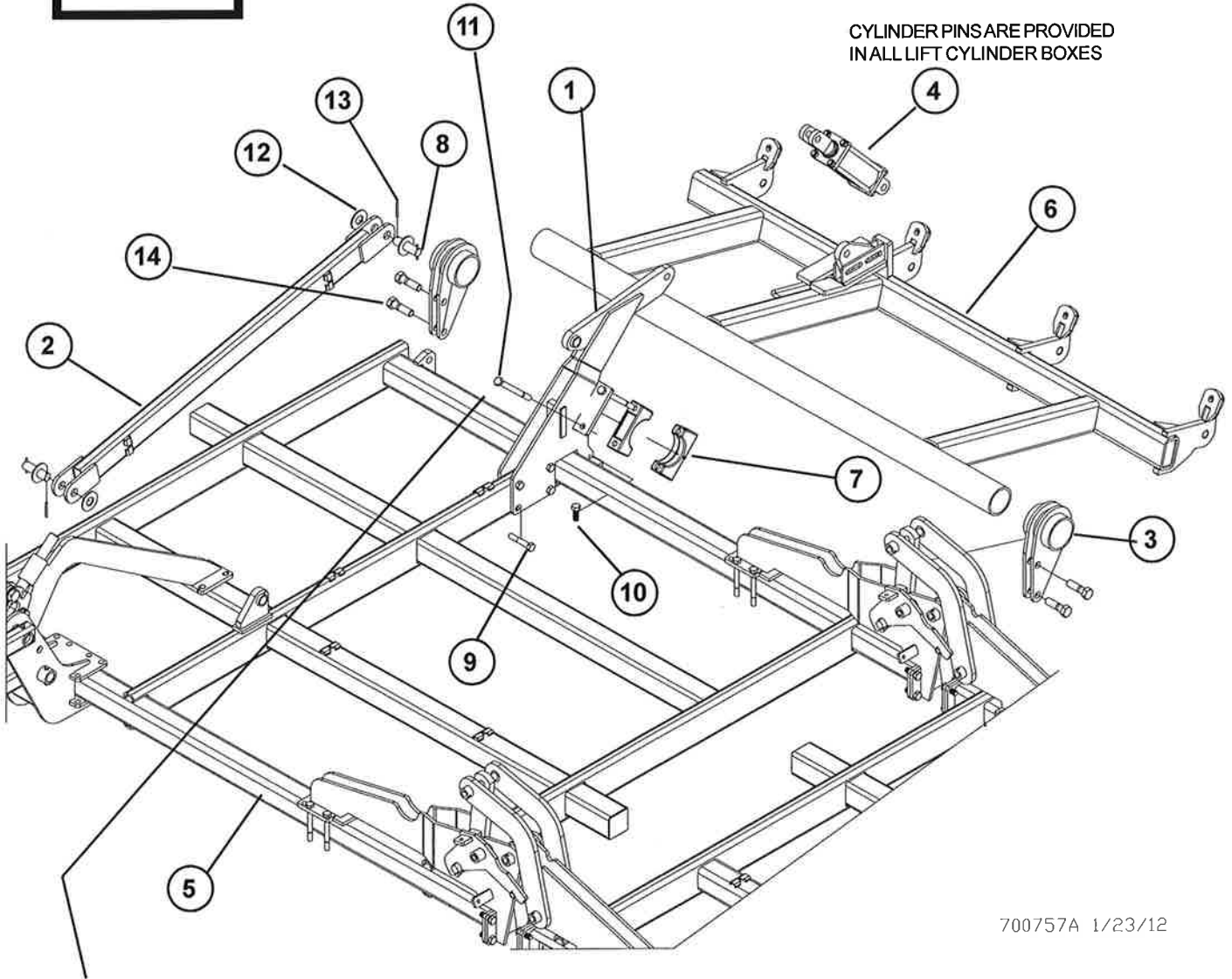

700757A 1/23/12

**DO NOT OVERTIGHTEN 88487 BOLTS WHICH  
CAN CRACK 34132 BEARING CAPS**

# **RIGHT OUTER WING ASSEMBLY - 18.3 M (60 FT) UNIT**

<b>ITEM</b>	<b>PART NO.</b>	<b>DESCRIPTION</b>	<b>QTY</b>
1	235761	PACKER LIFT BRACKET	1
2	240572	LIFT MAST TUBE	1
3	241513	CENTER PACKER HANGER	2
4	241665	HYD CYL 3-1/2X8 WITH SPACER	1
5	244836	RIGHT OUTER WING - 6015 ATD	1
6	244878	RIGHT OUTER WING PACKER 6015 ATD	1
7	34132	AXLE CLAMP ASSEMBLY (RED)	4
8	67854	HEADLESS PIN(2) 1-1/4X4-1/2	2
9	88272	BLT HEX 3/4-10NCX4 5Z	4
10	88290	BLT HEX 3/4-10NCX2 8YZ	2
11	88487	BLT HEX 3/4-10NCX8-1/2 5Z	4
12	88602	WSHR FLAT 1-1/4(1-3/8X3ACT) Z	4
13	88767	PIN ROLL 1/4DIAX2-1/2 Z	4
14	89371	BLT HEX 1-8NCX3-1/2 8YZ	4

**UNLESS SPECIFIED, ALL HARDWARE IS SECURED WITH MATCHING LOCK NUTS.  
QUANTITIES MAY VARY BY MODEL CONFIGURATION.**

# WING LIFT WHEEL ASSEMBLY

HDW KIT  
79973-8

NOTE: FRONT LIFT WHEEL  
ASSEMBLIES ARE ASSEMBLED AT  
THE FACTORY

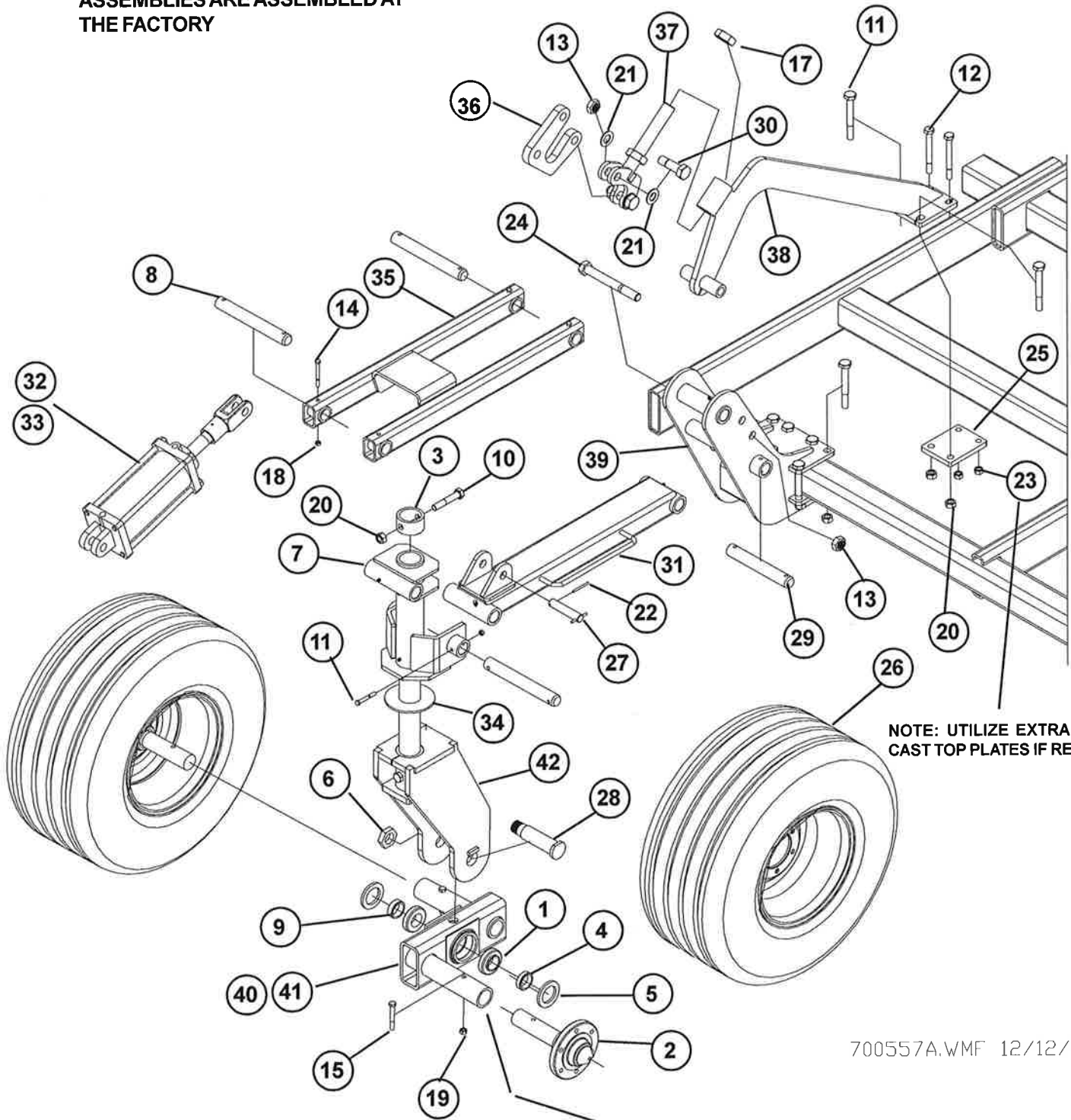

NOTE: UTILIZE EXTRA SHANK  
CAST TOP PLATES IF REQUIRED

700557A.WMF 12/12/11

NOTE: PRE-ASSEMBLED WING  
FRONT CASTER WHEELS ARE  
LEFT AND RIGHT, REFER TO  
UNIT OVERVIEW ON PAGE 16  
FOR CORRECT ORIENTATION.

# WING LIFT WHEEL ASSEMBLY

ITEM	PART NO.	DESCRIPTION	QTY
1	12103	BEARING CONE 1-3/4ID (25580)	2
2	14131	2IN HUB & SPINDLE (LG7830026) BLK	2
3	16009	COLLAR	1
4	16278	BEARING BUSHING	1
5	26120	2.25ID X 3.40 OD TRIPLE LIP SEAL	2
6	42082	NUT 1-1/2NF HYDRA JAM LOCK	1
7	54571	GAUGE WHEEL PIVOT	2
8	54595	HEADLESS PIN(2) 1-1/2 X 9-19/32	3
9	54599	WALKER BEARING BUSHING	1
10	88272	BLT HEX 3/4-10NC X 4 5Z	1
11	88293	BLT HEX 3/4-10NC X 6 5Z	9
12	88295	BLT HEX 5/8-11NC X 6 5Z	2
13	88348	NUT 2POSLK 1-8NC 5Z	3
14	88412	BLT HEX 3/8-16NC X 3-1/2 5Z	4
15	88507	BLT HEX 1/2-13NC X 3-1/2 5Z	2
16	88582	BLT HEX 3/8-16NC X 2-3/4 5Z	4
17	88623	NUT JAM 1-1/2-6NC 5Z	2
18	88659	NUT TOP LK 3/8-16NC 5Z	8
19	88661	NUT TOP LK 1/2-13NC 5Z	2
20	88665	NUT TOP LK 3/4-10NC 5Z	10
21	88738	WSHR FLAT 1SAE(1-1/16 X 2ACT) Z	4
22	88767	PIN ROLL 1/4DIA X 2-1/2 Z	2
23	88845	NUT TOP LK 5/8-11NC 5Z	2
24	89373	BLT HEX 1-8NC X 8-1/2 8YZ	1
25	221196	MOUNT PLATE - PAINTED GRAY	1
26	222087	WHL ASSY 31X13.5 6B 10" 12P GRAY	2
27	222338	HEADLESS PIN(2) 1X4-1/8	1
28	235245	TANDEM PIN	1
29	235801	PIVOT PIN (1-1/2 X 10)	1
30	237506	1NC X 3-1/2 SPECIAL HEX HEAD BOLT	2
31	237798	LOWER OUTER ARM	1
32	241663	HYD CYL 4X8 - Inner Wing	1
33	241664	HYD CYL 3-3/4X8 - Outer Wing	1
34	242933	PIVOT WEAR PLATE	1
35	247798	UPPER LINK ARM	1
36	247808	MAST ANCHOR	1
37	247811	ANCHOR ADJUST	1
38	247814	FRONT MAST SUPPORT	1
39	350923	FRONT ATD MAST - 2012	1
40	237714D1	LEFT OUTER WALKER - ATD	1
41	237714L1	RIGHT OUTER WALKER - ATD	1
42	237722D2	WING FRONT AXLE PIVOT - ATD	1

# MAIN FRAME PACKER/LIFT ASSEMBLY

700750A.WMF 10/12

CYLINDER PINS ARE PROVIDED  
IN ALL LIFT CYLINDER BOXES

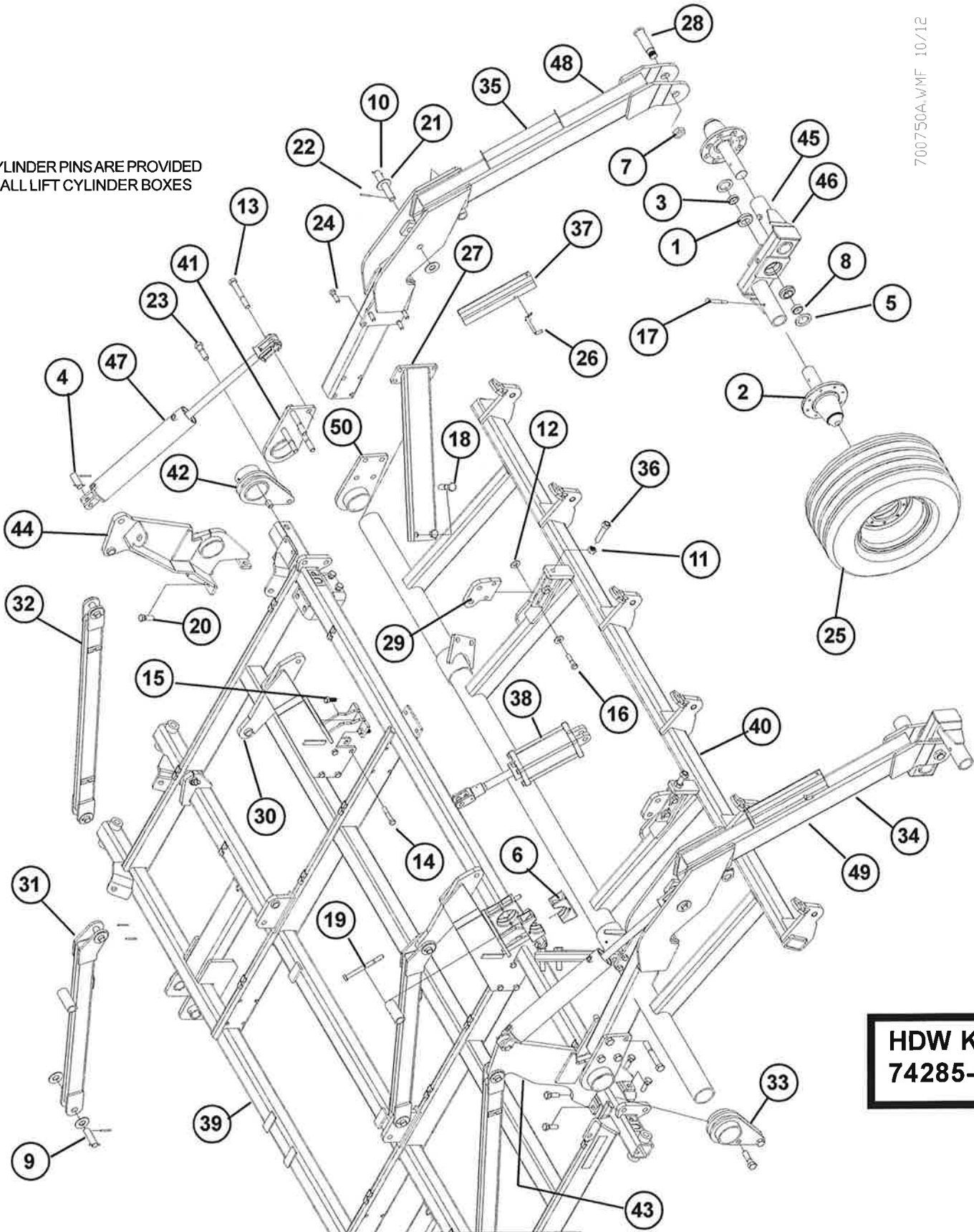

**HDW KIT  
74285-9**



# MAIN FRAME PACKER/LIFT ASSEMBLY

ITEM	PART NO	DESCRIPTION	QTY
1	12103	BEARING CONE 1-3/4ID (25580)	4
2	16154	2-1/2" HUB & SPINDLE ASSY	4
3	16278	BEARING BUSHING	2
4	22022	HEADLESS PIN(2) 1-1/4X2-7/16	2
5	26120	2.25ID X 3.40 OD TRIPLE LIP SEAL	4
6	34132	AXLE CLAMP ASSEMBLY (RED)	8
7	42082	NUT 1-1/2NF HYDRA JAM LOCK	2
8	54599	WALKER BEARING BUSHING	2
9	67854	HEADLESS PIN(2) 1-1/4X4-1/2	8
10	68399	HEADLESS PIN(2) 1-1/4X7-1/8	2
11	88125	NUT HEX 1-8NC 5Z	2
12	88131	WSHR FLAT 3/4(13/16 X 2ACT) Z	8
13	88181	BLT HEX 1-8NC X 7 5Z	8
14	88272	BLT HEX 3/4-10NC X 4 5Z	8
15	88290	BLT HEX 3/4-10NC X 2 8YZ	4
16	88291	BLT HEX 3/4-10NC X 3 5Z	4
17	88381	BLT HEX 5/8-11NC X 4-1/2 5Z	4
18	88398	BLT HEX 1-8NC X 4 5Z	4
19	88487	BLT HEX 3/4-10NC X 8-1/2 5Z	8
20	88495	BLT HEX 7/8-9NC X 2-1/2 5Z	8
21	88602	WSHR FLAT 1-1/4(1-3/8 X 3ACT) Z	20
22	88767	PIN ROLL 1/4DIA X 2-1/2 Z	24
23	89371	BLT HEX 1-8NC X 3-1/2 8YZ	4
24	89389	BLT HEX 3/4-10NC X 2-1/2 8YZ	8
25	222259	WHL ASSY 31X13.5 8B 10" 12P	4
26	234811	1/2 X 4 BENT PIN W/HAIRPIN	2
27	234836	REAR BRACE TUBE	2
28	235245	TANDEM PIN	2
29	350919	PACKER LIFT ANCHOR	2
30	240488	PACKER LIFT BRACKET	2
31	240567	MAIN MAST TUBE	2
32	240572	LIFT MAST TUBE	2
33	241513	CENTER PACKER HANGER	1
34	241550	LEFT REAR LIFT AXLE ASSY /WALKER	1
35	241551	RIGHT REAR LIFT AXLE ASSY /WALKER	1
36	241572	ADJUSTMENT SCREW	2
37	241584	REAR CYLINDER CHANNEL LOCK	2
38	241623	HYD CYL 4-3/4X8 SEQ	2
39	244832	MAIN FRAME - 5015/6015 ATD	1
40	244860	CENTER PACKER MOUNT 6015 ATD	1
41	244862	LIFT AXLE PIVOT - SHORT	1
42	244863	CENTER PACKER HANGER	1
43	245697	REAR LIFT MAST - LEFT	1
44	245698	REAR LIFT MAST - RIGHT	1
45	221347D1R	LEFT 3X11 HD WALKING TANDEM	1
46	221347D1	RIGHT 3X11 HD WALKING TANDEM	1
47	222213F1	HYD CYL 4X16 ILP #A519CY26	2
48	237756D1R	REAR LIFT AXLE - RIGHT	1
49	237756D1	REAR LIFT AXLE - LEFT	1
50	237961D1	LIFT AXLE PIVOT	3

UNLESS SPECIFIED, ALL HARDWARE IS SECURED WITH MATCHING LOCK NUTS.  
 QUANTITIES MAY VARY BY MODEL CONFIGURATION.

# REAR PACKER ASSEMBLY

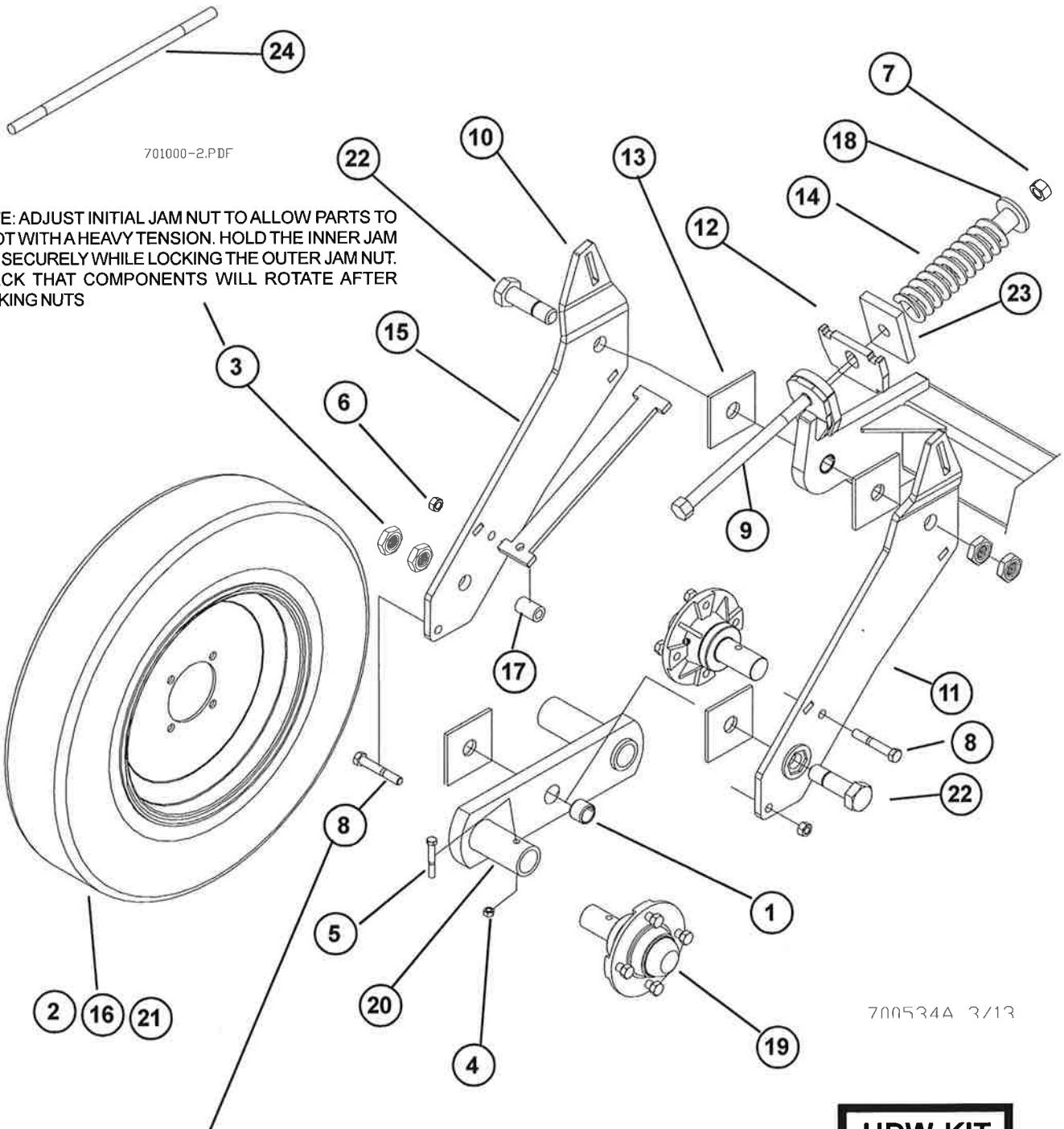

701000-2.PDF

NOTE: ADJUST INITIAL JAM NUT TO ALLOW PARTS TO PIVOT WITH A HEAVY TENSION. HOLD THE INNER JAM NUT SECURELY WHILE LOCKING THE OUTER JAM NUT. CHECK THAT COMPONENTS WILL ROTATE AFTER LOCKING NUTS

700534A 3/13

NOTE THE ORIENTATION OF THESE BOLTS - ITEM 8 QTY 2. IMPROPER ASSEMBLY CAN ALLOW THE BOLTS TO CONTACT THE PACKER TIRE AND CAUSE PROBLEMS

**HDW KIT  
74285-10**

## REAR PACKER ASSEMBLY

ITEM	PART NO.	DESCRIPTION	QTY
1	33515	SPRING TENSION BUSHING (1")	2
2	57908	VALVE ASSEMBLY (STEEL)	1
3	88141	NUT JAM 1-8NC 5Z	4
4	88162	NUT 2POSLK 3/8-16NC 5P	2
5	88489	BLT HEX 3/8-16NCX2-1/2 8YZ	2
6	88661	NUT TOP LK 1/2-13NC 5Z	2
7	88665	NUT TOP LK 3/4-10NC 5Z	1
8	88680	BLT HEX 1/2-13NCX3-1/4 5Z	1
9	89462	BLT-HEX 3/4X10NCX10-1/2 8Z	1
10	233508	LEFT PACKER ARM	1
11	233509	RIGHT PACKER ARM	1
12	237986	SPRING PLATE—PAINTED BLACK	1
13	237996	WALKER PIVOT WASHER	4
14	239169	SPRING - PAINTED BLACK	1
15	241541	INNER PACKER PLATE (BLACK)	1
16	241616	PACKER RIM 4.5X15 4 BOLT	1
17	241653	PACKER SPACER (ZINC)	1
18	243953	SPRING CENTERING WASHER/TUBE	2
19	243985	2009 PACKER HUB & SPINDLE ASSY	2
20	244889	PACKER WALKER - 15 IN	1
21	241617	PACKER TIRE 26/6.50X15	1
22	350999	1NCX3-3/4 HEXHEAD - WALKER PIVOT BOLT	2
23	A34852	PLATE-TDD SPRING RETAINER	1
24	351575	DOUBLE SPRING ROD - MAIN FRAME ONLY	1

**NOTE: DO NOT FOLD OR UNFOLD THE OUTER WINGS WITHOUT MOVING THE UNIT FORWARD. IT IS RECOMMENDED THAT THE TWO PACKER WHEELS NEAREST THE OUTER WING HINGE ON EACH OUTER WING BE REMOVED IF THE UNIT IS BEING FOLDED WHILE SETTING STILL DURING ASSEMBLY. THE FOLDING PROCEDURE CAN PLACE EXCESSIVE SIDE LOADING ON THESE COMPONENTS AND CAUSE FAILURES. WHEN FOLDING AND UNFOLDING THE WINGS THE UNIT MUST ALWAYS BE MOVING TO ALLOW THE TIRES TO SLIDE INTO POSITION. ONCE UNIT IS COMPLETED, ATTACH THE PACKER WHEELS IN THESE LOCATIONS.**

## PACKER ASSEMBLY/SETTING INFORMATION

ONCE EACH PACKER ASSEMBLY HAS BEEN COMPLETED WITHOUT MOUNTING THE SPRING, IT IS CRITICAL TO PROPERLY SET THE TIGHTNESS OF THE PACKER ADJUST POINTS INDICATED. **THE SPRING LOADED PACKER ASSEMBLIES WILL NOT FUNCTION PROPERLY IF THE NOTED POINTS ARE OVER TIGHTENED. BOTH THE SPRING PIVOT ARMS AND PACKER WALKERS MUST ROTATE FREELY.**

TIGHTEN THE UPPER AND LOWER MAIN PIVOT BOLTS BY ADJUSTING THE INNER JAM NUT. CHECK TO ENSURE THE ARMS AND WALKER ARE FREE TO PIVOT. HOLD THE INNER JAM NUT WITH A WRENCH AND LOCK WITH THE OUTER JAM NUT. **DO NOT USE AN AIR WRENCH TO TIGHTEN ANY OF THE PACKER ADJUST POINTS.** ADJUST THE TWO (2) CLAMP BOLTS, CHECKING TO ENSURE THAT THE WALKER IS FREE TO PIVOT.

IF THE PACKER ADJUST POINTS ARE TIGHT THE SPRING WILL NOT RETURN THE SPRING ARMS TO THE CORRECT POINT AND THE DEPTH CONTROL AND PACKING OF THE REAR OF THE UNIT WILL BE INCONSISTENT. WITH THE PACKER ARMS AND WALKERS ABLE TO ROTATE AND THE SPRINGS SET AS NOTED BELOW THE PACKERS SHOULD CARRY THE REAR OF THE UNIT AT A CONSISTENT DEPTH AND ALLOW THE SPRING LOADED ARMS TO PIVOT WHEN OBSTACLES ARE ENCOUNTERED.

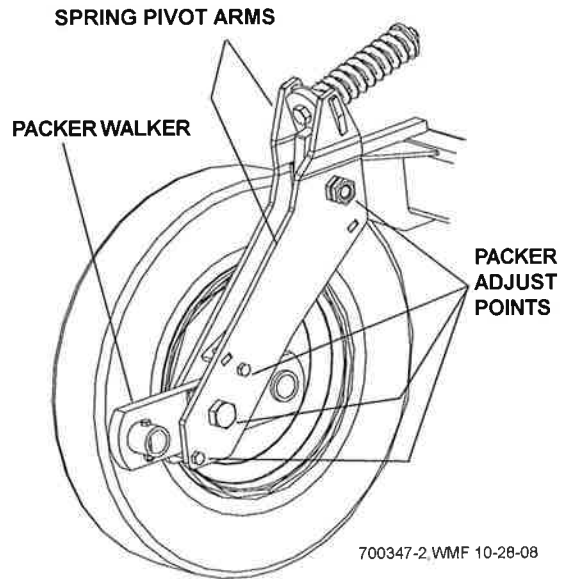

### PACKER SPRING SETTINGS

TO MAINTAIN PROPER REAR MACHINE DEPTH THE SPRING ON EACH PACKER ASSEMBLY MUST BE ADJUSTED TO BALANCE THE WEIGHT OF THE MACHINE AND ALLOW PROPER RELIEF OF THE PACKER WHEELS WHEN ENCOUNTERING UNEVEN TERRAIN. ONCE THE PACKER PIVOTS HAVE BEEN PROPERLY ADJUSTED AS NOTED ABOVE THE SPRING CAN BE ADDED AND THE SPRING NUTS ADJUSTED. THIS SHOULD BE DONE WHEN THE UNIT IS COMPLETELY ASSEMBLED AND LEVELLED ON A FLAT SURFACE PRIOR TO GOING TO THE FIELD. LOWER THE UNIT SO THE SHANKS OR INJECTORS JUST CLEAR THE GROUND.

ALL SPRINGS SHOULD BE SET TO MAINTAIN CONTACT BETWEEN THE SPRING PLATE AND THE FRAME STOP ON EACH PACKER PIVOT. THIS SETTING IS DEPENDENT ON THE LOAD THAT IS SEEN BY EACH PACKER. SINCE THERE IS MORE WEIGHT ON MOST OF THE MAIN FRAME PACKERS THE SPRING SETTING (SS) WILL BE GREATER THAN REQUIRED ON THE OUTER WINGS. SET THE SPRING DISTANCE (SS) ON ALL SPRINGS TO MAINTAIN THE SPRING PLATE TO FRAME STOP CONTACT WITH THE WEIGHT OF THE UNIT. WHEN PROPERLY SET THE PACKERS SHOULD NOT MOVE EXCESSIVELY UNLESS THE PACKER WHEELS ENCOUNTER UNEVEN GROUND OR AN OBSTRUCTION.

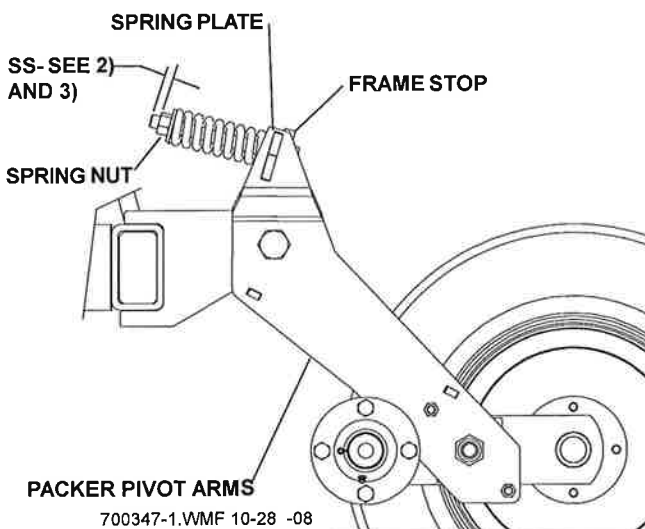

1) WITH THE MAIN FRAME LEVEL TIGHTEN THE SPRING BOLT TO A (SS) DISTANCE OF APPROXIMATELY 3/8"-1/2" ON ALL THE MAIN FRAME PACKERS.

2) TIGHTEN THE PACKER SPRINGS ON THE INNER PORTION OF THE INNER WINGS TO A (SS) DISTANCE OF 3/8"-1/2" WITH THE REMAINING WING PACKER SPRINGS TO A LESSER DISTANCE.

3) DEPENDING ON THE WEIGHT AND SIZE OF THE UNIT TIGHTEN THE REMAINING PACKER SPRINGS ON THE OUTER WINGS TO A 1/4" TO 3/8" DIMENSION.

4) CHECK TO ENSURE THAT THE SPRING PLATE TO FRAME STOP CONTACT IS MAINTAINED TO ENSURE THAT ALL PACKERS ARE SET TO THE SAME DEPTH.

5) PROCEED TO COMPLETING THE FIELD SETTINGS AND CHECK TO SEE THAT THE STOP CONTACT IS MAINTAINED AS THE UNIT MOVES THROUGH THE FIELD. IF THE PACKER PIVOT ARMS ARE MOVING EXCESSIVELY DUE TO NORMAL LOADING, NOT OBSTRUCTIONS, TIGHTEN THE SPRING NUTS. TIGHTEN SPRINGS ONLY TO THE POINT OF MAINTAINING SPRING PLATE TO FRAME STOP CONTACT WHILE OPERATING EXCESS SPRING PRESSURE WILL RESTRICT RELIEF WHEN ENCOUNTERING OBSTRUCTIONS.

## REAR PACKER ASSEMBLY

WHEN MOUNTING PACKER ARMS IN CERTAIN LOCATIONS WHERE THERE IS POTENTIAL INTERFERENCE WITH MACHINE PARTS THE SPRING CAN BE MOUNT TO THE REAR AS SHOWN BELOW. FOLLOW THE ASSEMBLY AND ADJUSTMENT INSTRUCTIONS AS NOTED FOR SPRING SETTINGS.

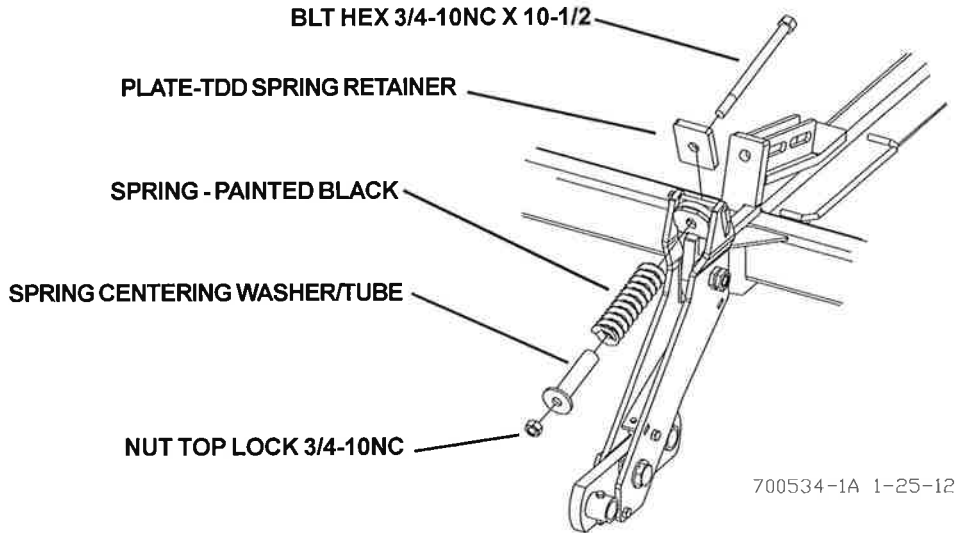

## MAIN FRAME REAR PACKER ASSEMBLY

TO COMPENSATE FOR THE ADDED WEIGHT OF THE MAIN FRAME AND ASSOCIATED COMPONENTS THE REAR PACKERS ON THE MAIN FRAME WILL REQUIRE A DOUBLE SPRING MOUNTING. USE OF THE DOUBLE SPRINGS ON THE MAIN FRAME GIVES ADDED SUPPORT TO MAINTAIN THE PROPER SPRING PLATE AND FRAME STOP CONTACT AS NOTED IN THE "PACKER SPRING SETTINGS" INSTRUCTIONS. TIGHTEN BOTH NUTS TO INCREASE THE PACKING FORCE TO MAINTAIN THE SPRING PLATE TO FRAME STOP CONTACT.

NOTE: AT SOME LOCATIONS, AS NOTED ABOVE, IT MAY NOT BE POSSIBLE TO MOUNT BOTH SPRINGS, USE THE SINGLE SPRING MOUNTING AS NOTED ABOVE. USE OF THE DOUBLE SPRING IS ONLY REQUIRED ON THE MAIN FRAME PACKERS

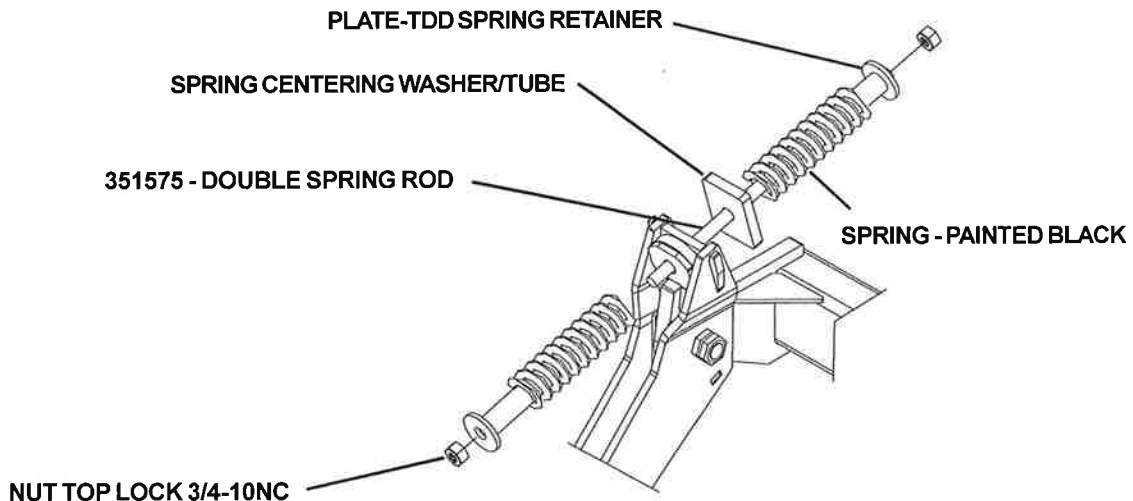

# REAR HITCH ASSEMBLY

Position Hose Brackets (241625) along length of rear hitch to attach hydraulic hoses.

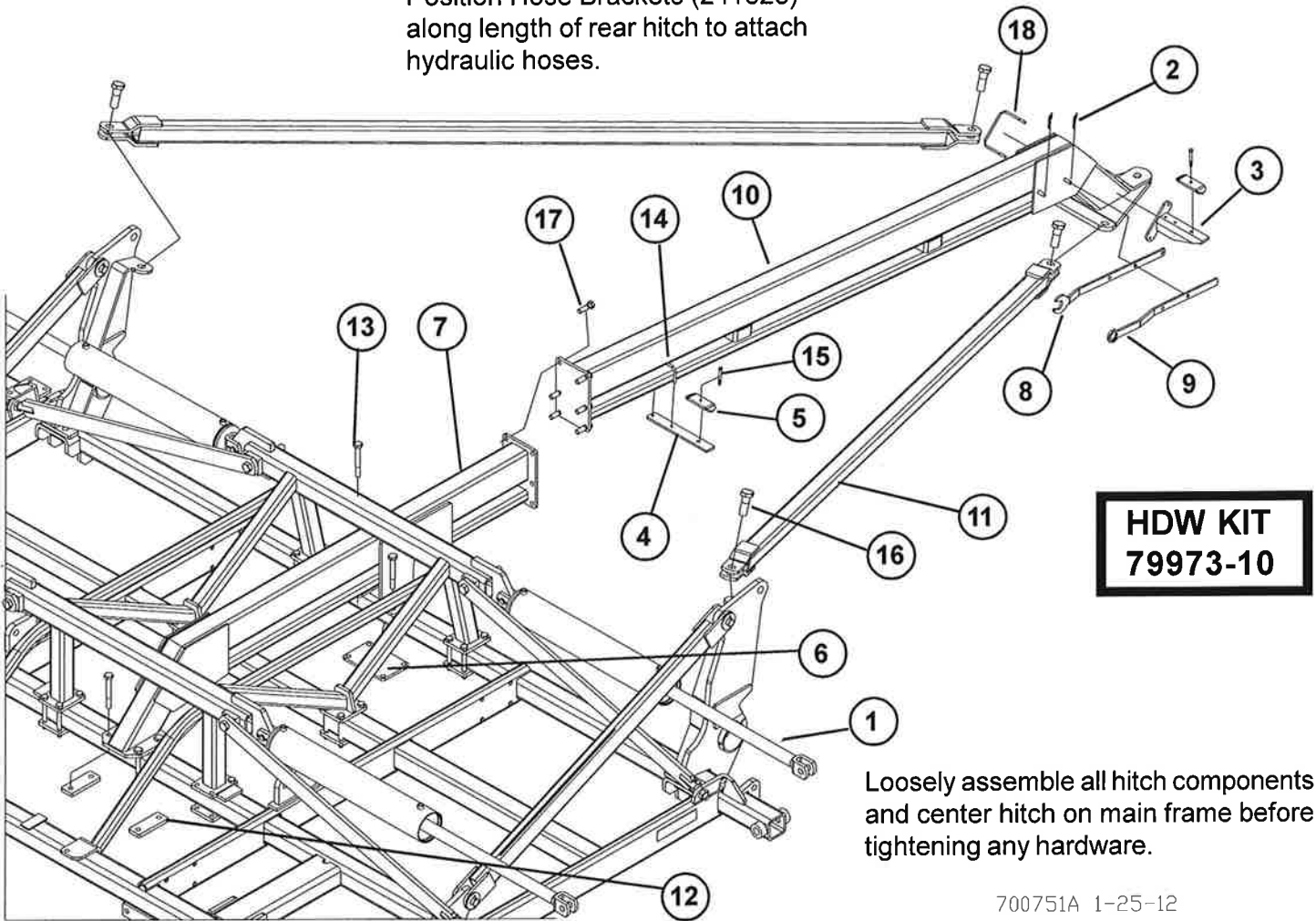

Loosely assemble all hitch components and center hitch on main frame before tightening any hardware.

700751A 1-25-12

ITEM	PART NO.	DESCRIPTION	QTY
1	20966F	HYD CYL 5X30 FGS #A519CY07	4
2	23039	PIN-HAIR .14 X 2.69 ZP	2
3	235262	HOSE BRACKET - PRE 2013 ONLY	1
4	241625	HOSE BRACKET	6
5	241626	HOSE CLAMP	7
6	241639	REAR HITCH PLATE (RED)	1
7	243908	ATD HITCH - SHORT FRONT	1
8	243987	PACKER OPEN END WRENCH	1
9	243988	PACKER BOX END WRENCH	1
10	245695	REAR PULL HITCH - 2010	1
11	245696	REAR HITCH BRACE TUBE	2
12	53419	STRAP (RED)	2
13	88293	BLT HEX 3/4-10NCX6 5Z	8
14	88515	BLT-U 3/8-16NCX4X2-3/4 Z	6
15	88531	BLT HEX 3/8-16NCX3 5Z	7
16	89029	BLT HEX 1-1/4-7NC X 4 5Z	4
17	89389	BLT HEX 3/4-10NCX2-1/2 8YZ	6
18	89406	BLT-U 3/8-NCX6 X 5 - PRE 2013 ONLY	1

# LIFT SENSOR MOUNT ASSEMBLY

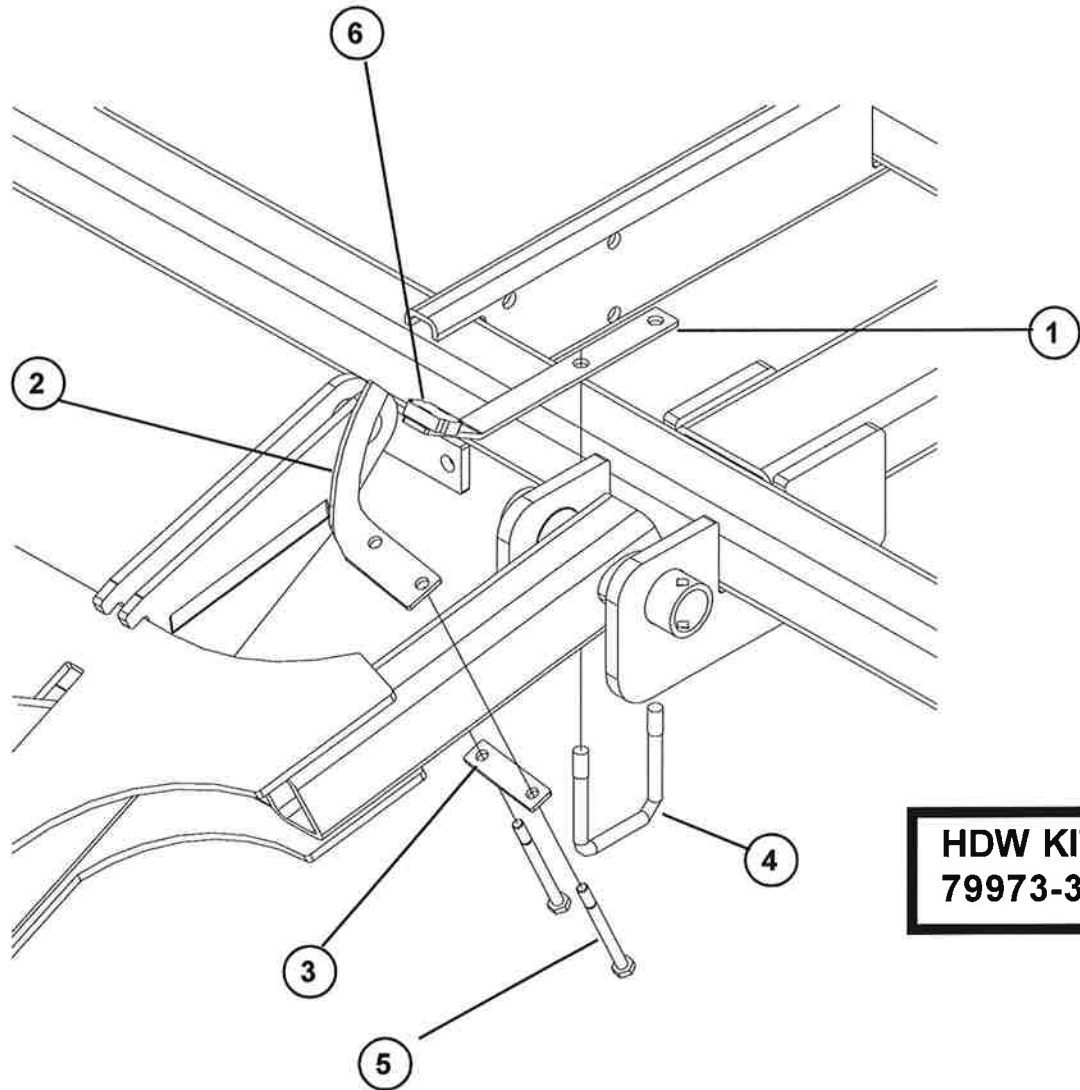

700350MODA 1-25-12

ITEM	PART NO	DESCRIPTION	QTY
1	241677	SENSOR MOUNT	1
2	241678	SENSOR PLATE	1
3	241679	TIE STRAP	1
4	88145	BLT-U 5/8-11NCX4X5-1/4 Z	1
5	88676	BLT HEX 1/2-13NC X 6-1/2 5Z	2
6	SENSOR	SENSOR	1

**UNLESS SPECIFIED, ALL HARDWARE IS SECURED WITH MATCHING LOCK NUTS.  
QUANTITIES MAY VARY BY MODEL CONFIGURATION.**

# SHANK ASSEMBLY

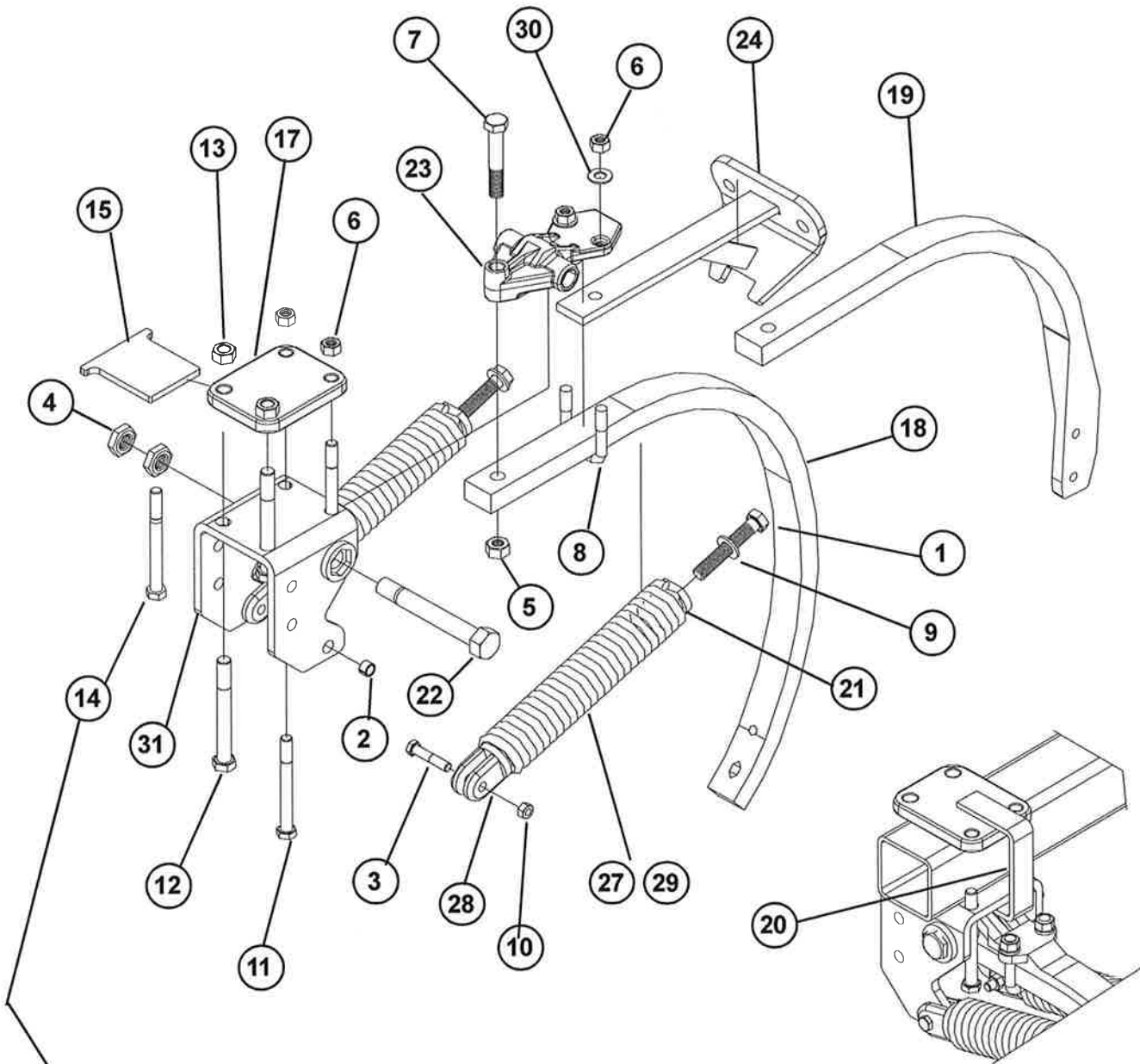

89398 BOLT USED WITH 241764 SHIM  
AND 241675 SHIM KIT

700383-B.WMF 10/12

**USE BRACKET (244576) TO HOLD  
SHANK FOR ASSEMBLY**



# SHANK ASSEMBLY

ITEM	PART NO.	DESCRIPTION	QTY
	351663	EDGE-ON CHISEL SHANK ASSY. 650LB (BLACK) (2013 AND NEWER)	
1	10210	ADJUSTMENT BOLT	2
2	56908	1/2" SPRING TENSION BUSHING	2
3	58032	HDN 1/2 X 2-1/2 BOLT	2
4	88141	NUT JAM 1-8NC 5Z	2
5	88356	NUT 2POSLK 3/4-10NC 5Z	1
6	88369	NUT 2POSLK 5/8-11NC 5Z	2
7	88421	BLT HEX 3/4-10NC X 4-1/2 5Z	1
8	88441	BLT-U 5/8-11NCX2X3-1/4 Z	1
9	88548	WSHR FLAT 3/4SAE(13/16 X 1-1/2) Z	2
10	88621	NUT NLK 1/2-13NC 5Z	2
11	88933	BLT HEX 5/8-11NC X 6 8YZ	2
12	89385	BLT HEX 3/4-16NF X 6-1/2 8YZ	2
13	89386	NUT NYL 3/4-16NF 8YZ	2
14	89398	BLT HEX 5/8-11NC X 6-1/2 8YZ	2
15	241674	3/8 IN SHANK SHIM (ZINC)	12
16	241675	SHANK SHIM KIT - 12 EA	1
17	243956	CAST TOP PLATE (BLACK)	1
18	243959	54 DEG 32IN CP SHK (BLACK)	1
19	243961	SHANK EDGE ON (BLACK)	1
20	244576	SHANK MOUNT TOOL	1
21	251696	CAST SPRING PLUG (BLACK)	1
22	350988	SHANK PIVOT BOLT	1
23	351550	DUCTILE PIVOT (BLACK)	1
24	351551	SHANK SPRING BRACKET (BLACK)	1
25	351662	CHISEL PLOW SHANK 650LB (BLACK) (PRE 2012)	1
26	351697	SPRING ASSY W/PLUGS (BLACK)	1
27	351698	CAST SPRING YOKE (BLACK)	1
28	351699	EXTENSION SPRING (BLACK)	1
29	88630	WSHR FLT 5/8SAE(21/32 X 1-5/16) Z	2
31	243957	SHANK HOLDER FRAME BRKT (BLACK)	1

# SHANK COULTER MOUNT ASSEMBLY

LOCATE SHORT MOUNTS ON SHANKS THAT INTERFERE WITH FRONT LIFT TIRES.

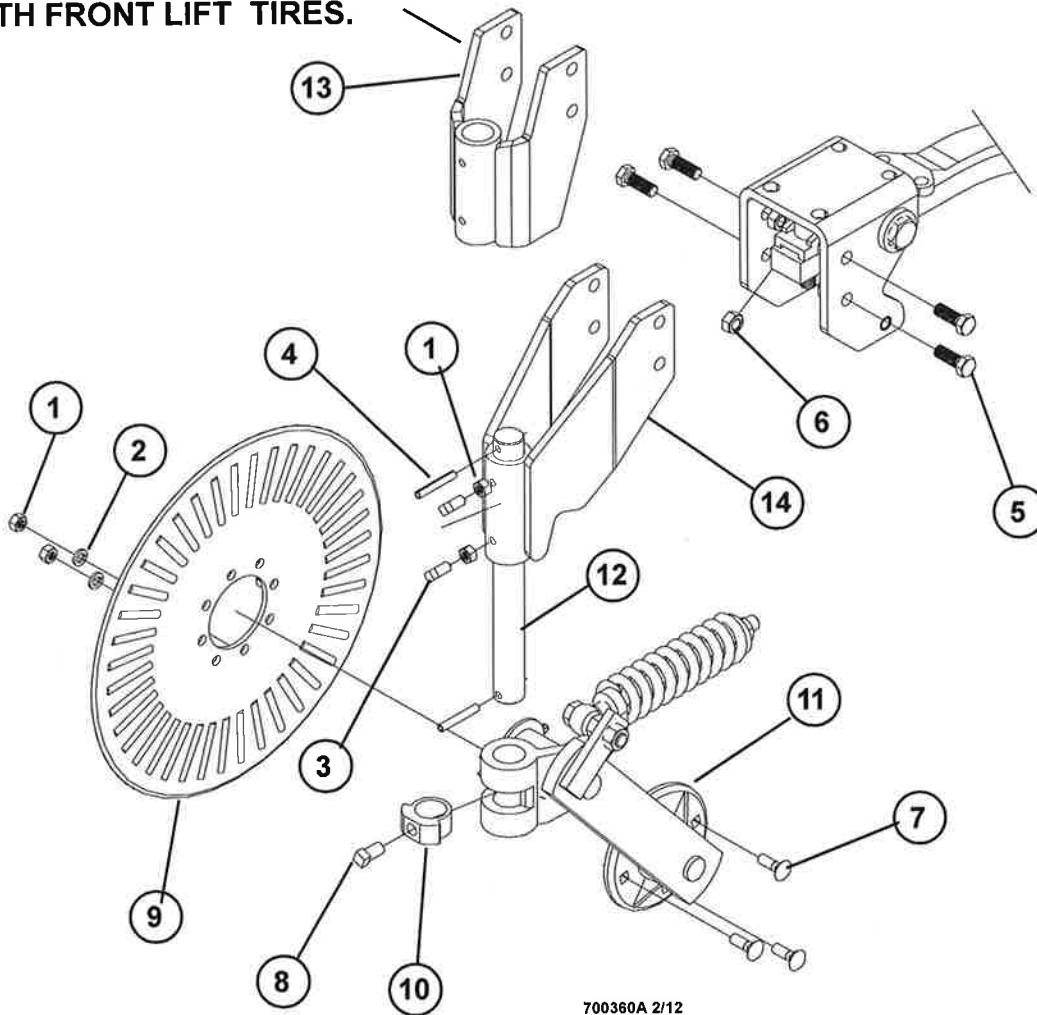

700360A 2/12

ITEM	PART NO	DESCRIPTION	QTY
1	88104	NUT HEX 1/2-13NC 5Z	6
2	88303	WSHR HLK 1/2ID(9/16ACT) Z	4
3	88446	SCR SET 1/2-13NC X 1SQHD Z	2
4	88770	PIN ROLL 3/8DIA X 2-1/2 Z	1
5	88838	BLT HEX 5/8-11NC X 1-3/4 5Z	4
6	88845	NUT TOP LK 5/8-11NC 5Z	4
7	88873	BLT CRG 1/2-13NC X 1-1/2 5Z	4
8	89382	SCR SET 5/8-11NC X 1 SQ HD P	1
9	234261	20" RIPPLE BLADE	1
10	234262	LOCKING COLLAR CLYMER COULTER	1
11	234264	CLYMER COULTER ASSY W/HARDWARE	1
12	235806	SHORT SHAFT - 1-1/2 IN DIA COULTER	1
13	350915	CP SHANK COULTER MOUNT - SHORT	1
14	351508	COULTER MOUNT 2012	1

# CLYMER SHANK COULTER ASSEMBLY

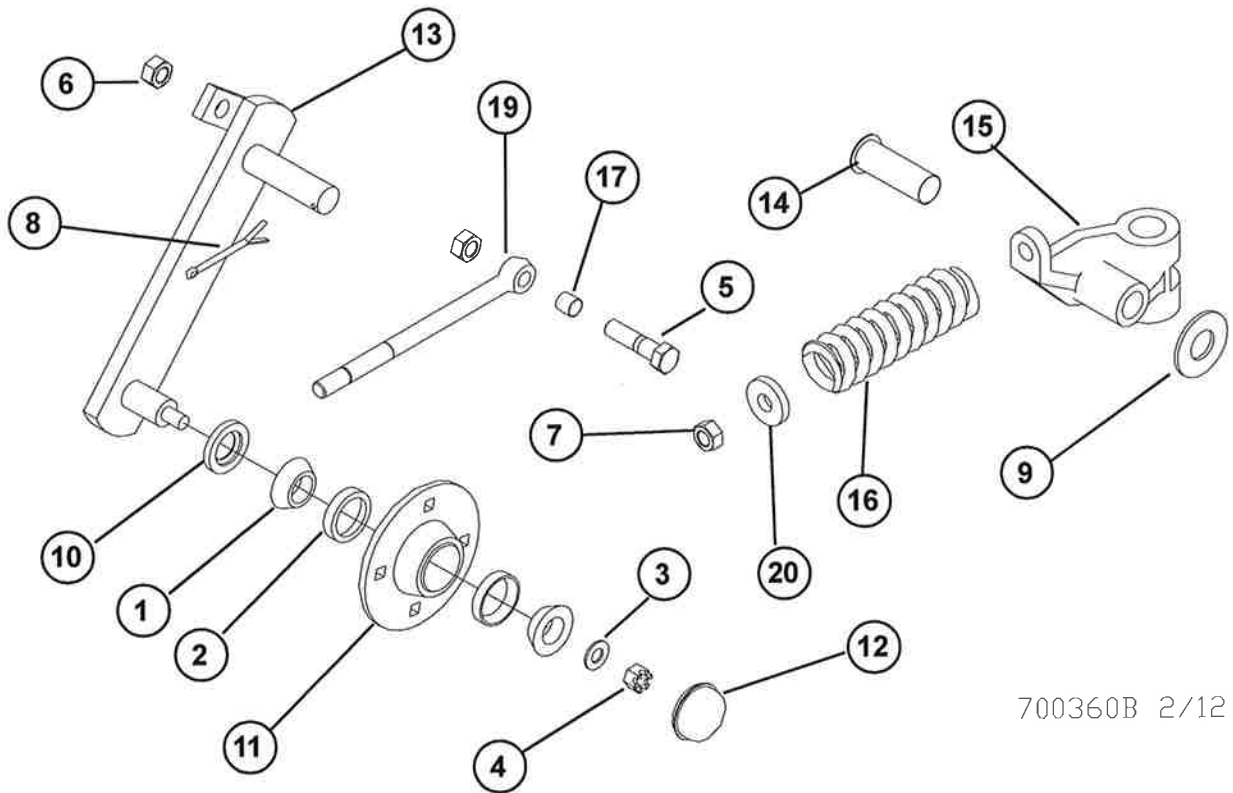

700360B 2/12

ITEM	PART NO	DESCRIPTION	QTY
1	10344	BEARING CUP 2.328 OD (LM67010)	2
2	10345	BEARING CONE 1-1/4ID (LM67048)	2
3	19949	3/4ID SPINDLE WASHER	1
4	86558	NUT SLTD 5/8-18NF 5	1
5	88119	BLT HEX 3/4-16NF X 3 5Z	1
6	88306	NUT 2POSLK 3/4-16NF 5Z	2
7	88356	NUT 2POSLK 3/4-10NC 5Z	1
8	88559	PIN COT 5/32DIA X 1 Z	1
9	88602	WSHR FLAT 1-1/4(1-3/8 X 3ACT) Z	1
10	234252	2 PIECE GREASE SEAL CLYMER W40-2	1
11	234255	4-BOLT HUB CLYMER W23	1
12	234256	DUST CAP CLYMER W50	1
13	234257	SWING ARM CLYMER N347-4	1
14	234258	FLANGED BUSHING CLYMER N347-6	1
15	234259	HINGE CASTING CLYMER N347-1	1
16	234260	COULTER SPRING CLYMER S233	1
17	234263	NYLON BUSHING CLYMER N347-7	1
18	234264	CLYMER COULTER ASSY W/HARDWARE	1
19	234265	SPRING ROD CLYMER N347-5	1
20	236553	SPRING BUSHING CASTING	1

# UNIVERSAL DISC LEVELER - VERSION A

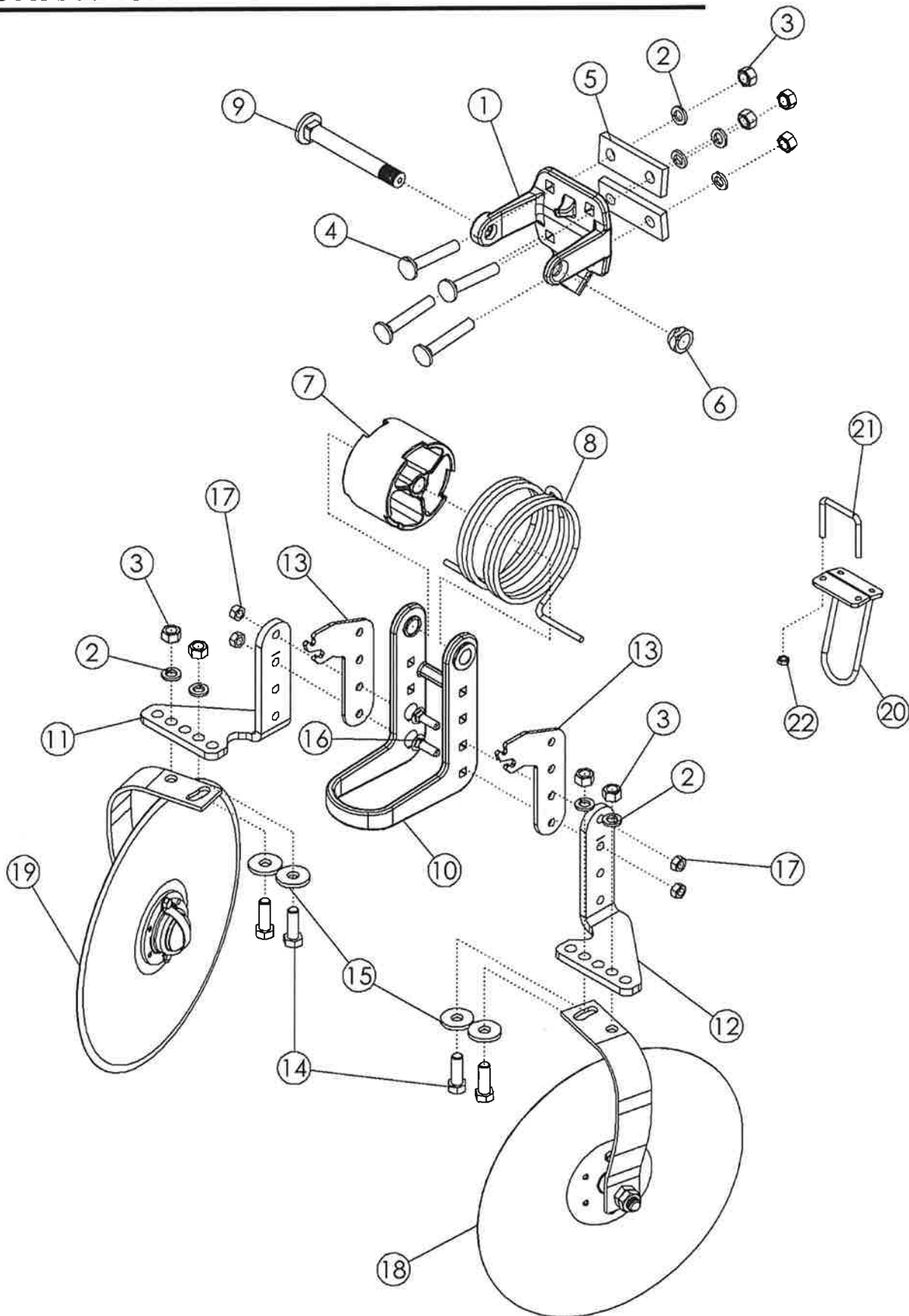

# UNIVERSAL DISC LEVELER - VERSION A

ITEM	PART NO.	DESCRIPTION	QTY
1	67415	CARRIER-CENTER PC	1
2	88303	WSHR HLK 1/2ID(9/16ACT) Z	8
3	88104	NUT-HEX: .50 NC ZP	8
4	67402	BOLT-CARR 1/2-13X3 1-1/2 THRD ZP	4
5	67133	PLATE-BACKING ZP	2
6	344003	NUT-CENTERLOCK LUG .75 NC ZP	1
7	67409	SPACER-CENTER CARRIER	1
8	67207	SPRING-TORSION UNIVERSAL	1
9	34820	BOLT-CRG .75 X 5.75	1
10	67482	ASSY-DISC LEVELER ARM	1
11	344042	PLATE-WING A UNIVERSAL LONG	1
12	344043	PLATE-WING B UNIVERSAL LONG	1
13	67934	ARM-SHIFTER ZP	2
14	88475	BLT HEX 1/2-13NC X 1-1/2 5Z	4
15	33036	WASHER-FLAT: .50 ZP HD	4
16	89010	BLT CRG 3/8-16NC X 1-1/4 5Z	4
17	88103	NUT HEX 3/8-16NC 5Z	4
18	66479	ASSY-RIGHT DISC ARM	1
19	66478	ASSY-LEFT DISC ARM	1
20	344105	WLDMT-HOSE HOLDER	1
21	344044	U-BOLT: .250 X 2.00 X 2 X 2.00	1
22	89501	NUT TOP LK 1/4-20NC 5Z	2

# UNIVERSAL DISC LEVELER - VERSION B

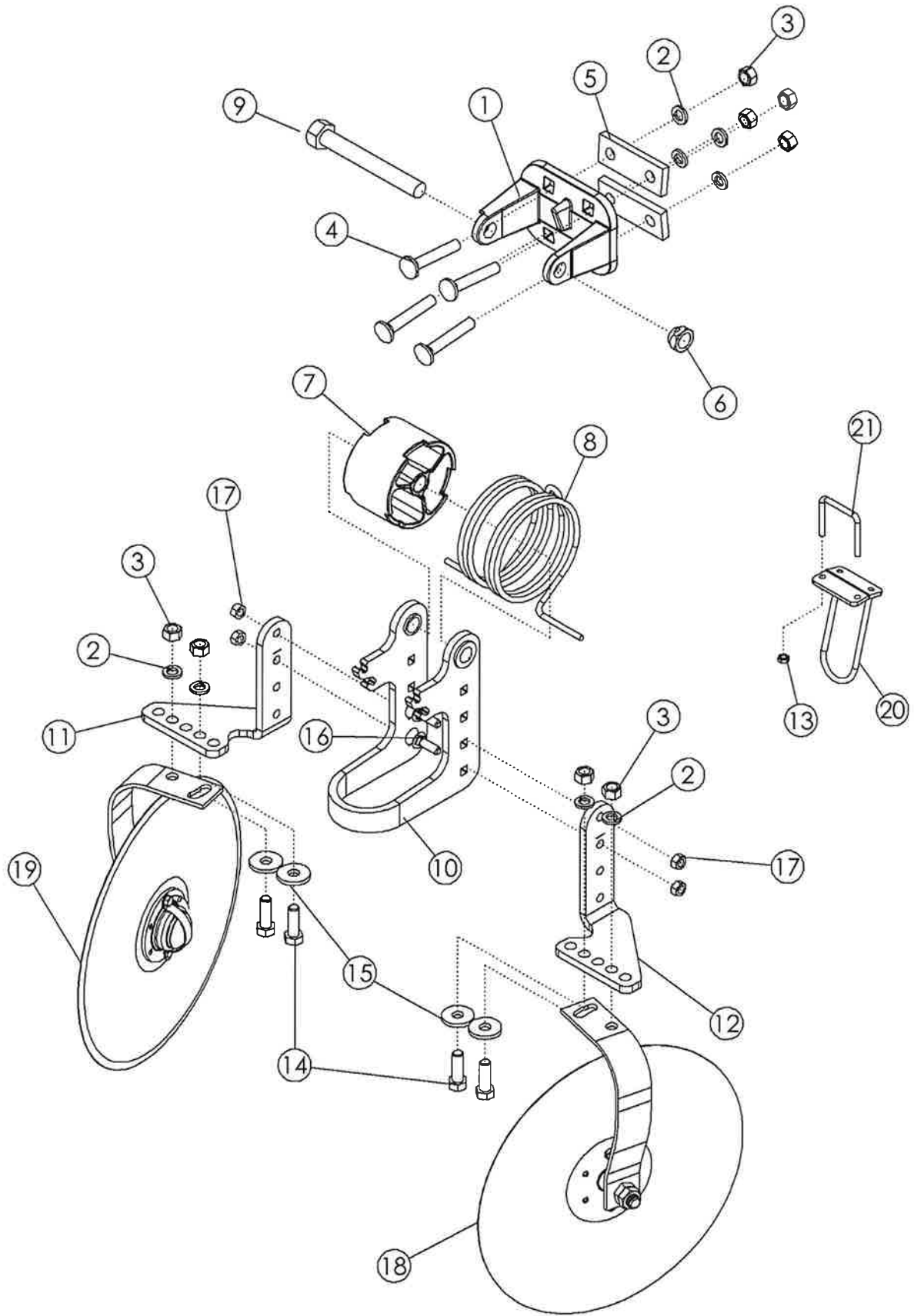

# **UNIVERSAL DISC LEVELER - VERSION B**

<b>ITEM</b>	<b>PART NO.</b>	<b>DESCRIPTION</b>	<b>QTY</b>
1	344094	CARRIER-CENTER PC	1
2	88303	WSHR HLK 1/2ID(9/16ACT) Z	8
3	88104	NUT-HEX: .50 NC ZP	8
4	67402	BOLT-CARR 1/2-13X3 1-1/2 THRD ZP	4
5	67133	PLATE-BACKING ZP	2
6	88356	NUT 2POSLK 3/4-10NC 5Z	1
7	67409	SPACER-CENTER CARRIER	1
8	67207	SPRING-TORSION UNIVERSAL	1
9	344109	BOLT-HEX: .75 X 6 X 1.00 THD NC GR5 ZP	1
10	344097	ASSY-DISC LEVELER ARM	1
11	344042	PLATE-WING A UNIVERSAL LONG	1
12	344043	PLATE-WING B UNIVERSAL LONG	1
13	89501	NUT TOP LK 1/4-20NC 5Z	2
14	88475	BLT HEX 1/2-13NC X 1-1/2 5Z	4
15	33036	WASHER-FLAT: .50 ZP HD	4
16	89010	BLT CRG 3/8-16NC X 1-1/4 5Z	4
17	88103	NUT HEX 3/8-16NC 5Z	4
18	66479	ASSY-RIGHT DISC ARM	1
19	66478	ASSY-LEFT DISC ARM	1
20	344105	WLDMT-HOSE HOLDER	1
21	344044	U-BOLT: .250 X 2.00 X 2 X 2.00	1

# 4 BOLT PACKER HUB & SPINDLE

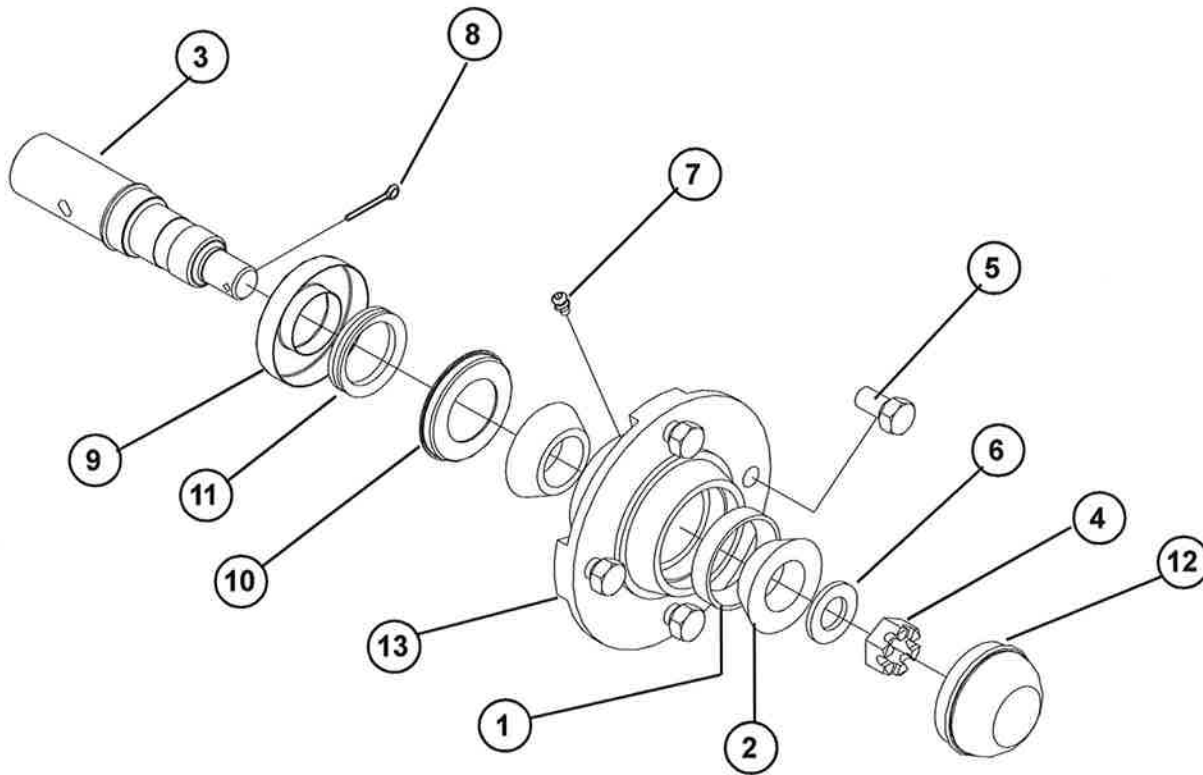

700541 1-24-12

## 243985 - COMPLETE HUB & SPINDLE ASSY PAINTED BLACK

ITEM	PART NO.	DESCRIPTION	QTY
1	10344	BEARING CUP 2.328 OD (LM67010)	2
2	10345	BEARING CONE 1-1/4ID (LM67048)	2
3	244585	PACKER SPINDLE	1
4	88340	NUT SLTD 7/8-14NF 5Z	1
5	89461	BLT-WHL 1/2-20 UNF X .75	4
6	88354	WSHR FLT 7/8SAE(15/16 X 1-3/4) Z	1
7	88550	FTG GRS 1/4-28 3038-B	1
8	88560	PIN COT 1/8DIA X 1-1/4 Z	1
9	A33555	SEAL RETAINER	1
10	A33556	SEAL COUNTERFACE	1
11	A33557	V-SEAL	1
12	A33879	HUB CAP	1
13	A34545	PACKER HUB	1



# 6-BOLT HUB & 2" SPINDLE

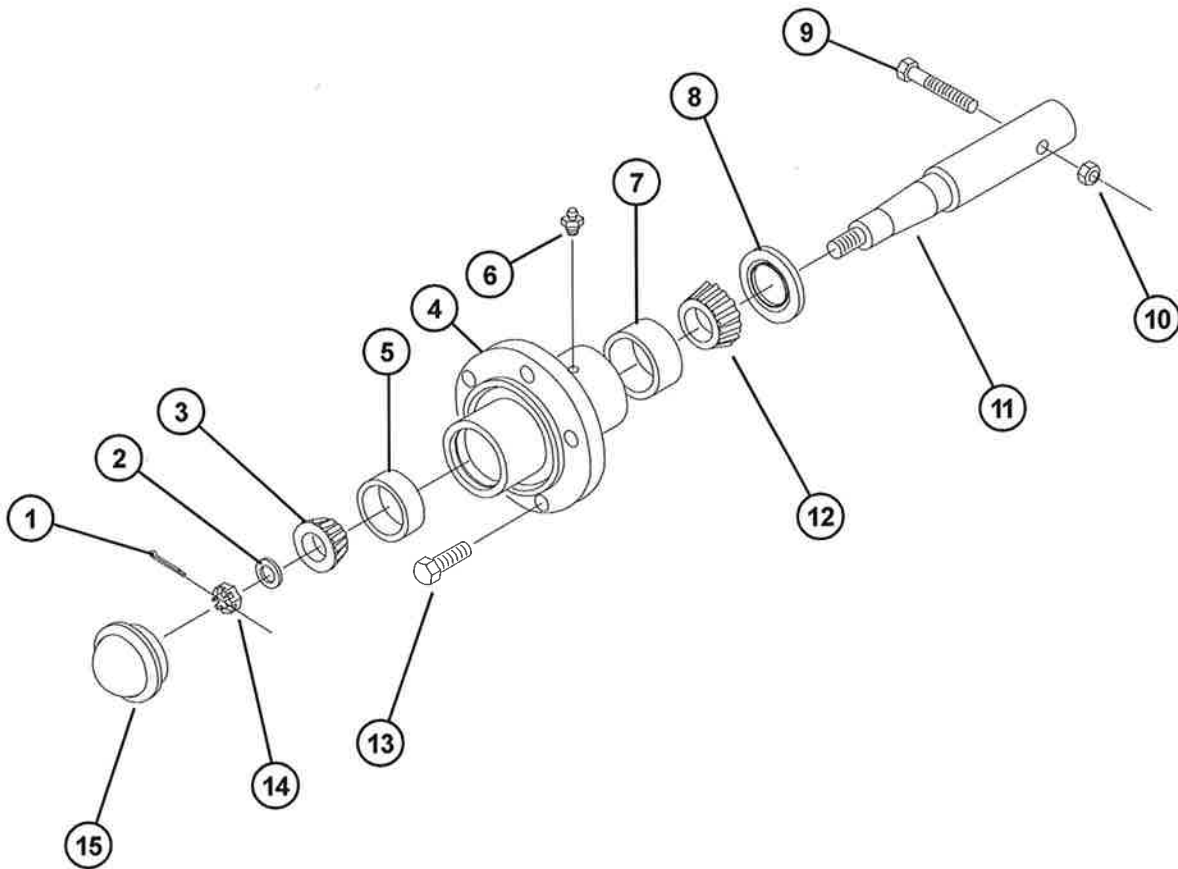

77836.PLT

ITEM	PART NO.	DESCRIPTION
	14131	2" HUB & SPINDLE ASSY (INCLUDES 1-8 & 11-15)
1	88301	PIN COT 3/16 DIA x 1-1/2
2	16094	SPINDLE WASHER 7/8 ID
3	10345	BEARING CONE 1-1/4 ID (LM67048)
4	24097	6-BOLT HUB W/CUPS
5	10344	BEARING CUP 2.328 OD (LM67010)
6	88263	FTG GRS 1/8 NPT 1610-BL (11/16")
7	14249	BEARING CUP 2.891 OD (LM501310)
8	58546	2" TRIPLE LIP SEAL
9	88429	1/2 NF x 3/4 GR5 BOLT
10	88304	NUT 2 POS LK 1/2 NF
11	14251	2" AXLE SPINDLE
12	14248	BEARING CONE 1-5/8 ID (LM501349)
13	88142	WHEEL BOLT 1/2 NF x 1 (13/16 HEAD)
14	88340	NUT SLTD 7/8 NF
15	11381	DUST CAP

# 8-BOLT HUB & 2-1/2" SPINDLE

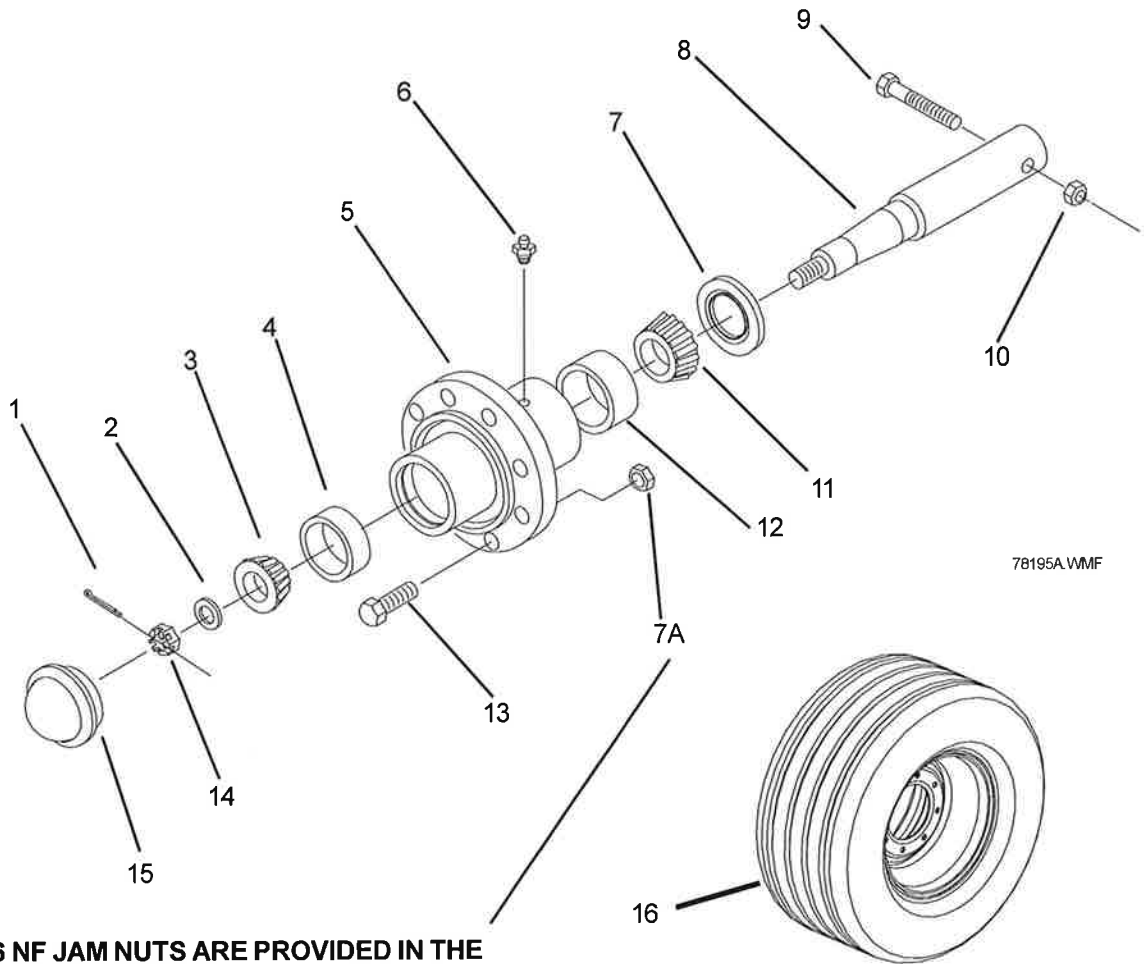

**NOTE: 9/16 NF JAM NUTS ARE PROVIDED IN THE MAIN HARDWARE KIT TO LOCK THE WHEEL BOLTS ON ALL 8 BOLT HUBS**

ITEM	PART NO	DESCRIPTION	ITEM	PART NO	DESCRIPTION
	16154	8-BOLT HUB & SPINDLE (RED) (INCLUDES ITEMS 1-8 & 11-15)	8	16156	2-1/2" AXLE SPINDLE (14-3/4)
1	88301	3/16x1-1/2 COTTER PIN	9	88298	5/8NCx4 GR5 BOLT
2	64050	2-1/2ODx1-1/16ID SPINDLE WASHER	10	88369	5/8NC LOCK NUT
3	16081	OUTER BEARING CONE (TIMKIN# 2790)	11	16083	INNER BEARING CONE (TIMKIN# 3780)
4	16082	OUTER BEARING CUP (TIMKIN# 2720)	12	16084	INNER BEARING CUP (TIMKIN# 3720)
5	41054	8-BOLT PRESSED HUB (RED) (INCLUDES ITEMS 4, 6 & 12)	13	63831	9/16NFx1-1/8 90° WHEEL BOLT
6	88143	1/4NPT GREASE FITTING	14	88299	1NF SLOTTED NUT
7	235298	2-1/2" TRIPLE LIP SEAL	15	16077	DUST CAP
7A	89458	NUT JAM 9/16-18 NF Z	16	222259	31x13.5 12 PLY 8 BLT WHEEL ASSY
				203196	15x10 WHEEL RIM
				57908	VALVE ASSEMBLY
				222088	31x13.5 12PLY TIRE

# MAIN LIFT BYPASS CYLINDER CIRCUIT

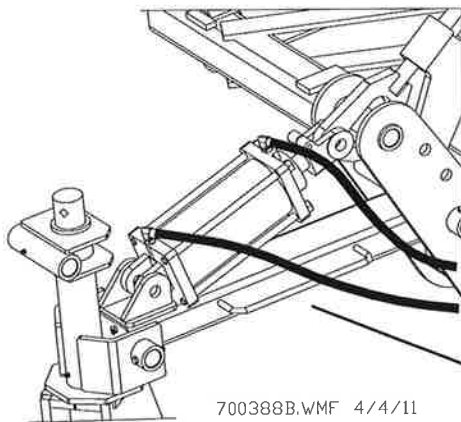
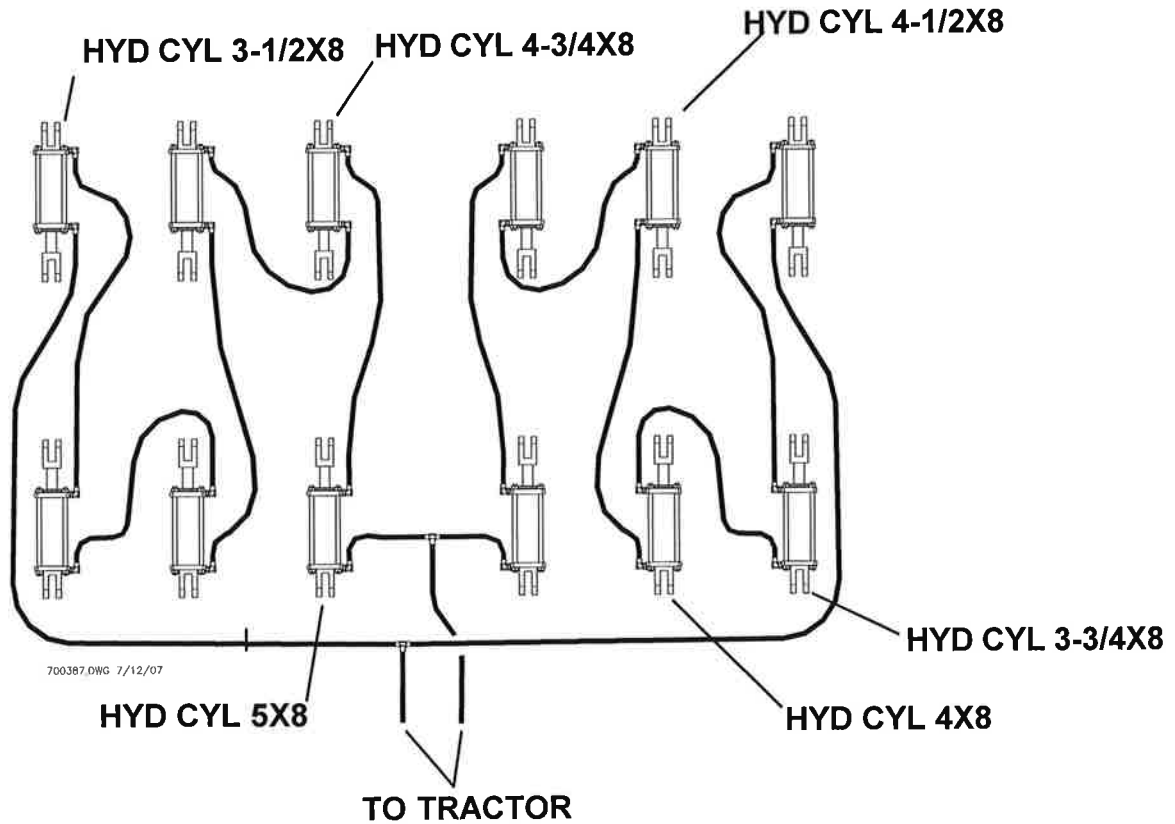

**NOTE: CYLINDERS ON FRONT LIFT AXLES AND REAR PACKER LIFTS MUST BE MOUNTED WITH RODS UP AS SHOWN. IF THE CYLINDERS HAVE PORTS ON THE SIDES THESE PORTS CAN BE UTILIZED IF REQUIRED. CHECK FOR FITTING AND HOSE INTERFERENCE BEFORE AND WHILE ACTIVATING ALL CYLINDERS. ROUTE HOSES TO CLEAR ANY OBSTRUCTIONS OR PINCH POINTS WHEN OPERATING.**

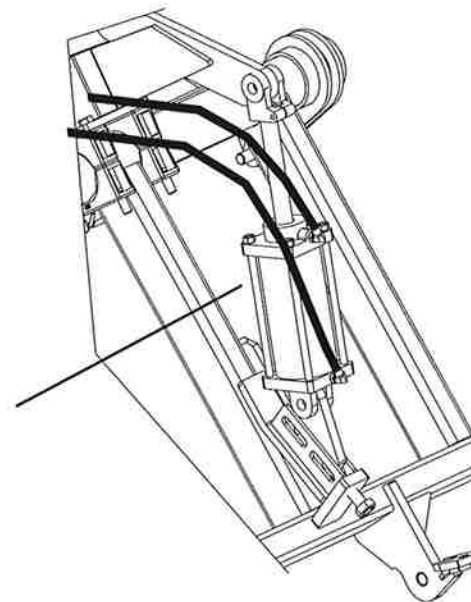

# CYLINDER LOCATIONS & SEAL KITS

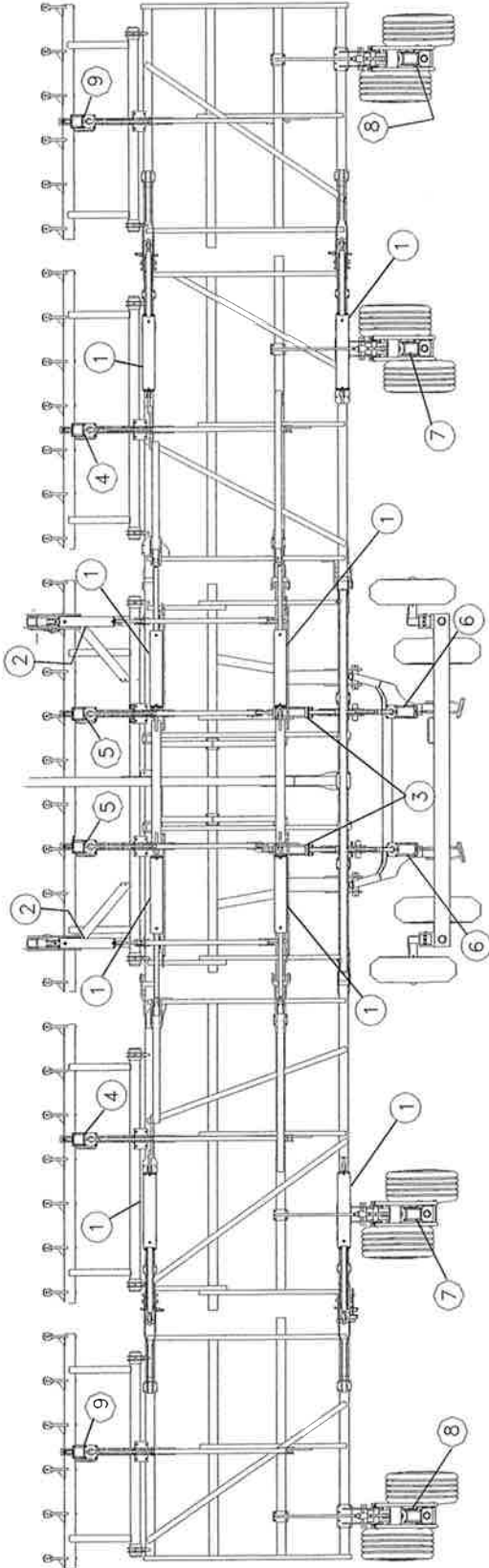

ITEM	PART NO	DESCRIPTION	QTY	SEAL KIT	DESCRIPTION
1	20966F	HYD CYL 5X30 ILP FGS #A519CY07	8	233731	SEAL KIT 5IN (FGS-SK-ACBX5Q2Q)
2	222213F1	HYD CYL 4X16 ILP #A519CY26	2	233838	SEAL KIT 4IN (FGS-SK-ACGZ4Q2Q)
3	234764	HYD CYL 4" X 12" (BLACK)	2	241670	SEAL KIT 4IN ATD BP CYL
4	241622	HYD CYL 4-1/2X8 SEQ	2	241671	SEAL KIT 4-1/2IN ATD BP CYL
5	241623	HYD CYL 4-3/4X8 SEQ	2	241672	SEAL KIT 4-3/4IN ATD BP CYL
6	241624	HYD CYL 5X8 SEQ	2	241673	SEAL KIT 5IN ATD BP CYL
7	241663	HYD CYL 4X8 WITH SPACER	2	241670	SEAL KIT 4IN ATD BP CYL
8	241664	HYD CYL 3-3/4X8 WITH SPACER	2	241669	SEAL KIT 3-3/4IN ATD BP CYL
9	241665	HYD CYL 3-1/2X8 WITH SPACER	2	241668	SEAL KIT 3-1/2IN ATD BP CYL

700538A 1-24-12

# HYDRAULIC STOP COLLARS

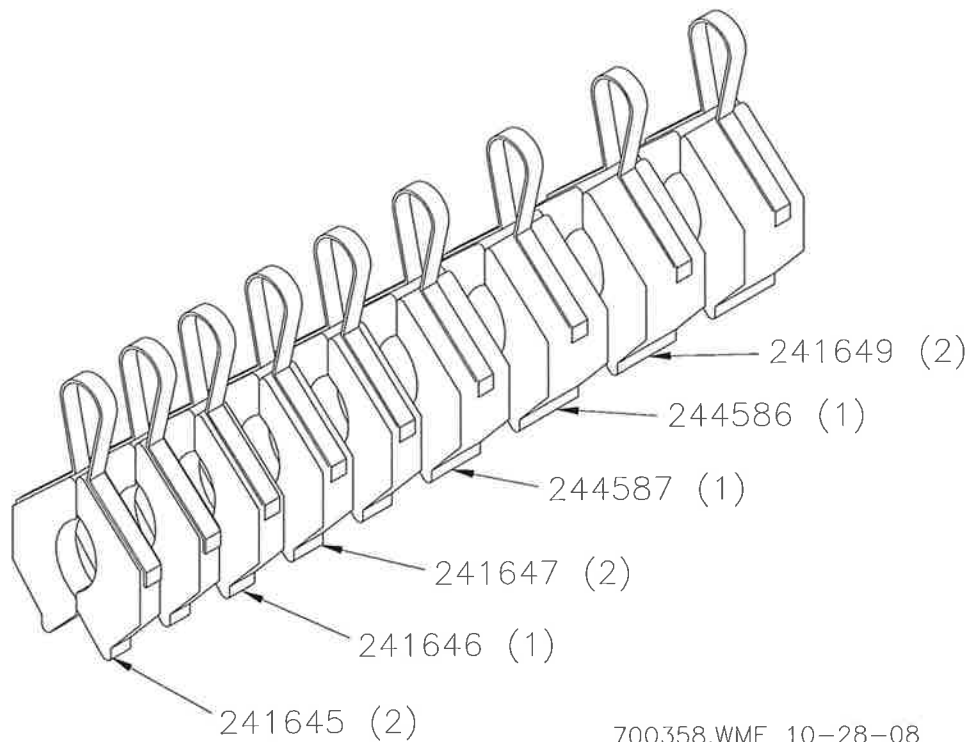

700358.WMF 10-28-08

PART NO.	DESCRIPTION	QTY/KIT
243994	<b>PAINTED STOP COLLAR KIT - CONTAINS FOLLOWING ITEMS</b>	
241645	1/2IN CYLINDER STOP (RED)	2
241646	5/8IN CYLINDER STOP (ORANGE)	1
241647	3/4IN CYLINDER STOP (YELLOW)	2
241649	1-1/2IN CYLINDER STOP (GRAY)	2
244587	1-1/4 IN CYLINDER STOP (GREEN)	1
244586	1-7/16 IN CYLINDER STOP (BLUE)	1

# HYDRAULIC STOP COLLARS COMBINATIONS

## STOP COLLAR COMBINATIONS

TOTAL DIM	TOTAL DIM			TOTAL DIM			TOTAL DIM			TOTAL DIM				
	R	R	R	R	R	R	R	R	R					
1	R	R	R	R	R	R	R	R	R	4.94	Y	Y	B	GY
1.12	R	O		R	R	R	R	R	R	5	Y	Y	GY	GY
1.25	R	Y		R	O	Y	B	O	Y	5.06	Y	Y	B	GY
1.38	O	Y		R	O	Y	GY	O	Y	5.12	Y	Y	GY	GY
1.44	B			R	B	GR		R	R	5.18	R	GN	B	GY
1.5	Y	Y		R	GY	GY		R	R	5.25	R	GN	GY	GY
1.62	R	R	O	O	B	GY		R	R	5.31	R	O	Y	B
1.75	R	G		O	GY	GY		R	R	5.38	R	O	Y	GY
1.88	R	O	Y	Y	B	GY		R	R	5.44	R	Y	Y	B
1.94	R	B		Y	GY	GY		R	R	5.5	R	Y	Y	GY
2	R	GR		R	R	O	Y	B	O	5.56	R	Y	Y	B
2.06	O	B		R	R	O	Y	GY	O	5.62	R	O	Y	GY
2.12	O	GY		R	R	B	GY		Y	5.69	Y	GN	B	GY
2.18	Y	N		R	R	GY	GY		Y	5.75	Y	GN	GY	GY
2.25	Y	GY		R	O	B	GY		R	5.81	R	O	GN	B
2.38	R	O	GN	R	O	GY	GY		R	5.88	R	O	GN	GY
2.44	R	R	B	R	GN	N	GY		R	5.94	R	Y	GN	GY
2.5	R	R	GY	R	GN	GY			R	6	R	Y	GN	GY
2.56	R	O	B	O	Y	B	GY		R	6.06	R	O	Y	B
2.62	R	O	GY	O	Y	GY	GY		R	6.12	R	O	Y	GY
2.69	R	Y	B	Y	Y	B	GY		R	6.18	R	Y	GN	B
2.75	R	Y	GR	Y	Y	GY	GY		R	6.25	R	Y	GN	GY
2.81	O	Y	B	R	R	O	B	GY	O	6.31	O	Y	GN	B
2.88	O	Y	GY	R	R	O	GY	GY	O	6.38	O	Y	GN	GY
2.94	B	GY		R	R	Y	GY	GY	Y	6.44	Y	GN	GY	GY
3	GY	GY		R	R	Y	GY	GY	O	6.56	O	Y	B	GY
3.06	R	R	O	R	O	Y	B	GY						
3.12	R	R	O	R	O	Y	GY	GY						

700453.WMF 1-5-08

GREEN	GN	1.25
BLUE	B	1.438
GRAY	GY	1.5

RED	R	0.5
ORANGE	O	0.625
YELLOW	Y	0.75

# HOSE ROUTING - 50'/60' TRANSPORT LIFT

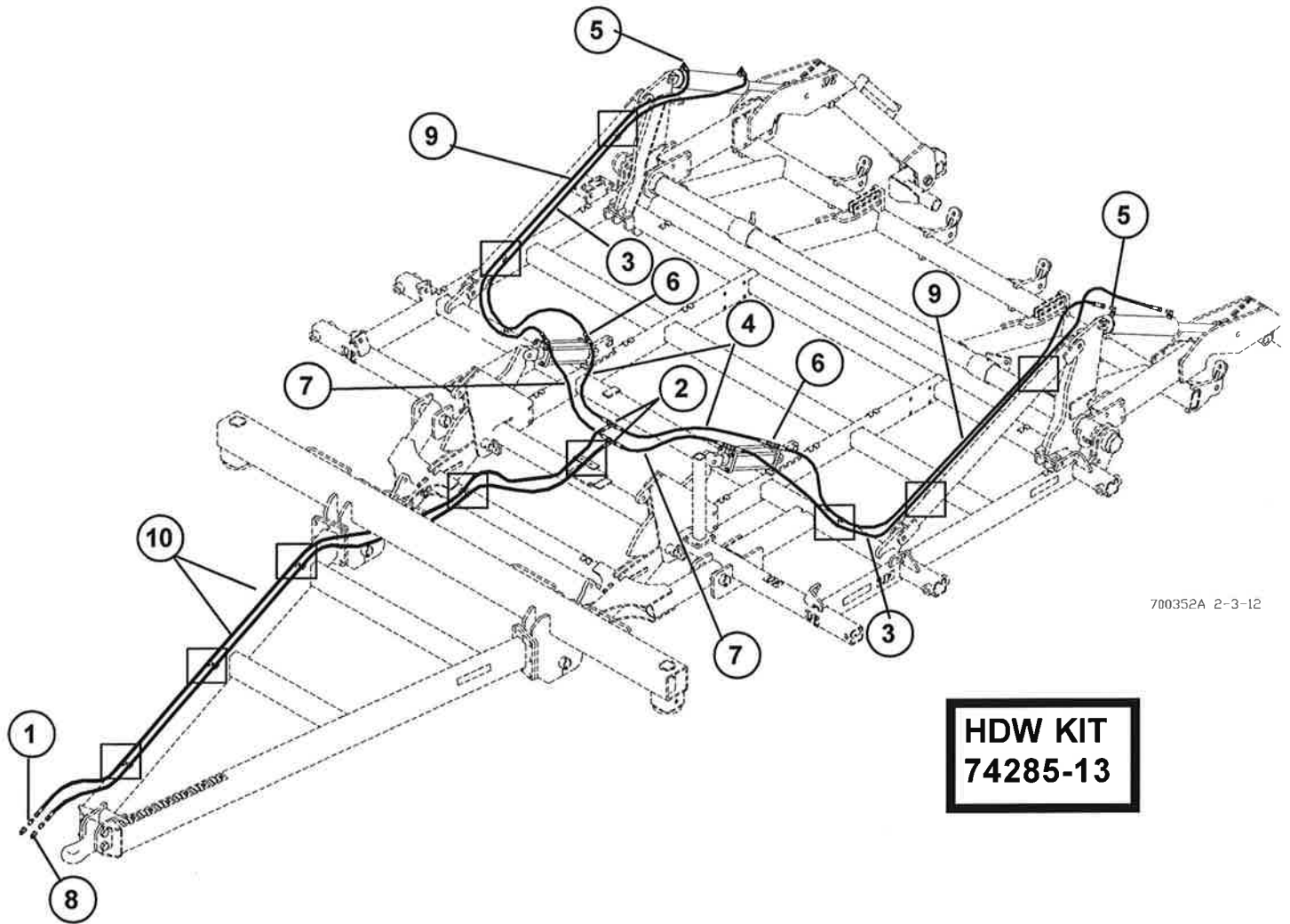

700352A 2-3-12

**HDW KIT  
74285-13**

Hose are equipped with JIC fittings, tighten to seal, do not overtighten.  
Cylinder port require O-ring fittings, tighten to compress the O-ring to seal.  
Pipe thread fitting require some type of thread sealant to seal.

ITEM	PART NO	DESCRIPTION	QTY
1	13234	ADP 8MJ X 8MPT	2
2	13238	TEE 8MJ X 8MJ X 8MJ	2
3	13484	HSE 3KPSI 3/8X156 8FJX-8FJX	2
4	15515	HSE 3KPSI 3/8X62 8FJX-8FJX	2
5	25580	ELB 8MORB X 8MJ	4
6	56534	TEE 8MJ X 8MJ X 8MORB	4
7	56539	HSE 3KPSI 3/8X50 8FJX-8FJX	2
8	60640	QUICK DISCONNECT COUPLER	2
9	67634	HSE 3KPSI 3/8X132 8FJX-8FJX	2
10	237264	HSE 3KPSI 1/2X234 8FJX-8FJX	2

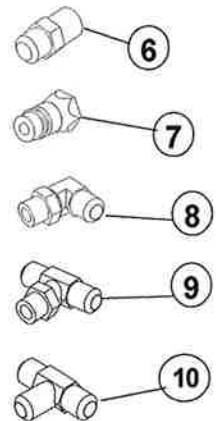

# HOSE ROUTING - 15.2 M (50FT) MAIN LIFT

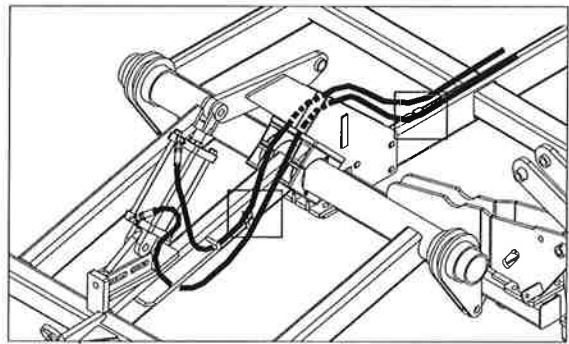
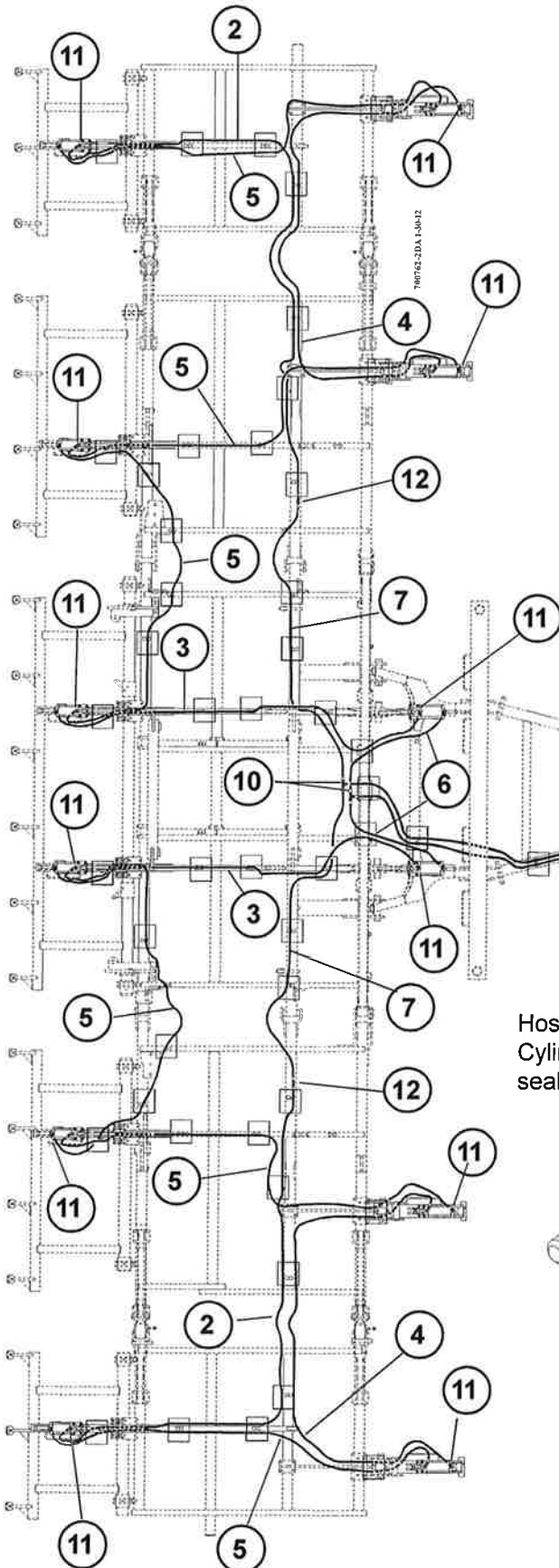

700762-2DC 1-30-12

Refer to cylinder hose routing and cylinder location information on Page 59. Route hoses approximately as shown, retain with c;lamps and hardware to hose mounts. Note: hoses and fittings are not to scale.

□ Box indicates location of hose mounting point

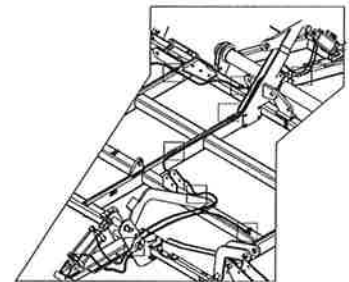

700762-2DB 1-30-12

Hose are equipped with JIC fittings, tighten to seal, do not overtighten. Cylinder port require O-ring fittings, tighten to compress the O-ring to seal. Pipe thread fittings require some type of thread sealant to seal.

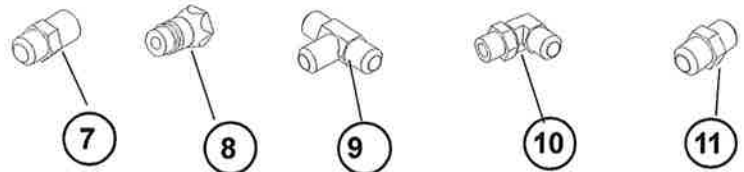

**HDW KIT  
79973-11**



# HOSE ROUTING - 15.2 M (50FT) MAIN LIFT

ITEM	PART NO.	DESCRIPTION	QTY
1	237264	HSE 3KPSI 1/2X234 8FJX-8FJX	2
2	233688	HSE 3KPSI 3/8X252 8FJX-8FJX	2
3	233689	HSE 3KPSI 3/8X180 8FJX-8FJX	4
4	234939	HSE 3KPSI 3/8X220 8FJX-8FJX	2
5	234947	HSE 3KPSI 3/8X194 8FJX-8FJX	6
6	15515	HSE 3KPSI 3/8X62 8FJX-8FJX	2
7	13234	ADP 8MJ X 8MPT	28
8	60640	QUICK DISCONNECT COUPLER	2
9	13238	TEE 8MJ X 8MJ X 8MJ	2
10	25580	ELD 8MORB X 8MJ	24
11	13239	APD UNION 8MJ X8MJ	2

## HOSE CLAMPING - ALL SYSTEMS & MODELS

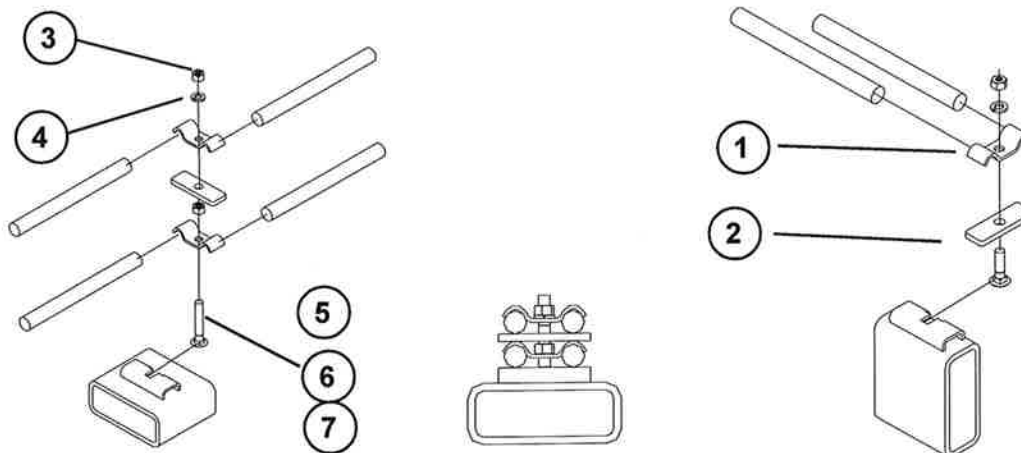

700798 1/30/12

**ATTACH HOSES AS SHOWN. ROUTE ALL HOSES BEFORE ANY HARDWARE IS SECURED. QUANTITY AND COMBINATION OF HARDWARE VARIES BY MODEL**

ITEM	PART NO	DESCRIPTION
1	13215	TUBE CLAMP
2	15543	BASE PLATE - ZINC
3	88103	NUT HEX 3/8-16NC 5Z
4	88362	WSHR HLK 3/8ID Z
5	89375	BLT CRG 3/8-16NC X 1-1/2 5Z
6	89473	BLT CRG 3/8-16NC X 2-1/2 5Z
7	89494	BLT CRG 3/8-16NC X 6 5Z

# HOSE ROUTING - 15.2 M (50FT) WING FOLD

SECURE VALVE TO FRONT  
WING REST PLATE

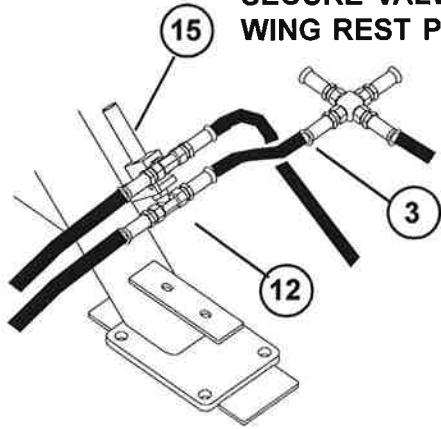

700796-1 1-30-12

**HDW KIT  
79973-12**

700796.VMF5/12

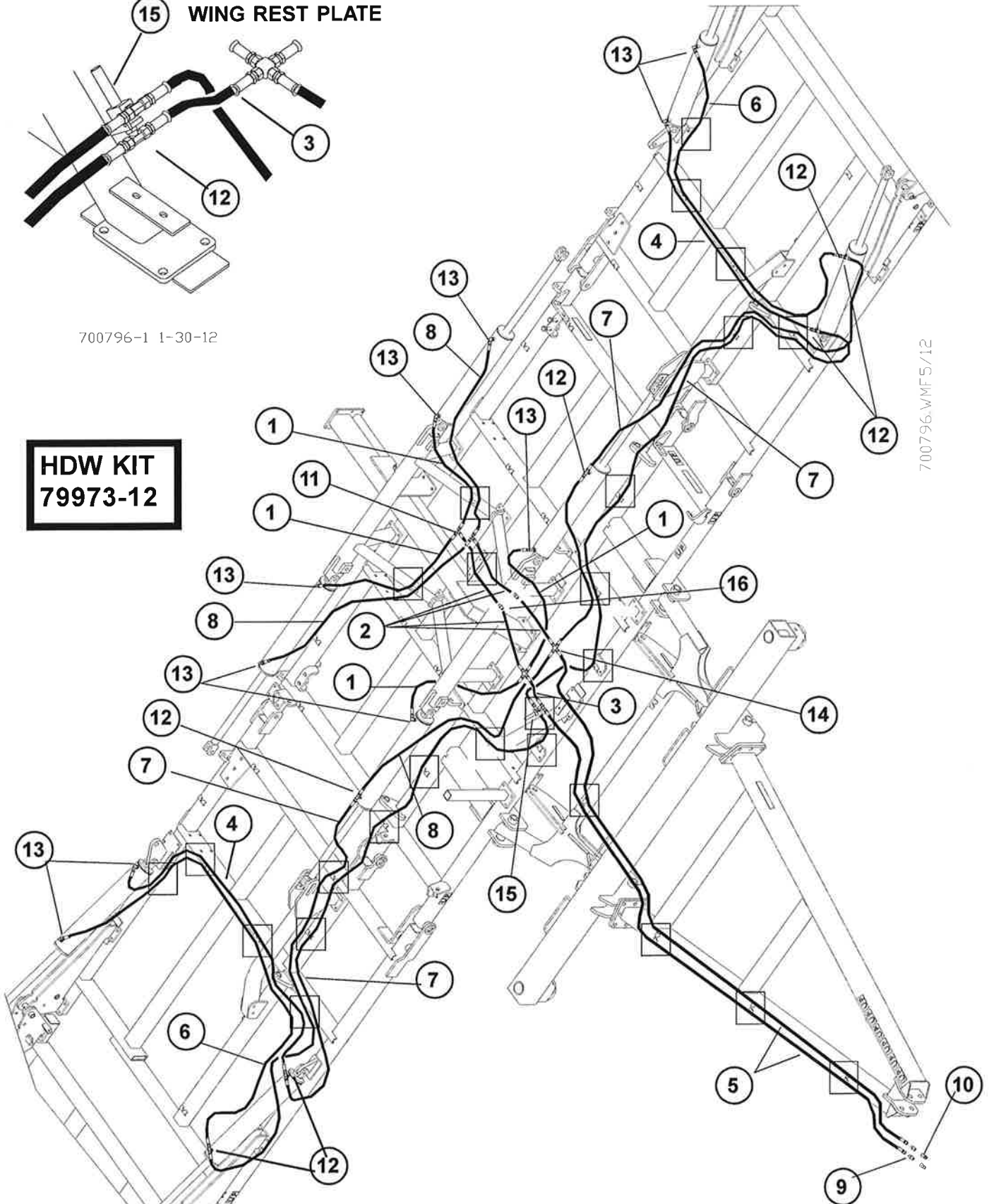

# HOSE ROUTING - 15.2 M (50FT) WING FOLD

Set sequence valve (15) by adjusting valve screw to control the extension of the outer wing fold cylinders. Turn adjust screw counter-clockwise from factory setting to retard the inner wing fold

Hose are equipped with JIC fittings, tighten to seal, do not overtighten. Cylinder port require O-ring fittings, tighten to compress the O-ring to seal. Pipe thread fitting require some type of thread sealant to seal.

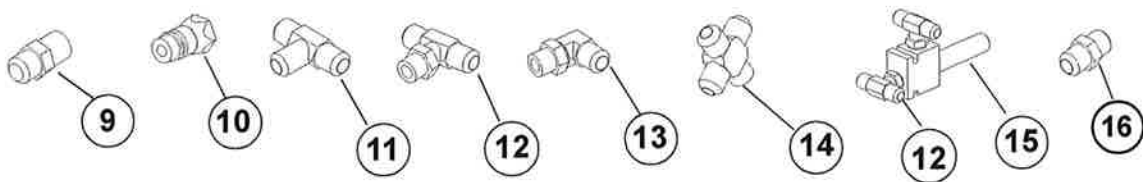

ITEM NO.	PART NO.	DESCRIPTION	QTY
1	56539	HSE 3KPSI 3/8X50 8FJX-8FJX	4
2	240261	HSE 3KPSI 1/2X36 8FJX-8FJX	4
3	239088	HSE 3KPSI 1/2X18 8FJX-8FJX	1
4	13483	HSE 3KPSI 3/8X120 8FJX-8FJX	2
5	237264	HSE 3KPSI 1/2X234 8FJX-8FJX	2
6	233689	HSE 3KPSI 3/8X180 8FJX-8FJX	2
7	59909	HSE 3KPSI 3/8X168 8FJX-8FJX	4
8	13268	HSE 3KPSI 3/8X78 8FJX-8FJX	4
9	13234	ADP 8MJ X 8MPT	2
10	60640	QUICK DISCONNECT COUPLER	2
11	13238	TEE 8MJ X 8MJ X 8MJ	2
12	56534	TEE 8MJ X 8MJ X 8MORB	8
13	25580	ELB 8MORB X 8MJ	10
14	15910	CROSS 8MJ X 8MJ X 8MJ X 8MJ	2
15	65870	SEQUENCE VALVE	1
16	13239	UNION 8MJ X 8MJ	2

# HOSE ROUTING - 18.3 M (60FT) MAIN LIFT

LEFT SIDE SHOWN

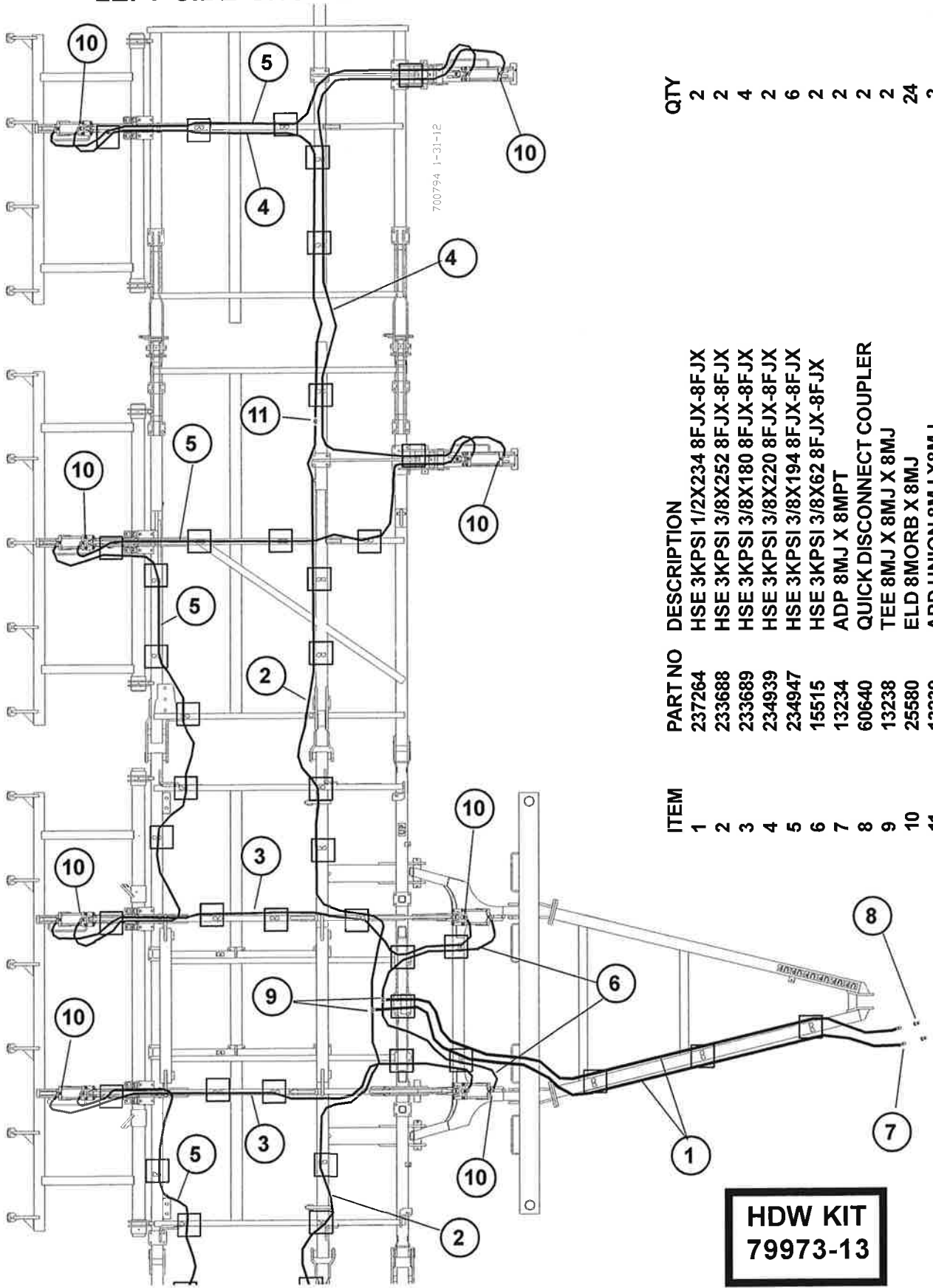

ITEM	PART NO	DESCRIPTION	QTY
1	237264	HSE 3KPSI 1/2X234 8FJX-8FJX	2
2	233688	HSE 3KPSI 3/8X252 8FJX-8FJX	2
3	233689	HSE 3KPSI 3/8X180 8FJX-8FJX	4
4	234939	HSE 3KPSI 3/8X220 8FJX-8FJX	2
5	234947	HSE 3KPSI 3/8X194 8FJX-8FJX	6
6	15515	HSE 3KPSI 3/8X62 8FJX-8FJX	2
7	13234	ADP 8MJ X 8MPT	2
8	60640	QUICK DISCONNECT COUPLER	2
9	13238	TEE 8MJ X 8MJ X 8MJ	2
10	25580	ELD 8MORB X 8MJ	24
11	13239	APD UNION 8MJ X8MJ	2

**HDW KIT  
79973-13**

Refer to cylinder hose routing and cylinder location information on Page 59. Route hoses approximately as shown, retain with clamps and hardware to hose mounts. Note: hoses and fittings are not to scale.

# HOSE ROUTING - 18.3 M (60FT) MAIN LIFT

RIGHT SIDE SHOWN

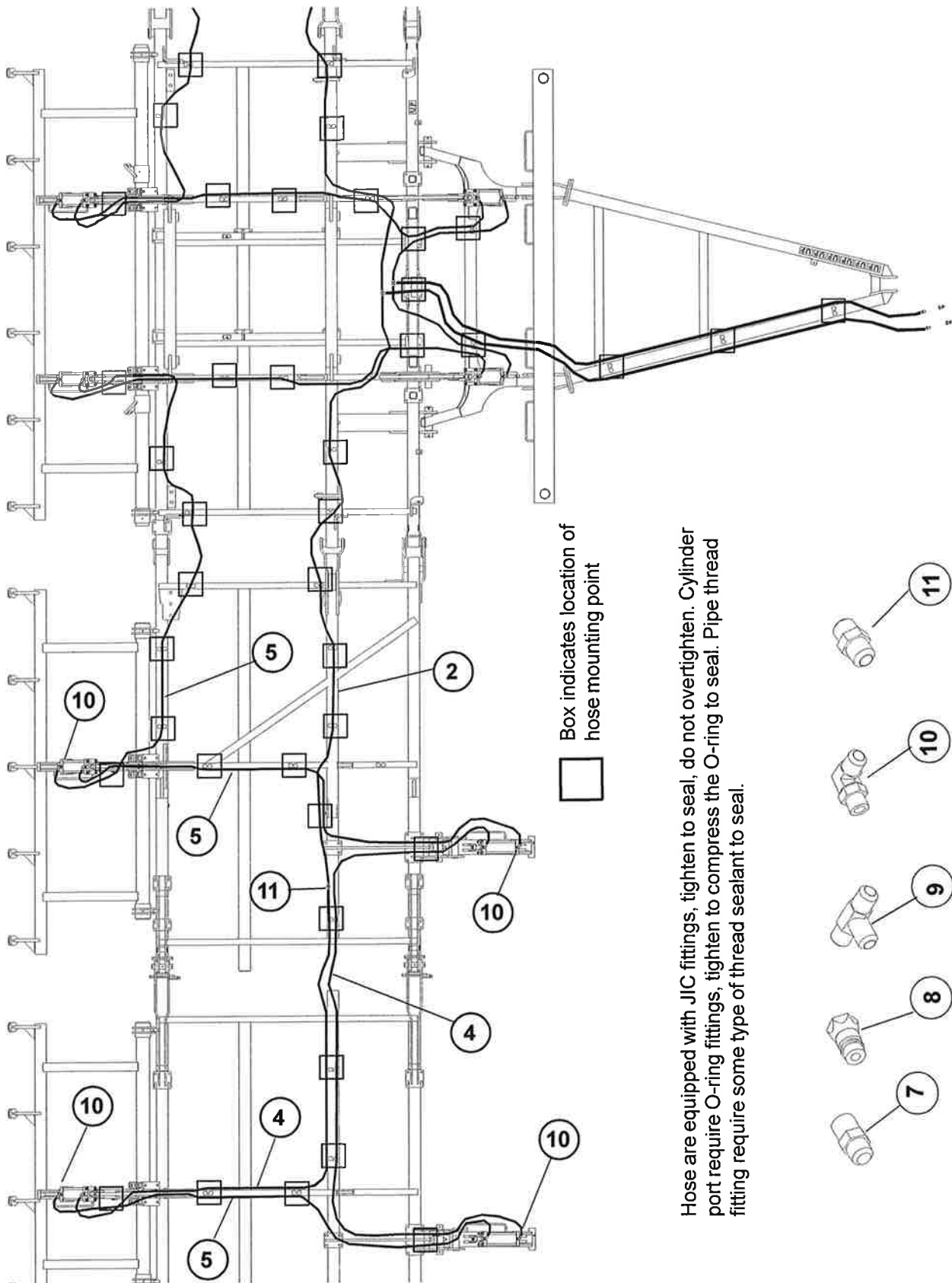

Box indicates location of hose mounting point

Hose are equipped with JIC fittings, tighten to seal, do not overtighten. Cylinder port require O-ring fittings, tighten to compress the O-ring to seal. Pipe thread fitting require some type of thread sealant to seal.

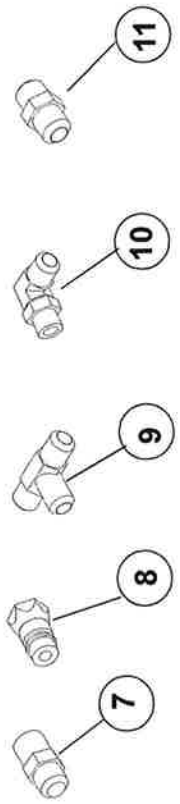

# HOSE ROUTING - 18.3 M (60FT) WING FOLD

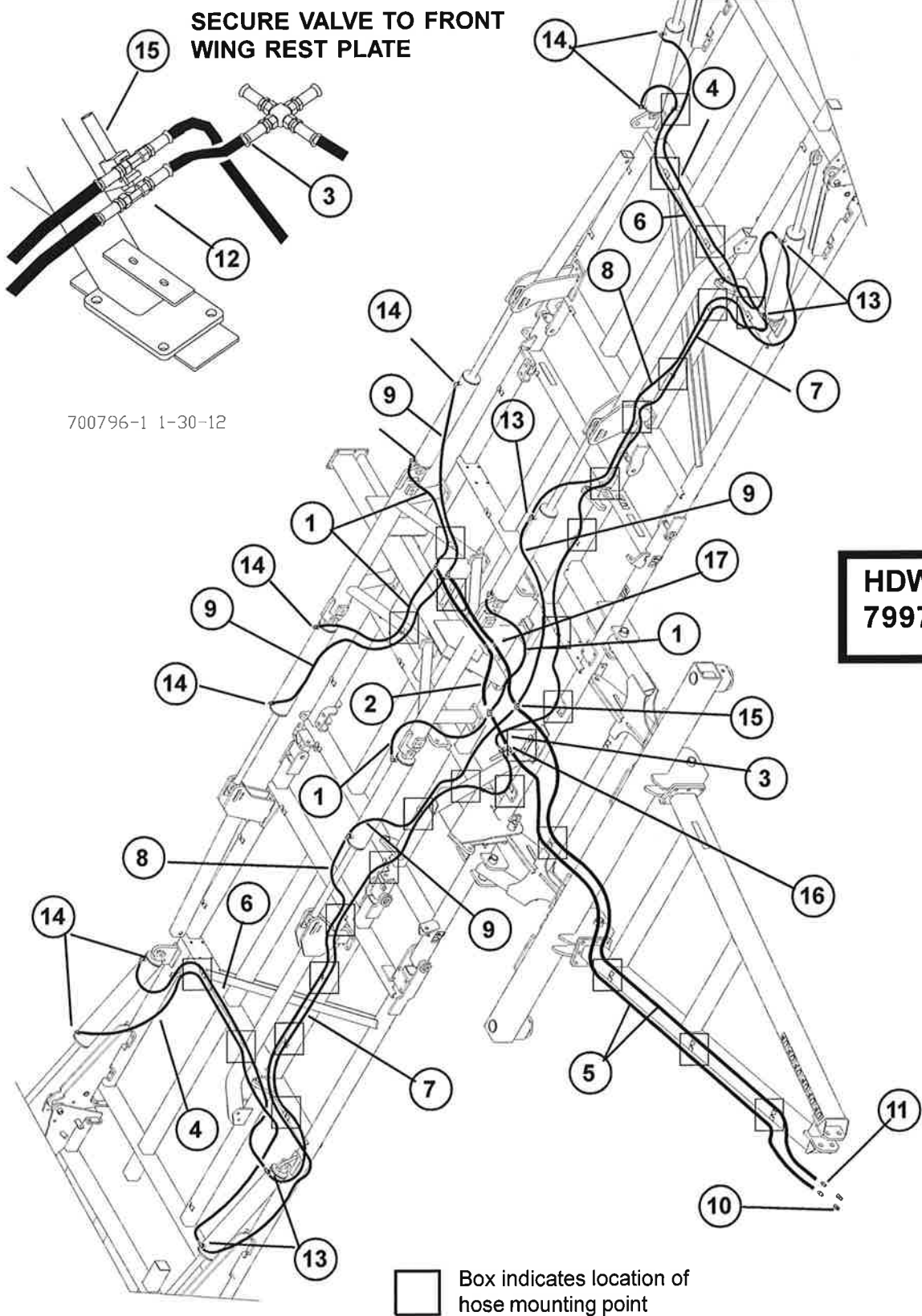

# HOSE ROUTING - 18.3 M (60FT) WING FOLD

Set sequence valve (15) by adjusting valve screw to control the extension of the outer wing fold cylinders. Turn adjust screw counter-clockwise from factory setting to retard the inner wing fold

Hose are equipped with JIC fittings, tighten to seal, do not overtighten. Cylinder port require O-ring fittings, tighten to compress the O-ring to seal. Pipe thread fitting require some type of liquid thread sealing compound.

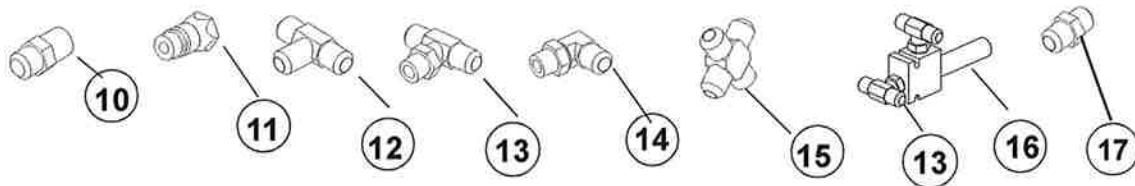

ITEM	PART NO	DESCRIPTION	QTY
1	56539	HSE 3KPSI 3/8X50 8FJX-8FJX	4
2	240261	HSE 3KPSI 1/2X36 8FJX-8FJX	4
3	239088	HSE 3KPSI 1/2X18 8FJX-8FJX	1
4	13483	HSE 3KPSI 3/8X120 8FJX-8FJX	2
5	237264	HSE 3KPSI 1/2X234 8FJX-8FJX	2
6	233689	HSE 3KPSI 3/8X180 8FJX-8FJX	2
7	234939	HSE 3KPSI 3/8X220 8FJX-8FJX	2
8	234947	HSE 3KPSI 3/8X194 8FJX-8FJX	2
9	13268	HSE 3KPSI 3/8X78 8FJX-8FJX	4
10	13234	ADP 8MJ X 8MPT	2
11	60640	QUICK DISCONNECT COUPLER	2
12	13238	TEE 8MJ X 8MJ X 8MJ	2
13	56534	TEE 8MJ X 8MJ X 8MORB	8
14	25580	ELB 8MORB X 8MJ	10
15	15910	CROSS 8MJ X 8MJ X 8MJ X 8MJ	2
16	65870	SEQUENCE VALVE	1
17	13239	UNION 8MJ X 8MJ	2

# HOSE ROUTING - 50/60FT REAR SEEDER SUPPLY

**HDW KIT  
74285-15**

SECURE HOSES TO HOSE BRACKETS  
SPACED ALONG REAR HITCH TUBE WITH  
CLAMPS OR PLASTIC TIES.

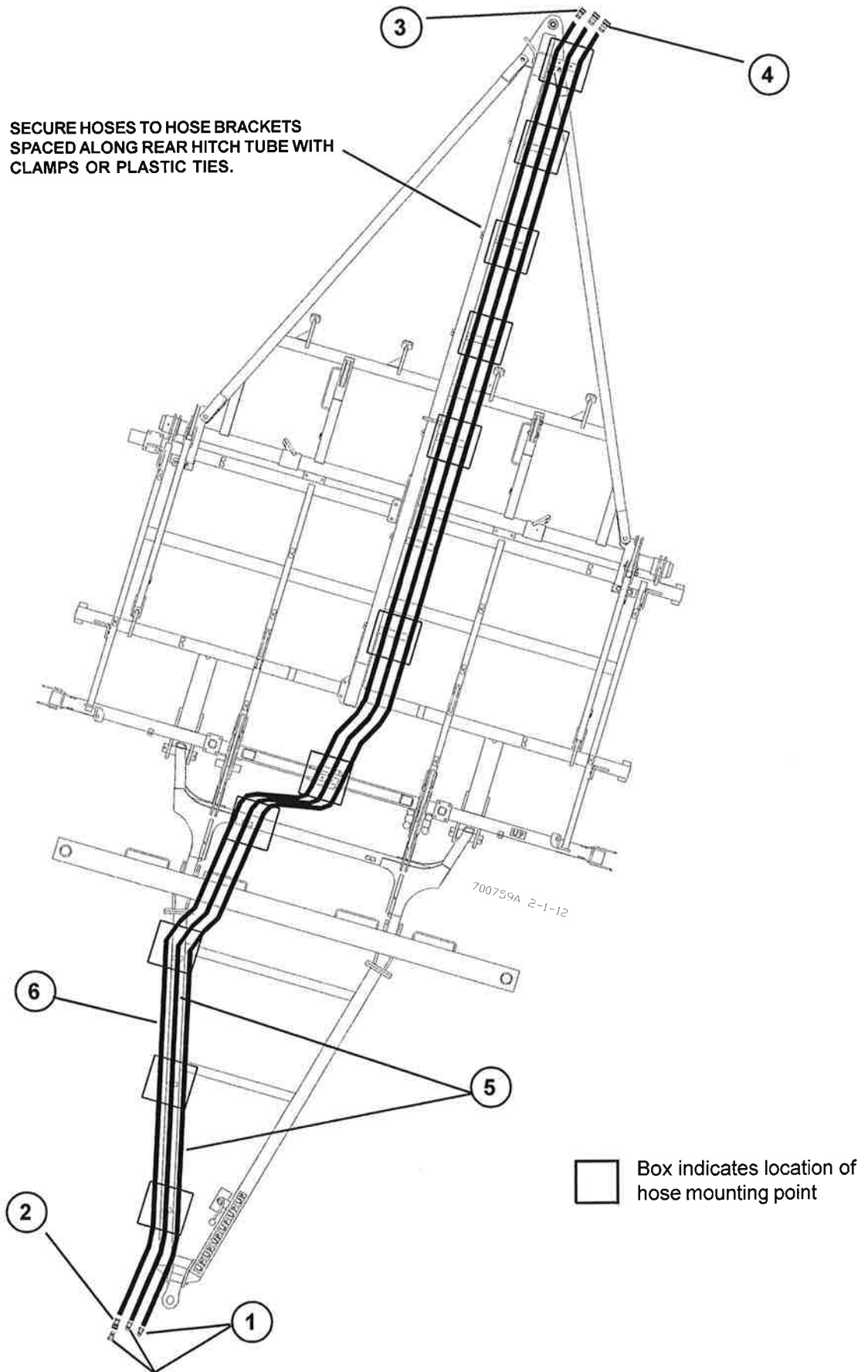



# HOSE ROUTING - 50/60FT REAR SEEDER SUPPLY

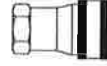

**3/4 FEMALE COUPLER  
240301**

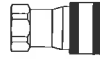

**1/2 FEMALE COUPLER  
239899**



**QUICK DISCONNECT MALE  
COUPLER - 60640**



**1/2 FEMALE PIONEER  
COUPLER - 236170**

ITEM	PART NO	DESCRIPTION	QTY
1	60640	QUICK DISCONNECT COUPLER	3
2	236170	DOUBLE ACTING FEMALE CPLR (4250-4P)	1
3	239899	1/2 FEMALE QUICK COUPLER	1
4	240301	3/4 QUICK FEMALE COUPLER	2
5	241747	HSE 3KPSI 3/4X456 8MPT-12MPT	2
6	241748	HSE 3KPSI 1/2X456 8MPT-8MPT	1

**These hoses are equipped with male pipe threads. Pipe thread fitting require some type of liquid thread sealant to seal. Route hoses as shown, secure with hose brackets or plastic ties as required.**

# RIGHT SIDE SHANK SPACINGS - 15.2 M (50- FT)

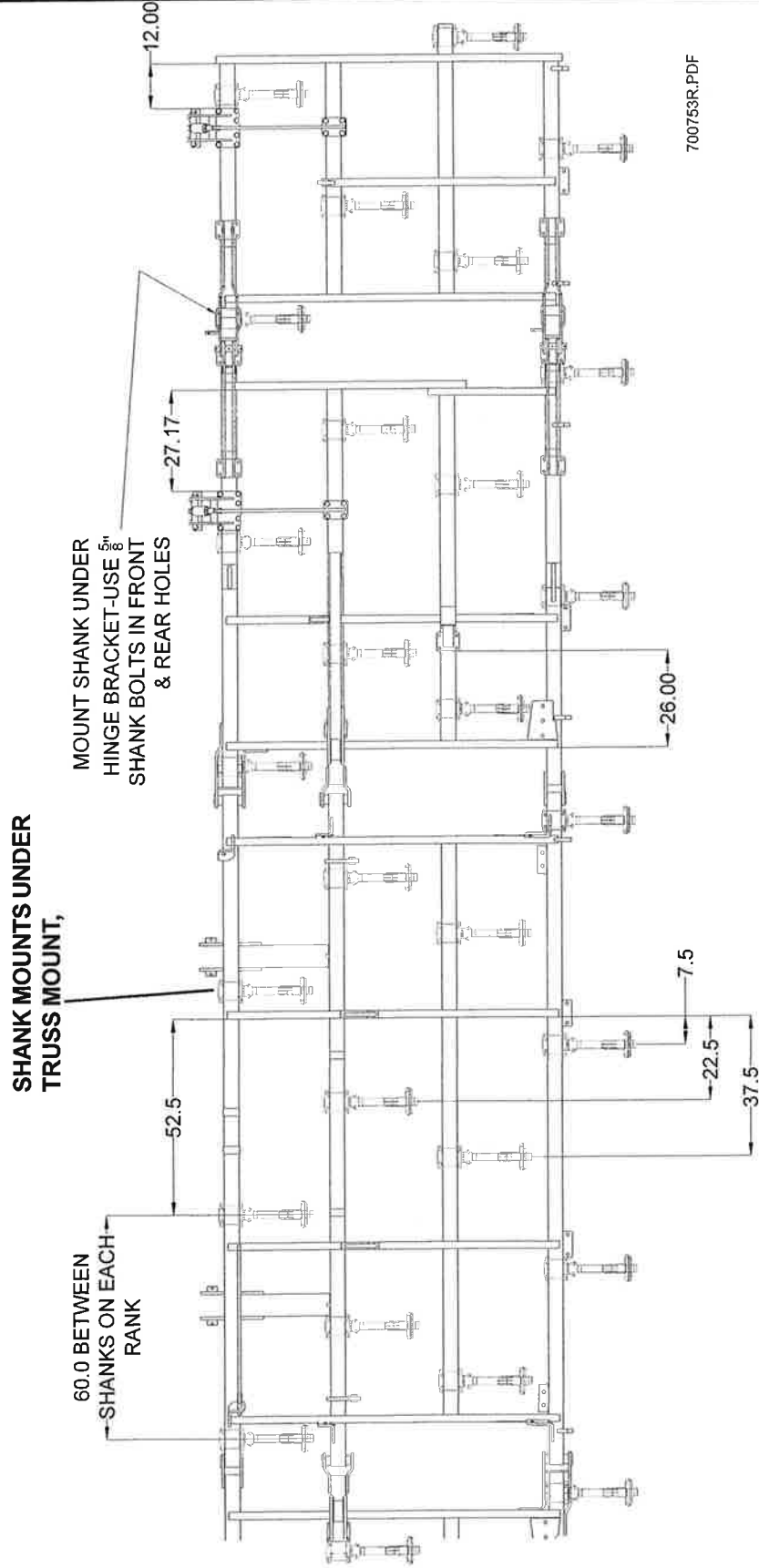

SHANKS MAY NEED TO SHIFTED Laterally FOR MOUNTING AND TRIP SPRING CLEARANCE

# LEFT SIDE SHANK SPACINGS - 15.2 M (50- FT)

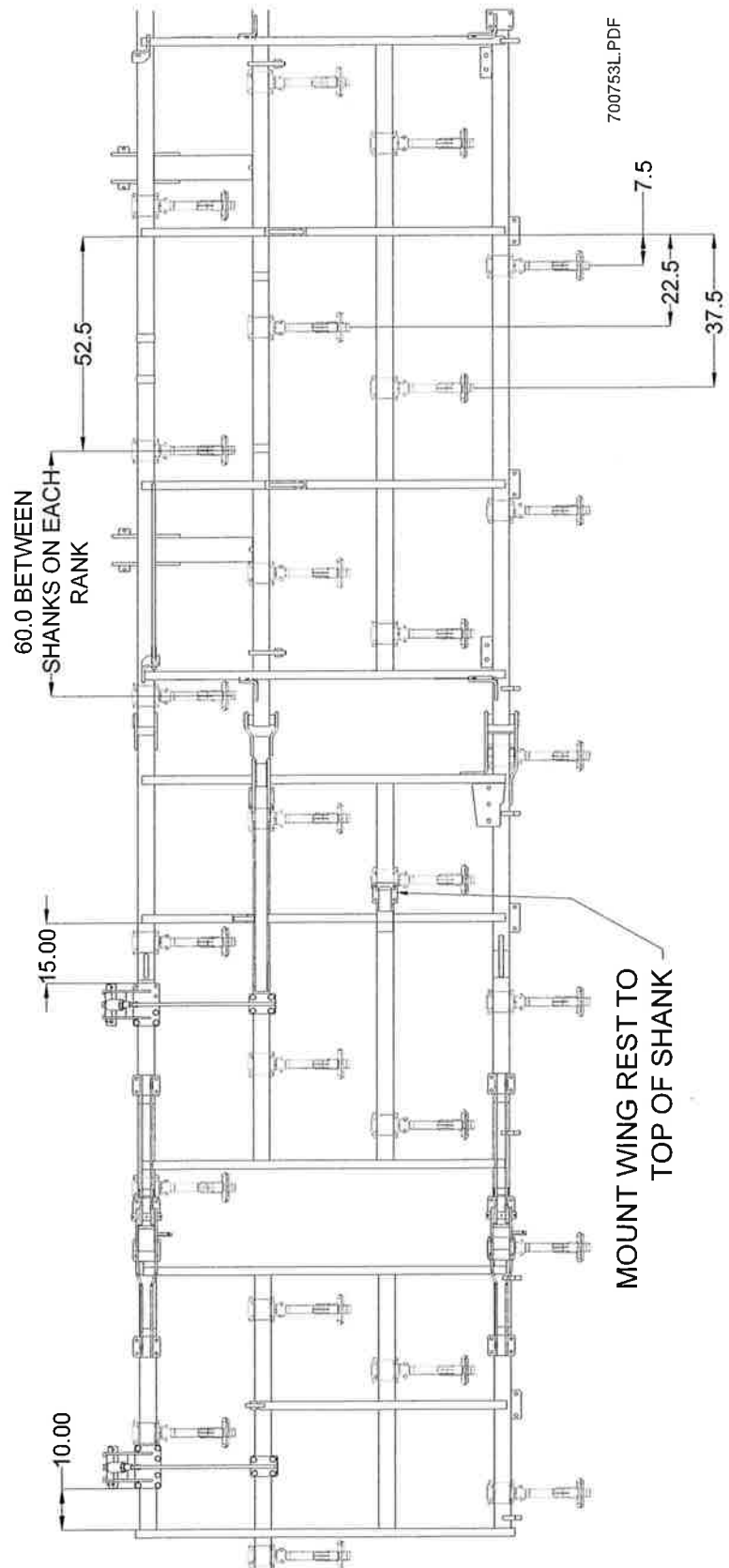

# RIGHT SIDE SHANK SPACINGS - 18.3 M (60FT)

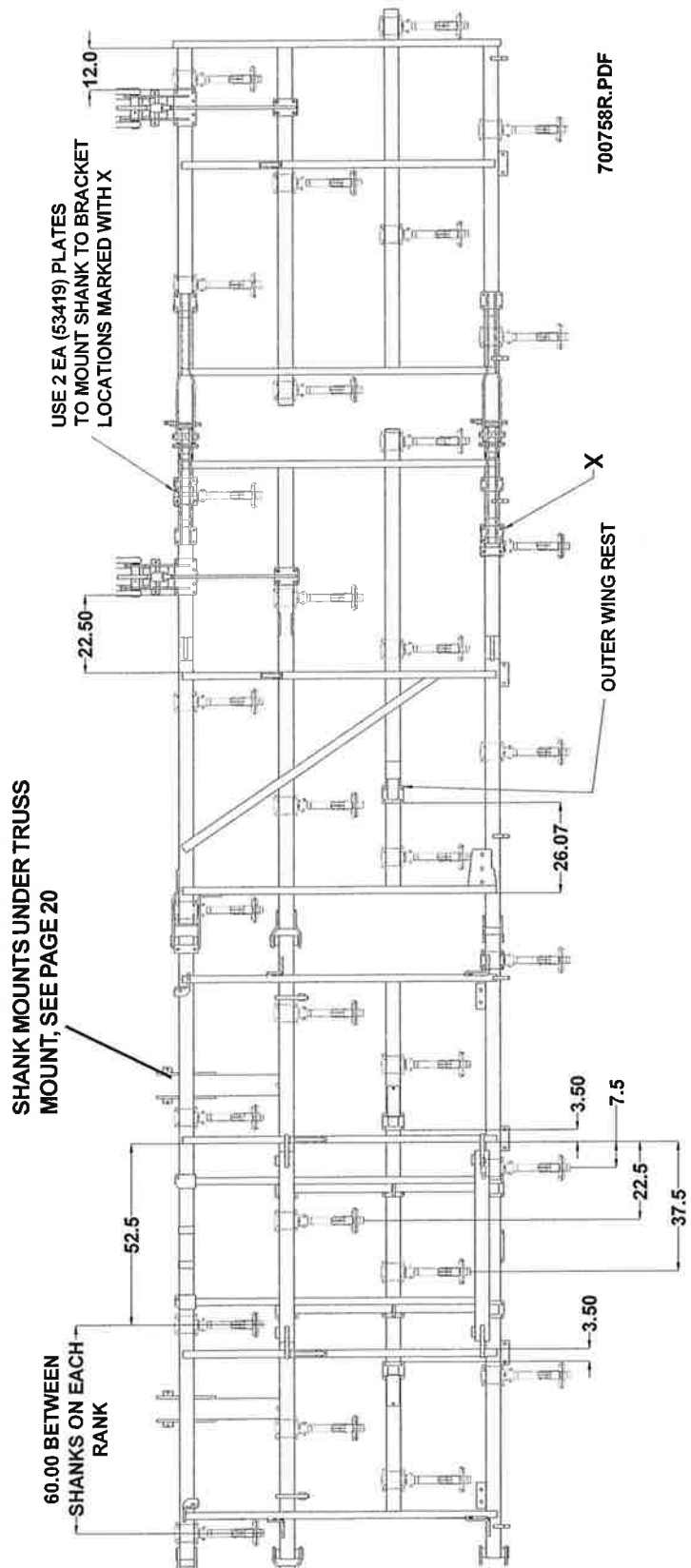

SHANKS MAY NEED TO SHIFTED Laterally FOR MOUNTING AND TRIP SPRING CLEARANCE

# LEFT SIDE SHANK SPACINGS - 18.3 M (60FT)

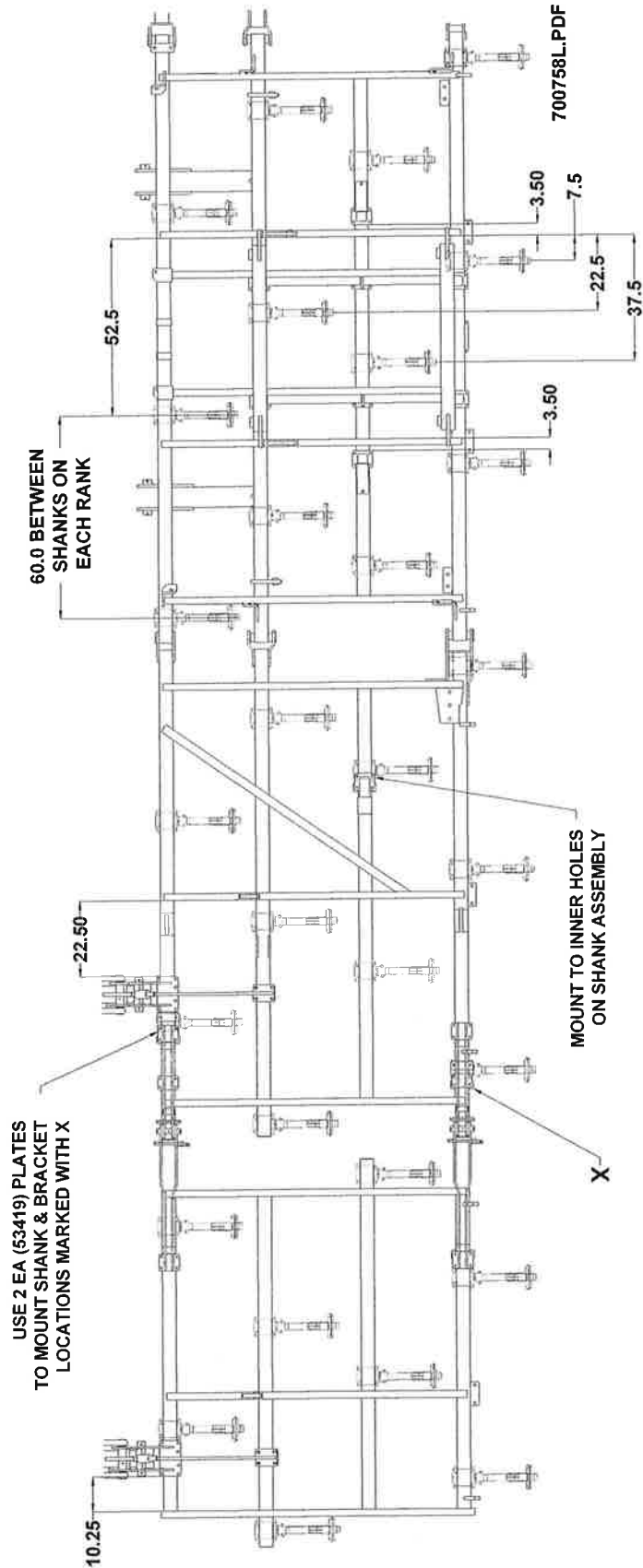

SHANKS MAY NEED TO SHIFTED Laterally FOR MOUNTING AND TRIP SPRING CLEARANCE

# GREASE FITTING LOCATION/SERVICE INTERVAL

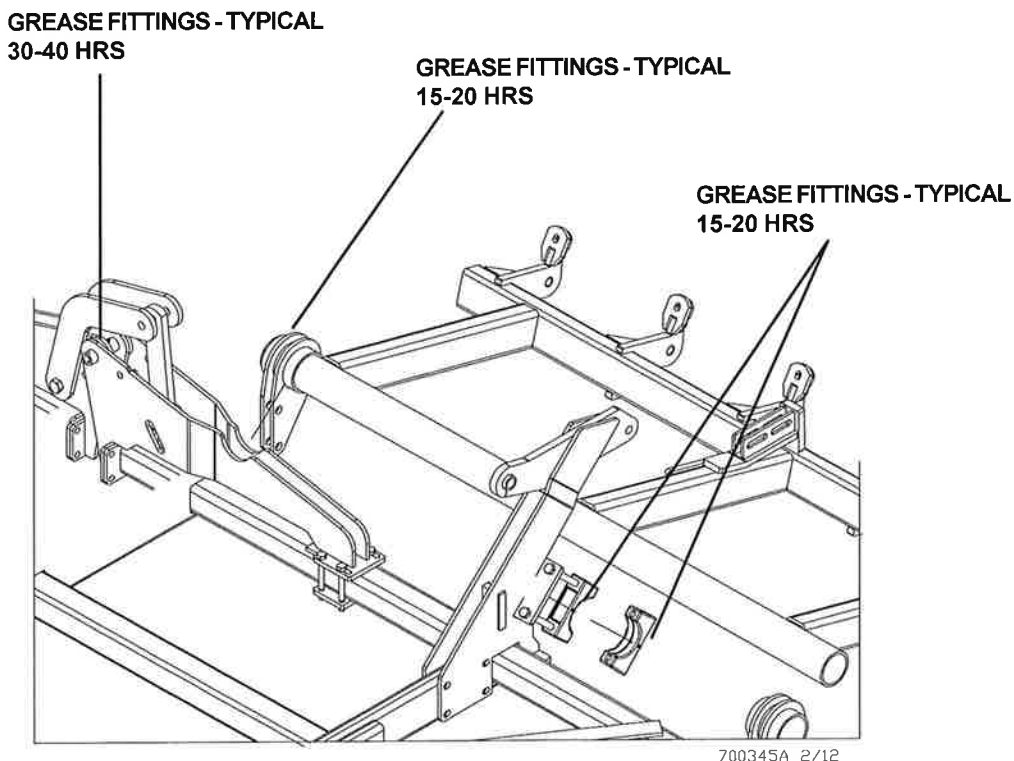
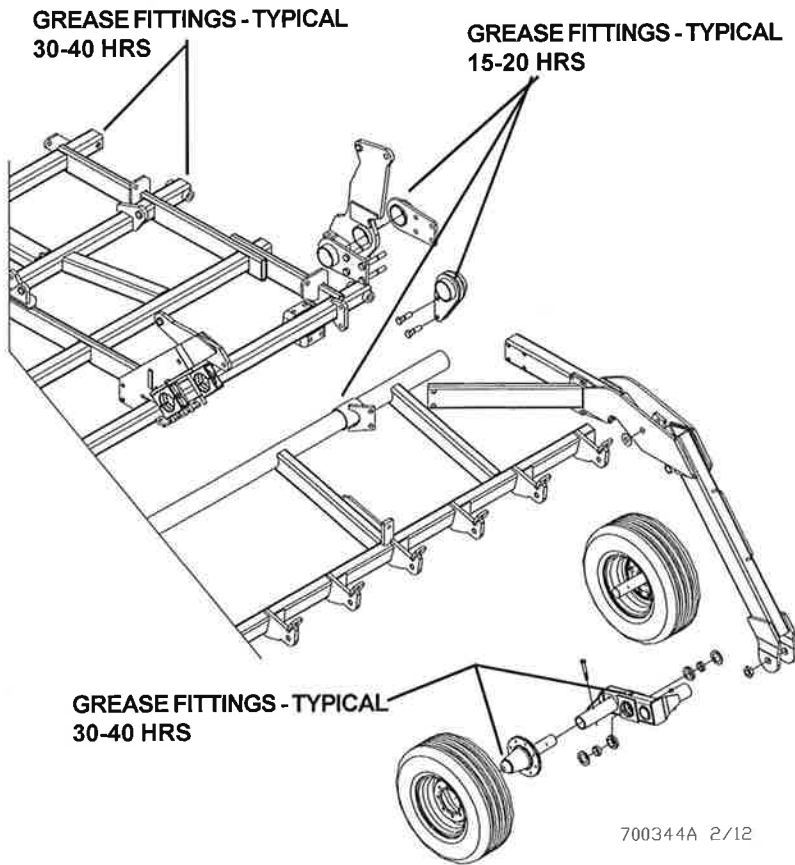

# GREASE FITTING LOCATION/SERVICE INTERVAL

HUB & SPINDLES ARE NOT FULLY FILLED WITH GREASE, REGULAR GREASING THROUGH THE GREASE FITTING WILL ONLY MINIMALLY INCREASE OR MAINTAIN THE LEVEL OF GREASE IN THE HUB.

DISASSEMBLE AND REPACK ALL WALKER AND HUB & SPINDLE BEARINGS AT END OF SEASON

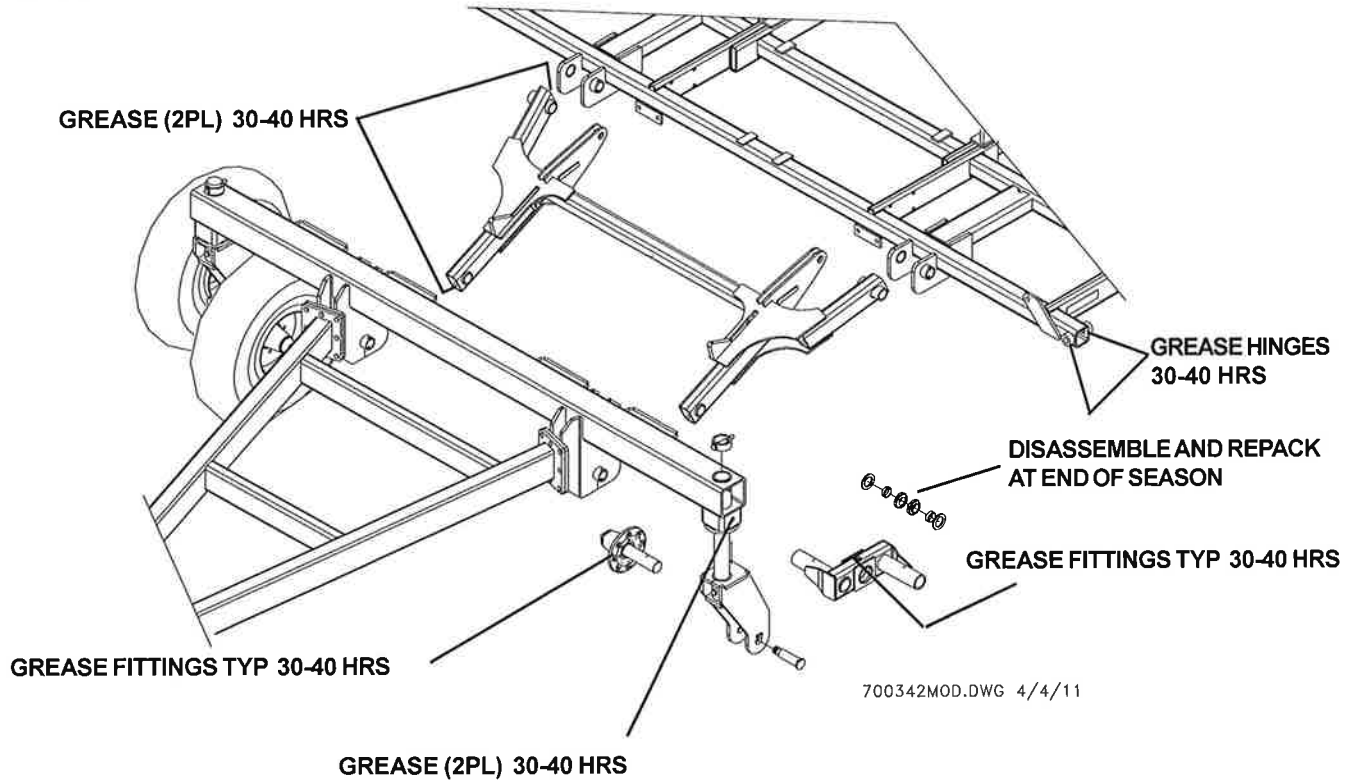

Check walker spindle nut and adjust to a heavy drag after the first 40 hrs of use and monthly thereafter.

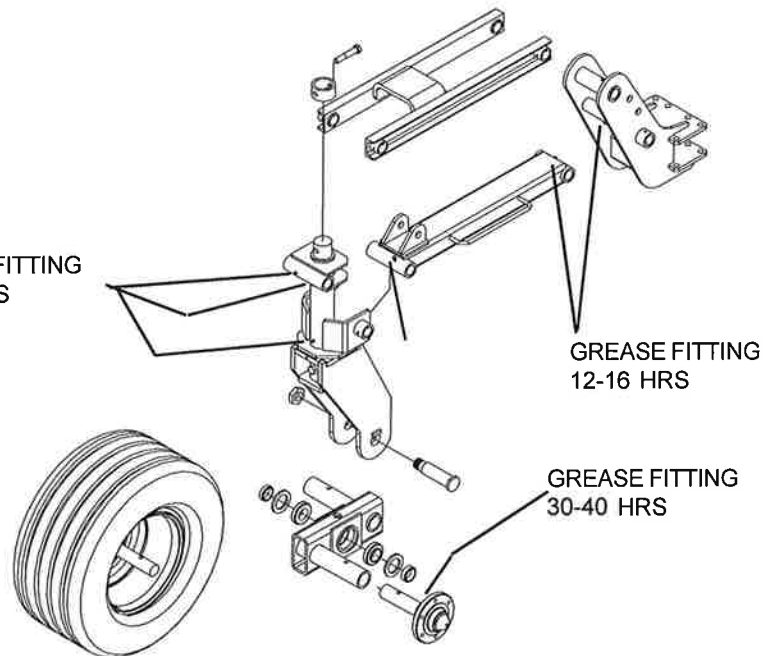

Check wheel hub and spindle nut and adjust to a moderate drag after the first 40 hrs of use and monthly thereafter. Repack bearings at end of season.

# DECAL PLACEMENT

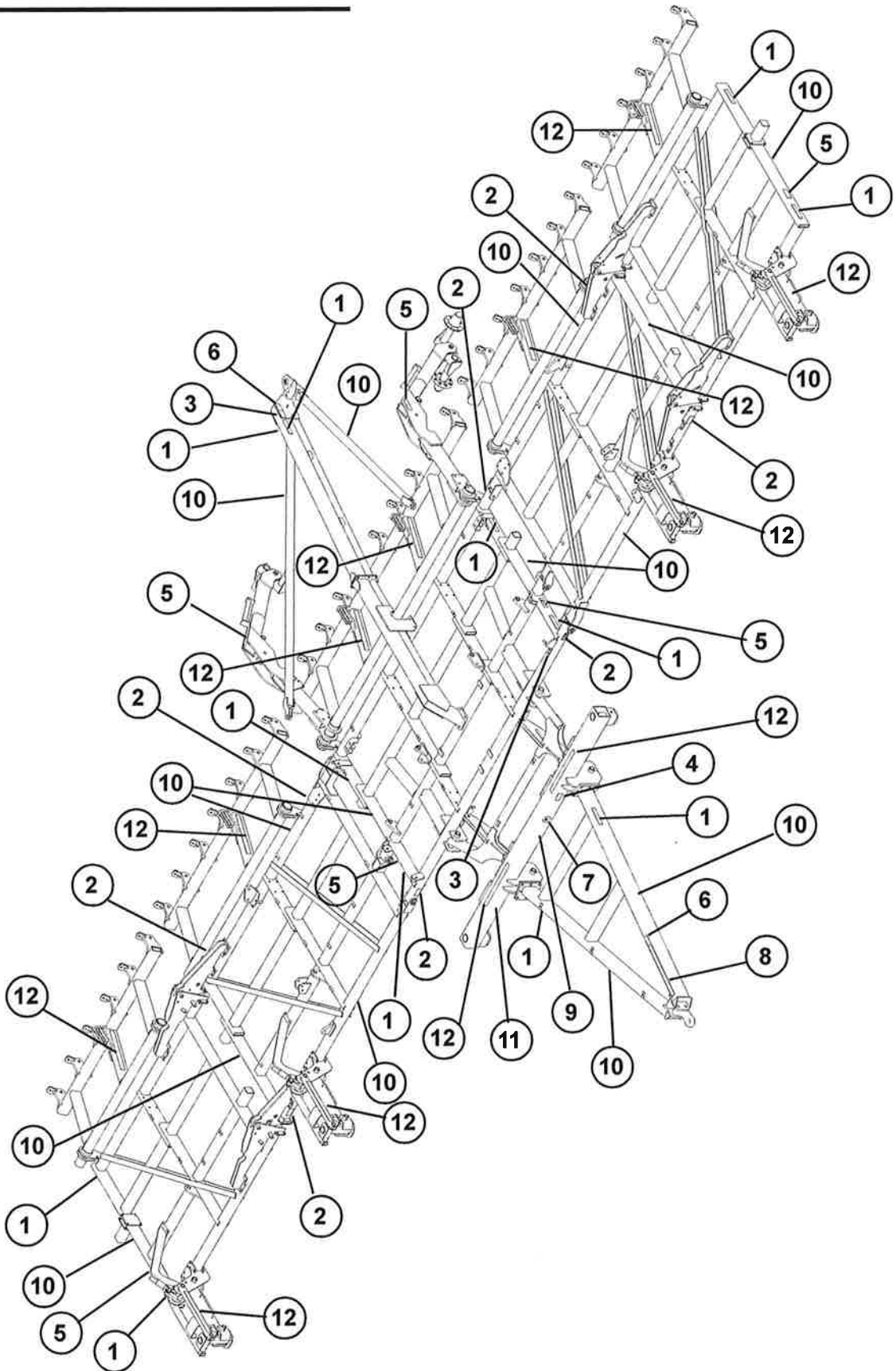



## DECAL PLACEMENT

ILLUSTRATION INDICATES LOCATION OF THE VARIOUS SAFETY RELATED DECALS WHICH ARE APPLIED BY FACTORY PERSONNEL OR WILL REQUIRE PLACEMENT BY SETUP PERSONNEL. GENERAL LOCATION OF MODEL AND BRANDING DECALS ARE NOTED AND SOME MODEL COMPONENTS HAVE BEEN REMOVED FOR CLARITY. MODEL AND BRANDING DECAL QUANTITY CAN VARY BY UNIT CONFIGURATION. BASE METAL MUST NOT BE COLD TO ENSURE PROPER DECAL ADHESION.

ITEM	PART NO.	DESCRIPTION	QTY
1	22372	AMBER REFLECTOR	12
2	997854	DECAL FOLDING WINGS DANGER	8
3	997860	DECAL READ MANUAL WARNING	1
4	997863	DECAL HIGH VOLTAGE	1
5	997864	DECAL LOCKOUT WARNING	6
6	9971010	DECAL CHEMICAL HAZARD WARNING	2
7	9971017	DECAL SPEED SIGN 15 MILE/HR	1
8	9971163	DECAL SAFETY SET	1
9	8888315-ADHESIVE	PLATE - SERIAL NO. (AGCO) ADHESIVE BACKED	1
10	VARIES BY MODEL	MODEL BRANDING DECAL	16
11	VARIES BY MODEL	MODEL NUMBER DECAL	1
12	A1030712	DECAL - DEPTH STOP	12

# SAFETY LIGHTS MOUNTING

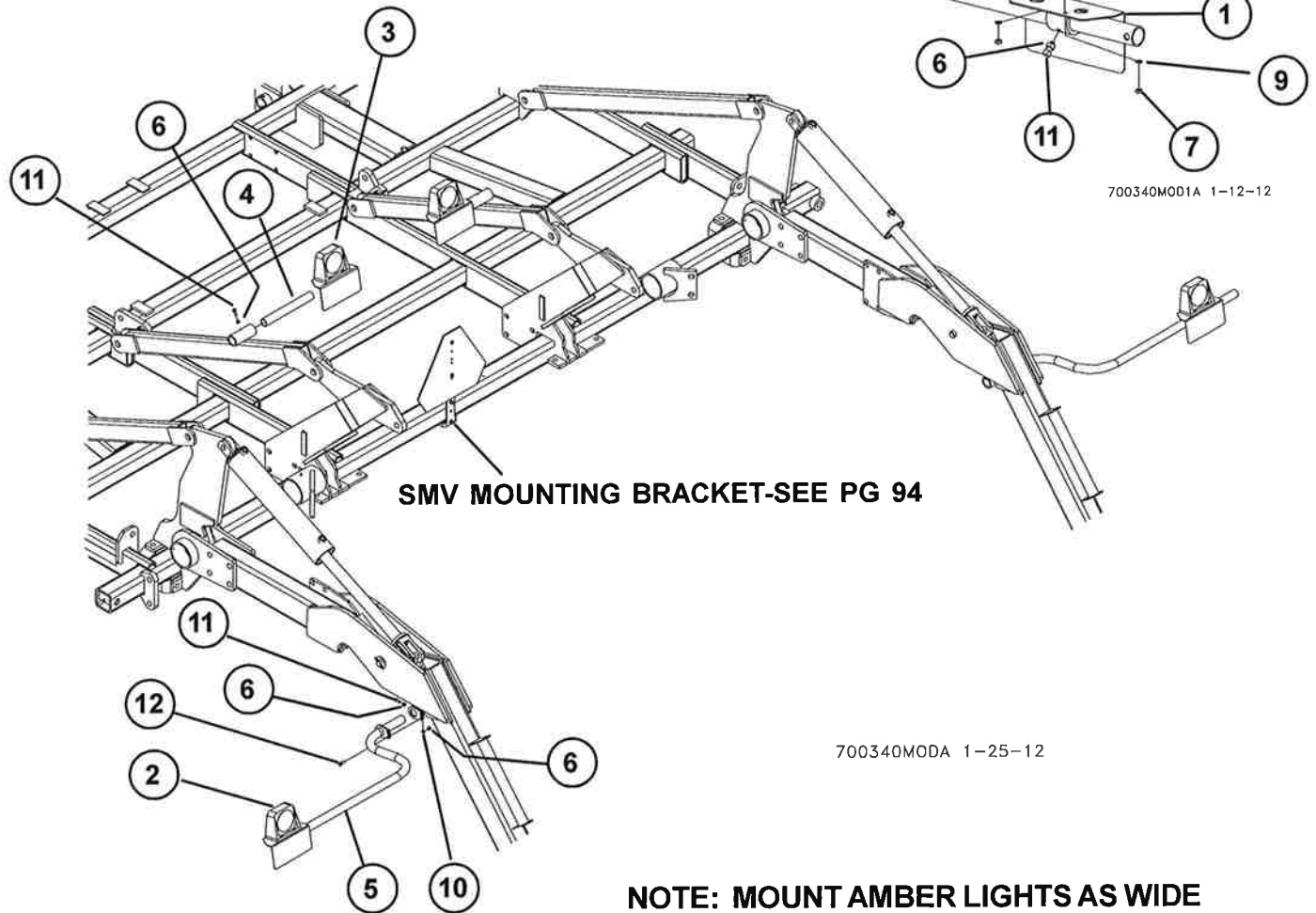

**NOTE: MOUNT AMBER LIGHTS AS WIDE AS POSSIBLE. THE AMBER LIGHTS MUST BE MOUNTED NO MORE THAN 16" FROM THE IMPLEMENT EXTREMITIES.**

ITEM	PART NO.	DESCRIPTION	QTY
1	223126	LIGHT/REFLECTOR BRACKET	4
2	A65954	LAMP-AMBER WARNING	2
3	A65953	LAMP-RED TAIL	2
4	223160	12 LIGHT ARM	2
5	240238	48IN OFFSET LIGHT ARM W/LOCK	2
6	88103	NUT HEX 3/8-16NC 5Z	12
7	88172	NUT HEX 1/4-20NC 5Z	16
8	88203	BLT HEX 1/4-20NCX1 5Z	16
9	88262	WSHR HLK 1/4ID(5/16ACT) Z	16
10	88362	WSHR HLK 3/8ID Z	2
11	88702	SCR SET 3/8NCX3/4 SQHD CUP-PT P	10
12	88555	BLT HEX 3/8NC X 1-1/4 5Z	2

# SAFETY LIGHTS WIRE ROUTING

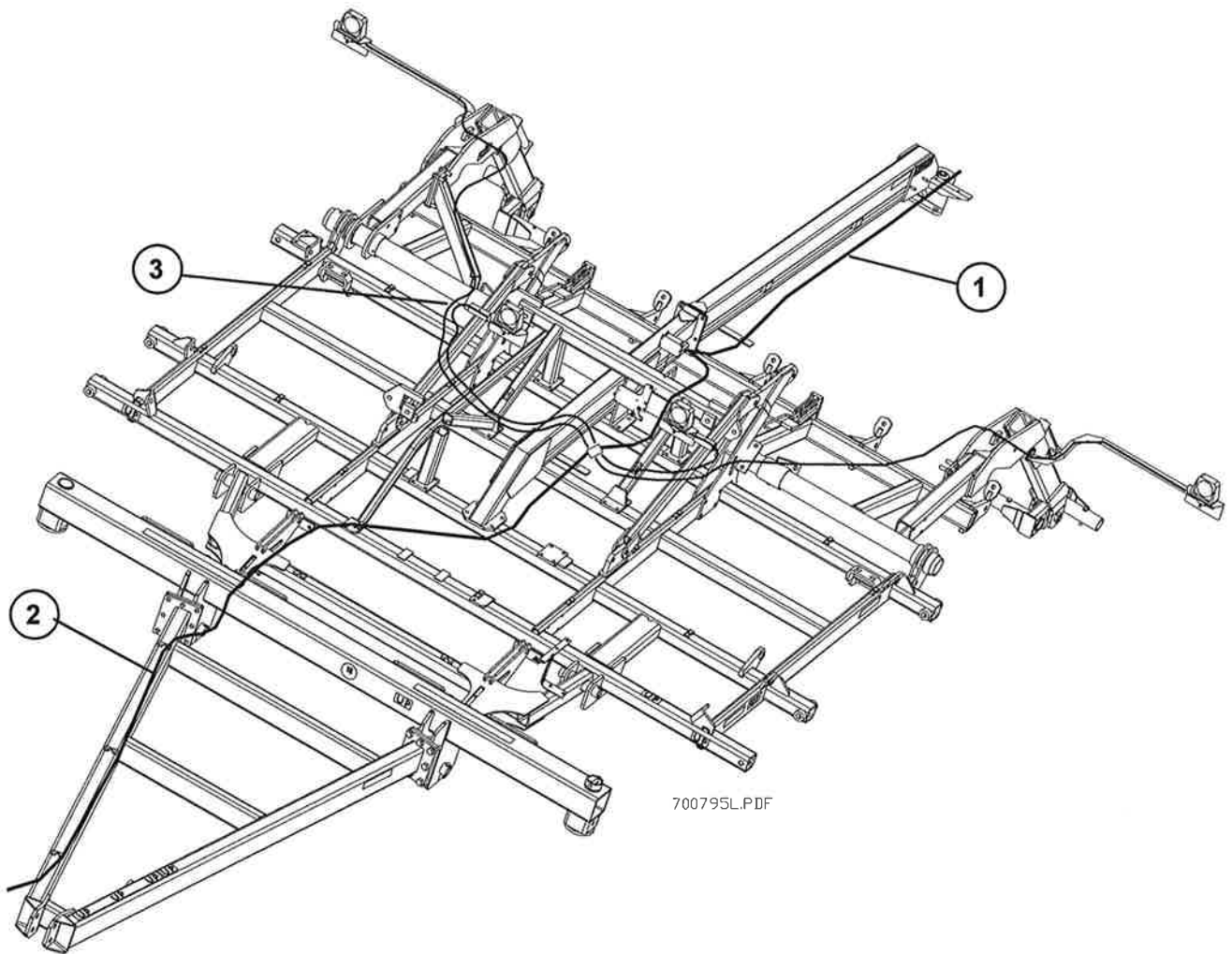

ITEM NO.	PART NO.	DESCRIPTION	QTY
1	A34567	HARNESS-EXT LIGHT 20'	1
2	A65340	HARNESS-SAFETY LIGHT S279.11	1
3	A65354	HARNESS-LIGHT EXTENSION	1

**Route wires along hydraulic lines, utilizing the hoses to carry the wires, securing with nylon ties. Coil excess wire as required and secure in place. Route the safety light wires through the various mounting tubes as shown.**

# SAFETY LIGHTS MODULE MOUNTING

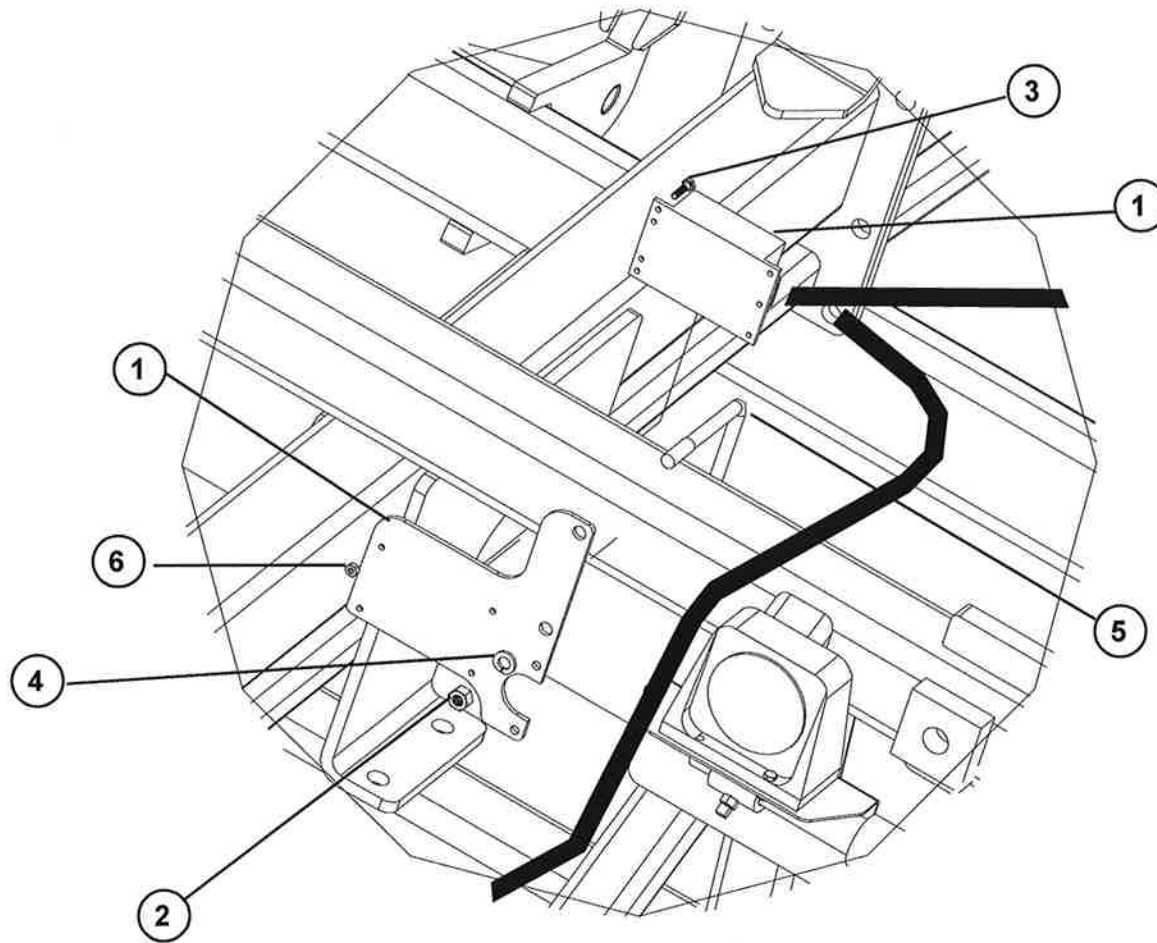

700795L1.PDF

ITEM NO.	PART NO.	DESCRIPTION	QTY
1	344112	PLATE-SAFETY LIGHT MODULE MOUNT	1
2	88104	NUT HEX 1/2-13NC 5Z	1
3	88203	BLT HEX 1/4-20NC X 1 5Z	4
4	88303	WSHR HLK 1/2ID(9/16ACT) Z	2
5	89270	BLT-U 1/2-13NC X 4 X 5-1/4 Z	1
6	89501	NUT TOP LK 1/4-20NC 5Z	4
7	A65341	MODULE-INTERFACE	1

# ISOBUS AND OPTIONAL NH3 MODULE MOUNTING

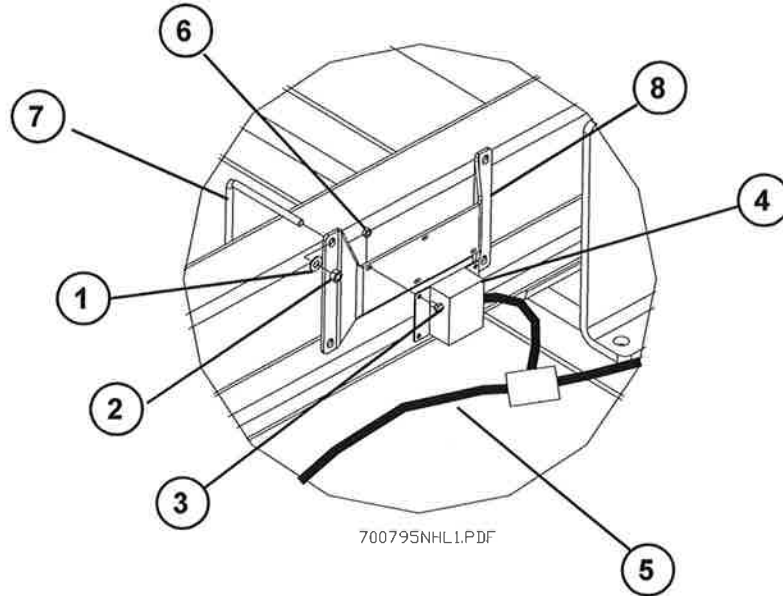

ROUTE ISOBUS HARNESS WIRE ALONG THE HYDRAULIC SUPPLY HOSES, SECURE TO CLAMPS OR WITH NYLON TIES.

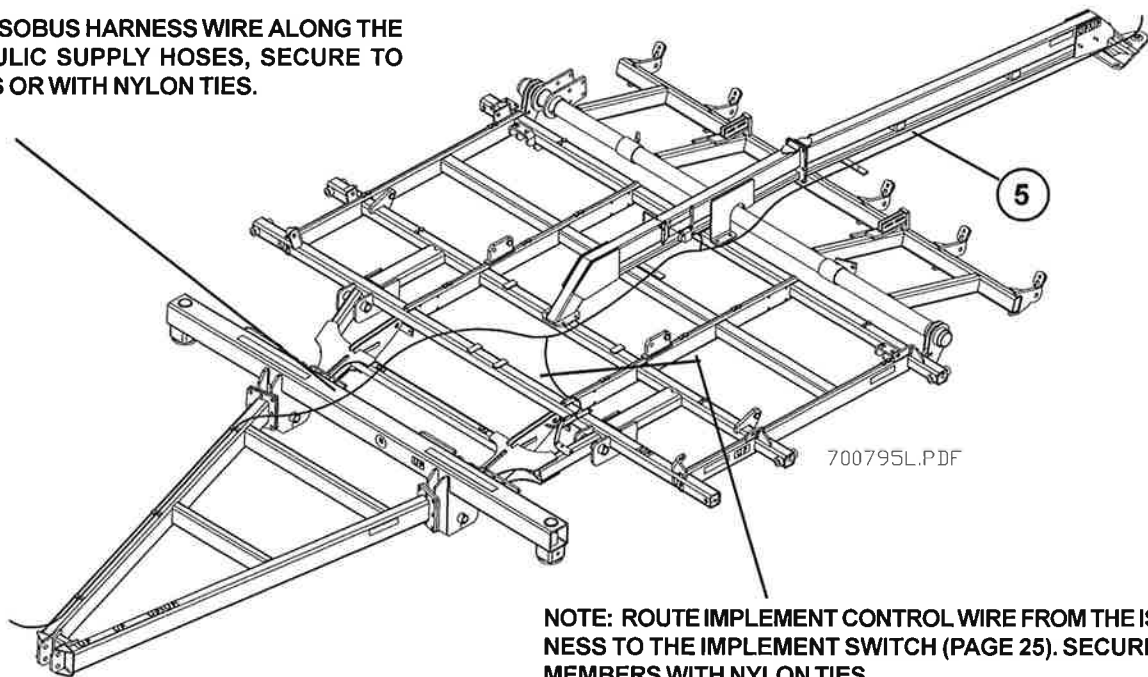

NOTE: ROUTE IMPLEMENT CONTROL WIRE FROM THE ISOBUS HARNESS TO THE IMPLEMENT SWITCH (PAGE 25). SECURE TO FRAME MEMBERS WITH NYLON TIES.

ITEM	PART NO.	DESCRIPTION	QTY
1	88282	WSHR FLAT 3/8(7/16 X 1ACT) Z	2
2	88659	NUT TOP LK 3/8-16NC 5Z	2
3	89522	SCREW-P-H: .19 X .50 NC SS	2
4	330341	MODULE-NH3 W/SW - AMD2305 V3_01	1
5	320562	HARNESS-TOOLBAR ISOBUS	1
6	1032059	NUT-K-LOCK: 18-8 SS .19 (10-24)NC	4
7	A64364	U-BOLT: .375 X 5.13 X 6 X 5.13	1
8	A67832	PLATE-MODULE MOUNT (4" & 6")	1

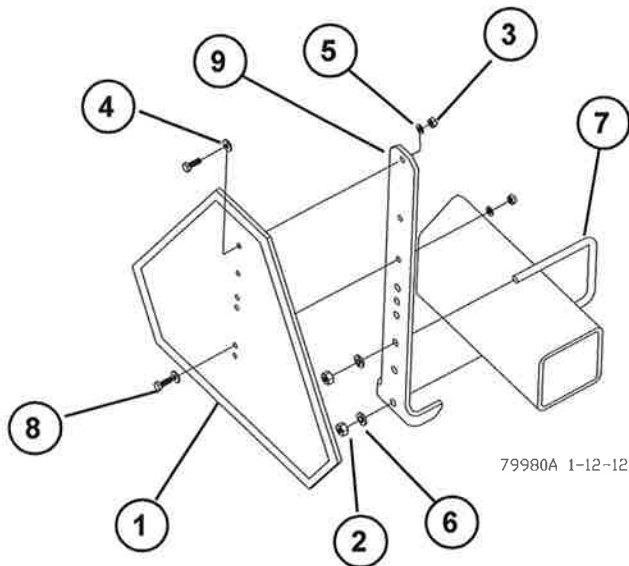

## SAFETY

The bracket provided is designed to mount to numerous frame sizes and can be orientated in numerous positions to avoid interference with implement components.

The SMV emblem is to be secured as near to the rear and centered, or as near to the left of center of the implement as possible.

Emblem is to be 2 to 6 feet above the ground measured from the ground edge of the emblem.

ITEM	PART NO	DESCRIPTION	QTY
1	30651	SMV EMBLEM S276.6	1
2	88103	NUT HEX 3/8-16NC 5Z	2
3	88172	NUT HEX 1/4-20NC 5Z	2
4	88261	WSHR FLAT 1/4(5/16 X 3/4ACT) Z	2
5	88262	WSHR HLK 1/4ID(5/16ACT) Z	2
6	88362	WSHR HLK 3/8ID Z	2
7	88385	BLT-U 3/8-16NCX4X5 Z	1
8	88203	BLT HEX 1/4-20NC X 1 5Z	2
9	350933	SMV BRACKET	1

