

REAR HITCH MOUNTING INSTRUCTIONS 2008/2009 AIR TILL DRILL

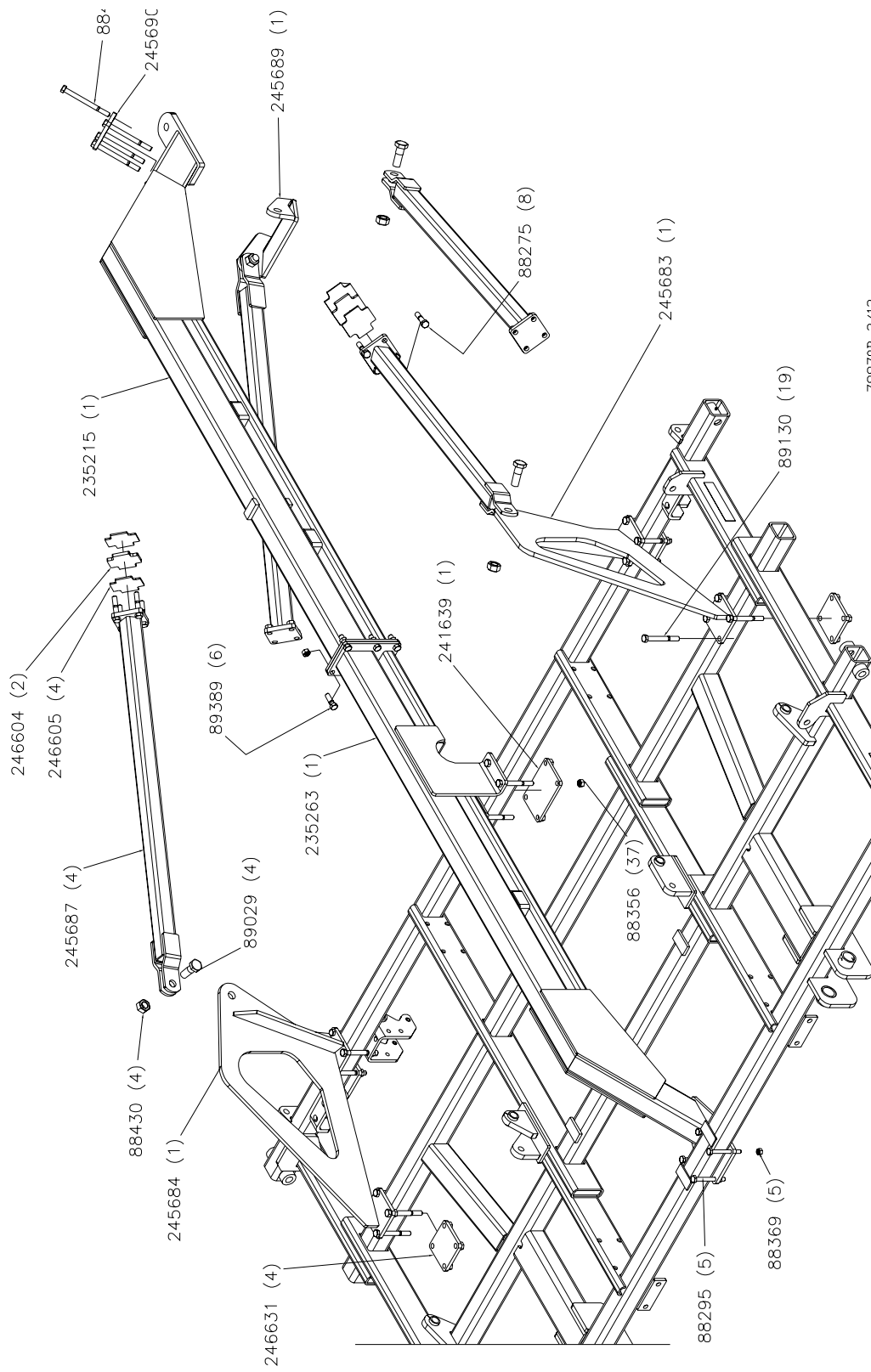

79970B 2/12

HITCH BRACE ASSY - 79970B 2/12

PART NO	DESCRIPTION	QTY
88275	BLT HEX 3/4-10NC X 4 8YZ	8
88295	BLT HEX 5/8-11NC X 6 5Z	5
88356	NUT 2POSLK 3/4-10NC 5Z	37
88369	NUT 2POSLK 5/8-11NC 5Z	5
88430	NUT 2POSLK 1-1/4-7NC 5Z	4
88487	BLT HEX 3/4-10NC X 8-1/2 5Z	4
89029	BLT HEX 1-1/4-7NC X 4 5Z	4
89130	BLT HEX 3/4-10NC X 6-1/2 5Z	19
89389	BLT HEX 3/4-10NC X 2-1/2 8YZ	6
235215	ATD HITCH - REAR	1
235263	ATD HITCH - FRONT	1
241639	REAR HITCH PLATE (RED)	1
245683	LEFT BRACE BRACKET	1
245684	RIGHT BRACE BRACKET	1
245687	REAR BRACE TUBE	4
245689	REAR ANCHOR POINT	1
245690	REAR BRACE PLATE	1
246604	BRACE SHIM - 1/2IN (ZINC)	2
246605	BRACE SHIM - 1/4IN	4
246631	PLATE	4

REAR HITCH & BRACE ASSEMBLY

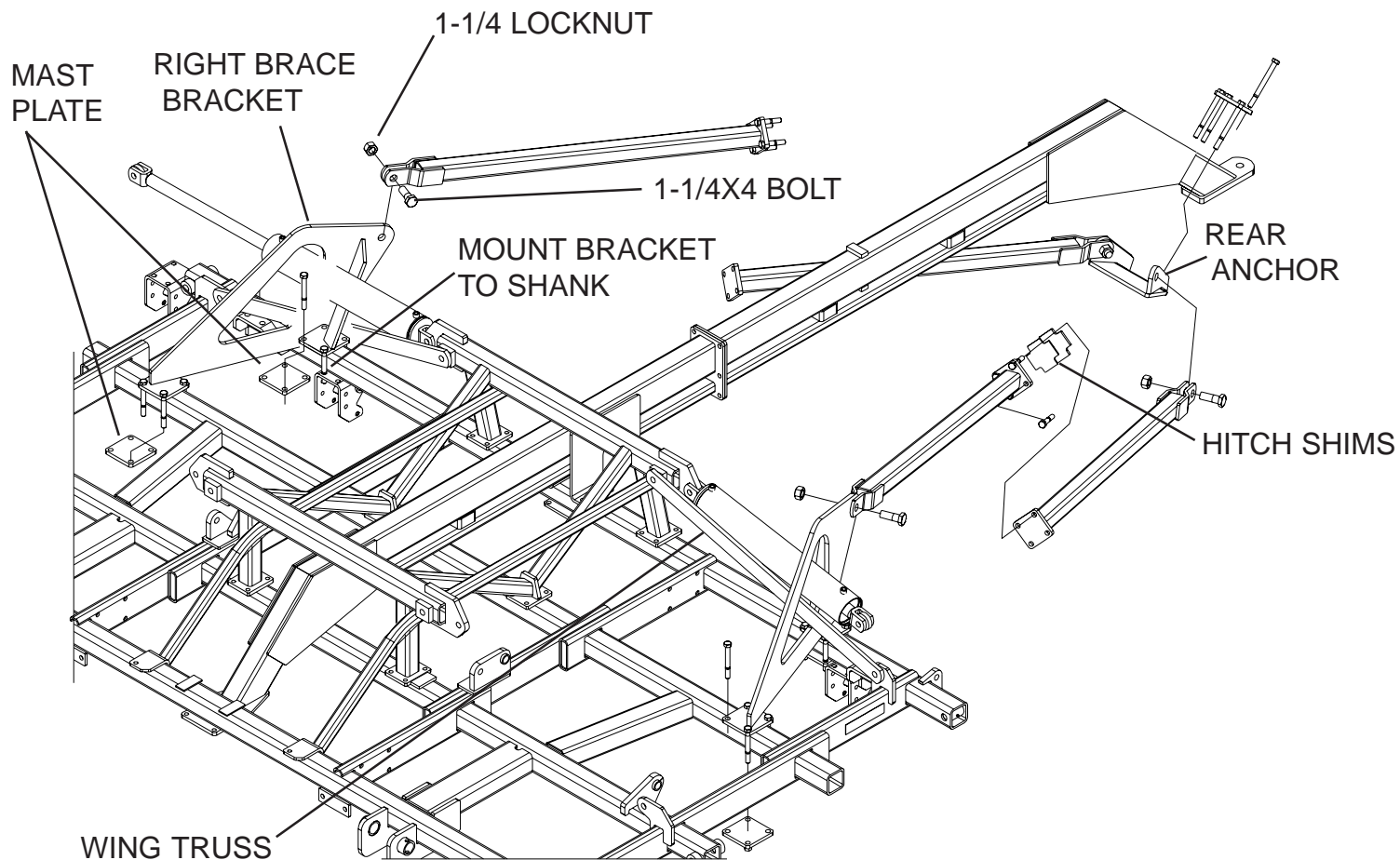

BEFORE ATTEMPTING TO ADD REAR HITCH BRACE TUBES TO THE EXISTING HITCH, LOOSEN ALL MOUNTING LOCATIONS ON THE EXISTING HITCH. PLACE THE REAR ANCHOR UNDER THE HITCH IN FRONT OF THE HITCH POINT AS SHOWN, SLIDE UP UNTIL ANCHOR CONTACTS HITCH SIDE GUSSETS. LEFT AND RIGHT BRACE BRACKETS REQUIRE THAT THE WING FOLD CYLINDERS AND TRUSS STRAPS BE REMOVED TO POSITION BRACE BRACKET APPROXIMATELY WHERE SHOWN. LOOSELY SECURE THE BRACE BRACKETS WITH THE PLATES AND BOLTS AS SHOWN. ATTACH THE REAR BRACE TUBES TO THE BRACE BRACKETS AND REAR ANCHOR WITH THE 1-1/4 IN BOLTS. ALIGN THE PLATED ENDS OF THE BRACE TUBES, INSERT THE 3/4 X 4 BOLTS TO LOOSELY SECURE THE JOINT. USE THE VARYING THICKNESS HITCH SHIMS TO PROVIDE THE CORRECT LENGTH OF THE BRACE TUBE ASSEMBLY. THE RIGHT HAND BRACE BRACKET WILL BE SECURED BY USING THE OUTER HOLES OF THE SHANK AND THE INNER HOLES OF THE MAST PLATES. UTILIZE THE SHANK MOUNTING HARDWARE AT THAT POINT TO SECURE. ONCE ALL BOLTED CONNECTIONS HAVE BEEN MADE, CENTER THE HITCH ON THE UNIT AND TIGHTEN ALL HARDWARE.